

# MACHOS

# TERRAJAS

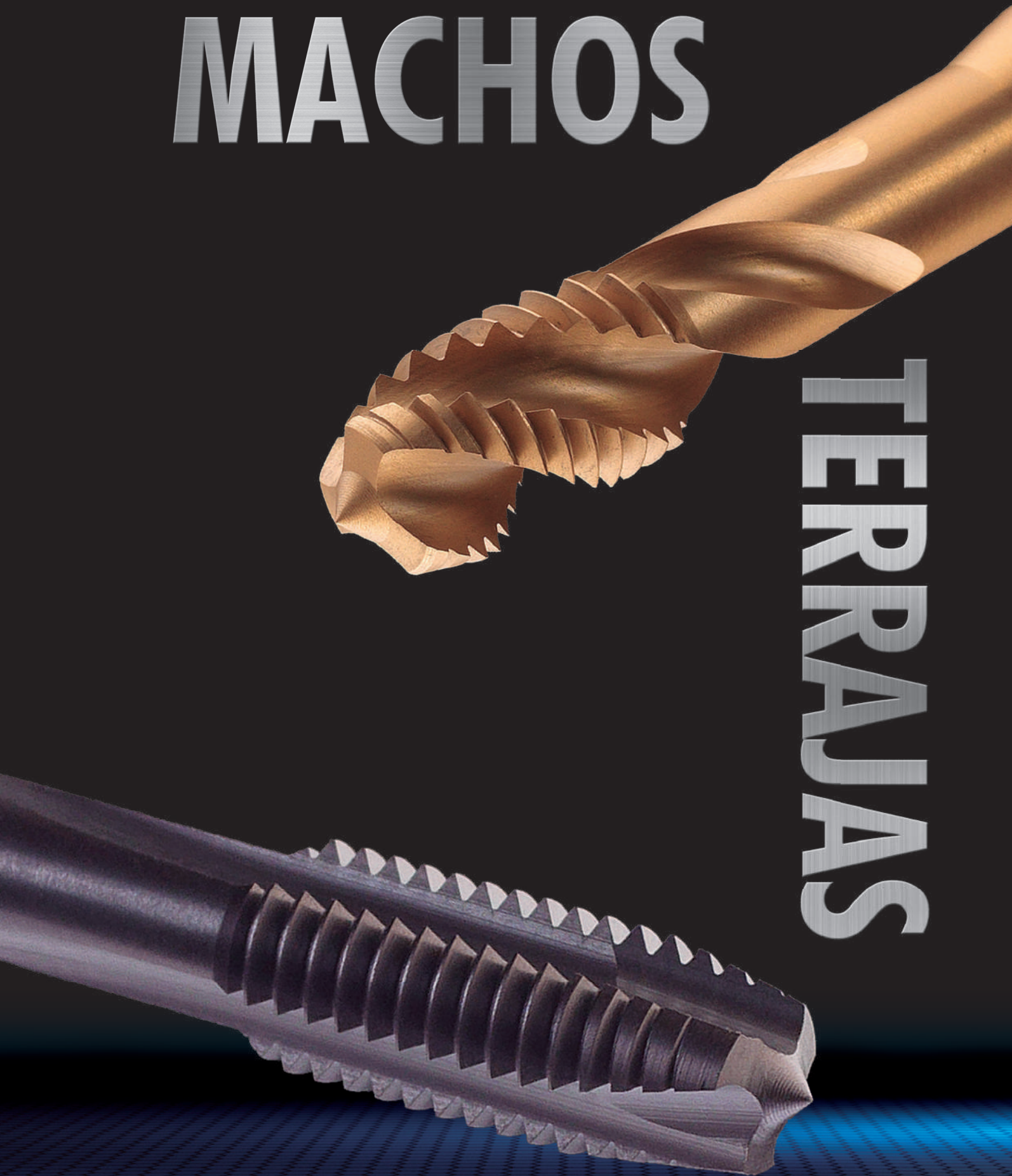

**JUEGOS DE MACHOS Y TERRAJAS PARA ROSCAR A MANO HSS**

Machos y Terrajas

Verde

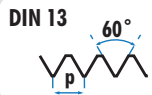

Ref. M0

HSS

DIN 352

DIN 2181

TOL 6H

Ref. C5

HSS

DIN 223

TOL 6g

Para materiales hasta 38 HRC







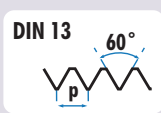

		M0				C5				M0		C5	
	Uds.		L1 x L2 x $\nabla$ mm	€	Ø x L3 mm	€		Uds.		L1 x L2 x $\nabla$ mm	€	Ø x L3 mm	€
M 1x0,20	2	0,80	32 x 5,5 x 2,1	79,25			M 5,5x0,90	3	4,60	50 x 16 x 4,9	80,42	25 x 9	90,56
<b>M 1x0,25</b>	<b>3</b>	<b>0,75</b>	32 x 6,0 x 2,1	79,25	16 x 5	84,74	M 6x0,50	2	5,50	50 x 14 x 4,9	27,30	20 x 5	35,04
M 1,1x0,20	2	0,90	32 x 5,5 x 2,1	79,25			M 6x0,75	2	5,25	50 x 14 x 4,9	23,05	25 x 9	28,74
M 1,1x0,25	3	0,85	32 x 6,0 x 2,1	79,25	16 x 5	83,81	<b>M 6x1,00</b>	<b>3</b>	<b>5,00</b>	50 x 19 x 4,9	20,42*	25 x 9	25,57*
M 1,2x0,20	2	1,00	32 x 5,5 x 2,1	79,25			M 6x1,25	3	4,75	50 x 19 x 4,9	131,93	25 x 9	92,73
M 1,2x0,25	3	0,95	32 x 6,0 x 2,1	79,25	16 x 5	78,65	M 7x0,75	2	6,25	50 x 14 x 4,9	29,44	25 x 9	28,45
M 1,4x0,20	2	1,20	32 x 7,0 x 2,1	79,25			<b>M 7x1,00</b>	<b>3</b>	<b>6,00</b>	50 x 19 x 4,9	24,86*	25 x 9	27,59*
M 1,4x0,25	2	1,15	32 x 7,0 x 2,1	79,25			M 7x1,25	3	5,75	50 x 19 x 4,9	91,67	25 x 9	111,44
M 1,4x0,30	3	1,10	32 x 7,0 x 2,1	79,25	16 x 5	72,07	M 8x0,50	2	7,50	50 x 16 x 4,9	46,87	25 x 9	42,47
M 1,6x0,20	2	1,40	32 x 8,0 x 2,1	72,31			M 8x0,75	2	7,25	50 x 16 x 4,9	31,71	25 x 9	30,77
M 1,6x0,25	2	1,35	32 x 8,0 x 2,1	72,31			M 8x1,00	2	7,00	56 x 18 x 4,9	22,93*	25 x 9	29,66*
M 1,6x0,35	3	1,25	32 x 8,0 x 2,1	72,31	16 x 5	68,09	<b>M 8x1,25</b>	<b>3</b>	<b>6,80</b>	56 x 22 x 4,9	24,84*	25 x 9	27,13*
M 1,7x0,35	3	1,35	32 x 8,0 x 2,1	67,87	16 x 5	68,09	M 8x1,50	3	6,50	56 x 22 x 4,9	89,16	25 x 9	96,88
M 1,8x0,20	2	1,60	32 x 8,0 x 2,1	67,87			M 9x1,00	2	8,00	63 x 18 x 5,5	32,69	25 x 9	32,96
M 1,8x0,25	2	1,55	32 x 8,0 x 2,1	67,87			<b>M 9x1,25</b>	<b>3</b>	<b>7,80</b>	63 x 22 x 5,5	40,70*	25 x 9	31,53*
M 1,8x0,35	3	1,45	32 x 8,0 x 2,1	67,87	16 x 5	68,09	M 10x0,50	2	9,50	63 x 18 x 5,5	49,67	30 x 10	107,06
M 2x0,25	2	1,75	36 x 8,0 x 2,1	67,87			M 10x0,75	2	9,25	63 x 18 x 5,5	49,42	30 x 11	52,64
M 2x0,35	2	1,65	36 x 8,0 x 2,1	67,87			M 10x1,00	2	9,00	63 x 18 x 5,5	24,56	38 x 10	34,90
<b>M 2x0,40</b>	<b>3</b>	<b>1,60</b>	36 x 9,0 x 2,1	34,04*	16 x 5	28,11*	M 10x1,25	2	8,80	70 x 24 x 5,5	24,90	38 x 10	37,23
M 2,2x0,45	3	1,75	36 x 9,0 x 2,1	38,65	20 x 5	60,11	<b>M 10x1,50</b>	<b>3</b>	<b>8,50</b>	70 x 24 x 5,5	30,63*	38 x 10	36,31*
M 2,3x0,40	3	1,90	36 x 9,0 x 2,1	35,67	20 x 5	30,83	M 11x0,75	2	10,25	63 x 18 x 6,2	74,56	30 x 11	115,66
M 2,5x0,45	3	2,05	40 x 9,0 x 2,1	33,91	20 x 5	28,11	M 11x1,00	2	10,00	63 x 18 x 6,2	46,98	30 x 11	55,08
M 2,6x0,45	3	2,10	40 x 9,0 x 2,1	34,67	25 x 9	29,43	M 11x1,25	2	9,75	63 x 20 x 6,2	46,98	30 x 11	55,07
M 3x0,35	2	2,65	40 x 9,0 x 2,7	44,32	20 x 5	44,51	<b>M 11x1,50</b>	<b>3</b>	<b>9,50</b>	70 x 24 x 6,2	51,05	38 x 10	43,99
<b>M 3x0,50</b>	<b>3</b>	<b>2,50</b>	40 x 11,0 x 2,7	19,11*	25 x 9	25,57*	M 12x0,75	2	11,25	70 x 20 x 7,0	67,80	38 x 10	59,71
M 3x0,60	3	2,40	45 x 13,0 x 3,0	38,86	20 x 5	34,88	M 12x1,00	2	11,00	70 x 20 x 7,0	43,55	38 x 10	52,64
M 3,5x0,60	3	2,90	45 x 13,0 x 3,0	22,79	25 x 9	26,75	M 12x1,25	2	10,75	70 x 20 x 7,0	43,42	38 x 10	50,74
M 3,5x0,75	3	2,75	45 x 18,0 x 3,0	42,20	25 x 9	60,15	M 12x1,50	2	10,50	70 x 20 x 7,0	37,00*	38 x 10	45,51*
M 4x0,50	2	3,50	45 x 13,0 x 3,4	38,33	25 x 9	28,73	<b>M 12x1,75</b>	<b>3</b>	<b>10,20</b>	75 x 29 x 7,0	43,11*	38 x 14	39,45*
<b>M 4x0,70</b>	<b>3</b>	<b>3,30</b>	45 x 13,0 x 3,4	19,09*	25 x 9	25,69*	M 13x0,75	2	12,25	70 x 20 x 9,0	74,56	38 x 10	105,29
M 4x0,75	3	3,25	45 x 13,0 x 3,4	31,61	20 x 7	38,86	M 13x1,00	2	12,00	70 x 20 x 9,0	71,78	38 x 10	55,92
M 4x0,80	3	3,20	45 x 13,0 x 3,4	76,16	20 x 7	91,86	M 13x1,25	2	11,75	70 x 20 x 9,0	67,34	38 x 10	74,77
M 4,5x0,50	2	4,00	50 x 12,0 x 4,9	37,17	25 x 9	40,01	M 13x1,50	2	11,50	70 x 20 x 9,0	67,34	38 x 10	58,78
M 4,5x0,75	3	3,75	50 x 16,0 x 4,9	34,04	20 x 7	28,12	<b>M 13x1,75</b>	<b>3</b>	<b>11,25</b>	70 x 20 x 9,0	77,91	38 x 14	62,98
M 5x0,50	2	4,50	50 x 12,0 x 4,9	38,15	20 x 5	31,36	M 14x0,75	2	13,25	70 x 20 x 9,0	85,69	38 x 10	98,72
M 5x0,75	2	4,25	50 x 14,0 x 4,9	37,87	20 x 7	39,06	M 14x1,00	2	13,00	70 x 20 x 9,0	66,07	38 x 10	57,44
<b>M 5x0,80</b>	<b>3</b>	<b>4,20</b>	50 x 16,0 x 4,9	20,42*	25 x 9	25,55*	M 14x1,25	2	12,80	70 x 20 x 9,0	53,01*	38 x 10	57,44*
M 5x0,90	3	4,10	50 x 16,0 x 4,9	36,09	25 x 9	39,06	M 14x1,50	2	12,50	70 x 20 x 9,0	41,23	38 x 10	48,90
M 5x1,00	3	4,00	50 x 16,0 x 4,9	80,42	25 x 9	88,57	M 14x1,75	2	12,25	70 x 20 x 9,0	82,46	38 x 14	168,12
							<b>M 14x2,00</b>	<b>3</b>	<b>12,00</b>	80 x 30 x 9,0	47,69*	38 x 14	39,07*
							M 15x1,00	2	14,00	70 x 20 x 9,0	95,10	45 x 14	63,56
							M 15x1,25	2	13,75	70 x 20 x 9,0	98,54	45 x 14	98,47
							M 15x1,50	2	13,50	70 x 20 x 9,0	88,22	45 x 14	68,10
							<b>M 15x2,00</b>	<b>3</b>	<b>13,00</b>	80 x 30 x 9,0	95,32	45 x 14	85,35
							M 16x1,00	2	15,00	70 x 20 x 9,0	90,05	45 x 14	71,96
							M 16x1,25	2	14,75	70 x 20 x 9,0	94,78	45 x 14	60,55
							M 16x1,50	2	14,50	70 x 20 x 9,0	51,30*	45 x 14	55,01*
							<b>M 16x2,00</b>	<b>3</b>	<b>14,00</b>	80 x 32 x 9,0	67,66*	45 x 18	52,96*
							M 17x1,00	2	16,00	70 x 20 x 9,0	145,44	45 x 14	102,98
							M 17x1,25	2	15,75	70 x 20 x 9,0	145,44	45 x 14	102,98
							M 17x1,50	2	15,50	70 x 20 x 9,0	145,44	45 x 14	102,98
							M 18x1,00	2	17,00	80 x 22 x 11,0	100,11	45 x 14	76,09
							M 18x1,25	2	16,75	80 x 22 x 11,0	139,08	45 x 14	79,14

\* Disponibles también con rosca izquierda con 100% de recargo sobre los precios tarifados en rosca derecha  
 \* Recargo por cojinetes abiertos 20% sobre los precios tarifados



**JUEGOS DE MACHOS Y TERRAJAS PARA ROSCAR A MANO HSS**

**M MF**  Ref. M0 **HSS** **DIN 352** **DIN 2181** **TOL 6H** Ref. C5 **HSS** **DIN 223** **TOL 6g**

M0						C5						M0						C5					
	Uds.		L1 x L2 x $\nabla$ mm	€	Ø x L3 mm	€		Uds.		L1 x L2 x $\nabla$ mm	€	Ø x L3 mm	€		Uds.		L1 x L2 x $\nabla$ mm	€	Ø x L3 mm	€			
M 18x1,50	2	16,50	80 x 22 x 11,0	67,60	45 x 14	66,62	M 33x3,50	3	29,5	125 x 50 x 20,0	327,78*	65 x 25	121,47*										
M 18x2,00	2	16,00	80 x 22 x 11,0	107,89*	45 x 14	74,44*	M 34x1,50	2	32,5	100 x 25 x 22,0	327,80	65 x 18	139,02										
<b>M 18x2,50</b>	<b>3</b>	<b>15,50</b>	95 x 40 x 11,0	<b>89,29*</b>	45 x 18	<b>52,98*</b>	M 34x2,00	2	32,0	100 x 25 x 22,0	402,83	65 x 18	317,32										
M 19x1,00	2	18,00	80 x 22 x 11,0	211,06	45 x 14	163,80	M 35x1,50	2	33,5	100 x 25 x 22,0	359,61	65 x 18	144,19										
M 19x1,25	2	17,75	80 x 22 x 11,0	211,06	45 x 14	185,25	M 35x2,00	2	33,0	100 x 25 x 22,0	402,83	65 x 18	317,32										
M 19x1,50	2	17,50	80 x 22 x 11,0	211,06	45 x 14	163,80	M 36x1,50	2	34,5	100 x 25 x 22,0	351,10	65 x 18	136,50										
M 19x2,00	2	17,00	80 x 22 x 11,0	250,55	45 x 14	187,13	M 36x2,00	2	34,0	125 x 33 x 22,0	450,05	65 x 18	142,37										
M 20x1,00	2	19,00	80 x 22 x 12,0	132,65	45 x 14	76,09	M 36x3,00	2	33,0	125 x 33 x 22,0	594,41*	65 x 25	142,84*										
M 20x1,25	2	18,75	80 x 22 x 12,0	210,29	45 x 14	165,15	<b>M 36x4,00</b>	<b>3</b>	<b>32,0</b>	150 x 53 x 22,0	418,16*	65 x 25	123,84*										
M 20x1,50	2	18,50	80 x 22 x 12,0	84,65	45 x 14	70,04	M 38x1,50	2	36,5	100 x 25 x 22,0	394,93	75 x 20	208,56										
M 20x2,00	2	18,00	80 x 22 x 12,0	111,23*	45 x 14	76,09*	M 38x2,00	2	36,0	125 x 25 x 22,0	541,20	75 x 20	395,19										
<b>M 20x2,50</b>	<b>3</b>	<b>17,50</b>	95 x 40 x 12,0	<b>100,17*</b>	45 x 18	<b>53,63*</b>	M 39x1,50	2	37,5	110 x 25 x 24,0	522,71	75 x 20	207,45										
M 21x1,00	2	20,00	80 x 22 x 12,0	270,42	45 x 14	200,68	M 39x2,00	2	37,0	125 x 23 x 24,0	522,71	75 x 20	219,07										
M 21x1,25	2	19,75	80 x 22 x 12,0	270,42	45 x 14	200,68	M 39x3,00	2	36,0	125 x 33 x 24,0	504,21*	75 x 30	223,76*										
M 21x1,50	2	19,50	80 x 22 x 12,0	210,50	45 x 14	165,42	<b>M 39x4,00</b>	<b>3</b>	<b>35,0</b>	150 x 53 x 24,0	472,35*	75 x 30	188,36*										
M 22x1,00	2	21,00	80 x 22 x 14,5	148,65	55 x 16	102,43	M 40x1,50	2	38,5	110 x 25 x 24,0	463,77	75 x 20	217,92										
M 22x1,25	2	20,75	80 x 22 x 14,5	208,27	55 x 16	166,93	M 40x2,00	2	38,0	125 x 33 x 24,0	520,00	75 x 20	202,36										
M 22x1,50	2	20,50	80 x 22 x 14,5	93,10	55 x 16	88,12	M 40x3,00	2	37,0	125 x 33 x 24,0	518,10	75 x 30	220,69										
M 22x2,00	2	20,00	80 x 22 x 14,5	148,51*	55 x 16	98,05*	M 42x1,50	2	40,5	110 x 25 x 24,0	513,28	75 x 20	242,30										
<b>M 22x2,50</b>	<b>3</b>	<b>19,50</b>	100 x 40 x 14,5	<b>134,52*</b>	55 x 22	<b>78,36*</b>	M 42x2,00	2	40,0	125 x 33 x 24,0	597,60	75 x 20	328,55										
M 23x1,00	2	22,00	80 x 22 x 14,5	272,77	55 x 16	217,06	M 42x3,00	2	39,0	125 x 33 x 24,0	600,17	75 x 30	242,30										
M 23x1,50	2	21,50	80 x 22 x 14,5	271,71	55 x 16	200,68	<b>M 42x4,50</b>	<b>3</b>	<b>37,5</b>	150 x 53 x 24,0	585,43	75 x 30	188,34										
M 24x1,00	2	23,00	90 x 22 x 14,5	164,81	55 x 16	99,91	M 45x1,50	2	43,5	110 x 25 x 29,0	560,65	90 x 22	283,13										
M 24x1,25	2	22,75	90 x 22 x 14,5	269,36	55 x 16	170,10	M 45x2,00	2	43,0	125 x 33 x 29,0	717,68	90 x 22	307,37										
M 24x1,50	2	22,50	90 x 22 x 14,5	118,69	55 x 16	89,78	M 45x3,00	2	42,0	125 x 33 x 29,0	717,68	90 x 36	320,70										
M 24x2,00	2	22,00	90 x 22 x 14,5	172,35*	55 x 16	99,91*	<b>M 45x4,50</b>	<b>3</b>	<b>40,5</b>	160 x 60 x 29,0	675,83	90 x 36	291,84										
<b>M 24x3,00</b>	<b>3</b>	<b>21,00</b>	110 x 50 x 14,5	<b>159,15*</b>	55 x 22	<b>78,36*</b>	M 48x1,50	2	46,5	140 x 33 x 29,0	625,93	90 x 22	276,68										
M 25x1,00	2	24,00	90 x 22 x 14,5	232,49	55 x 16	151,61	M 48x2,00	2	46,0	140 x 33 x 29,0	937,95	90 x 22	303,05										
M 25x1,25	2	23,75	90 x 22 x 14,5	296,34	55 x 16	256,00	M 48x3,00	2	45,0	140 x 33 x 29,0	869,68	90 x 36	292,36										
M 25x1,50	2	23,50	90 x 22 x 14,5	213,48	55 x 16	130,42	<b>M 48x5,00</b>	<b>3</b>	<b>43,0</b>	180 x 65 x 29,0	813,71	90 x 36	292,19										
M 25x2,00	2	23,00	90 x 22 x 14,5	396,52	55 x 16	248,90	M 50x1,50	2	48,5	140 x 33 x 29,0	684,53	90 x 22	288,49										
M 26x1,00	2	25,00	90 x 22 x 14,5	207,84	55 x 16	192,71	M 50x3,00	2	57,0	140 x 33 x 29,0	922,53	90 x 22	314,42										
M 26x1,50	2	24,50	90 x 22 x 14,5	195,00	55 x 16	121,16	M 52x1,50	2	50,5	140 x 33 x 32,0	724,63	90 x 22	294,60										
M 26x2,00	2	24,00	90 x 22 x 14,5	228,80	55 x 16	217,77	M 52x2,00	2	50,0	140 x 33 x 32,0	1.051,37	90 x 22	342,36										
M 27x1,00	2	26,00	90 x 22 x 16,0	228,82	65 x 18	135,18	M 52x3,00	2	49,0	140 x 33 x 32,0	967,97	90 x 36	373,61										
M 27x1,50	2	25,50	90 x 22 x 16,0	215,01	65 x 18	135,76	<b>M 52x5,00</b>	<b>3</b>	<b>47,0</b>	180 x 65 x 32,0	983,52	90 x 36	292,19										
M 27x2,00	2	25,00	90 x 22 x 16,0	238,85*	65 x 18	147,65*	<b>M 56x4,00</b>	<b>2</b>	<b>52,0</b>	180 x 47 x 32,0	1.079,36	105 x 36											
<b>M 27x3,00</b>	<b>3</b>	<b>24,00</b>	110 x 50 x 16,0	<b>202,89*</b>	65 x 25	<b>118,88*</b>	M 56x5,50	3	50,5	200 x 85 x 35,0	1.526,53	105 x 36											
M 28x1,00	2	27,00	90 x 22 x 16,0	386,18	65 x 18	224,08	<b>M 60x5,50</b>	<b>3</b>	<b>54,5</b>	200 x 85 x 35,0	1.543,88	105 x 36											
M 28x1,50	2	26,50	90 x 22 x 16,0	216,62	65 x 18	123,07	M 64x4,00	2	60,0	180 x 50 x 35,0	1.520,11	120 x 36											
M 28x2,00	2	26,00	90 x 22 x 16,0	259,18	65 x 18	221,90	<b>M 64x6,00</b>	<b>3</b>	<b>58,0</b>	220 x 90 x 39,0	1.877,08	120 x 36											
M 30x1,00	2	29,00	90 x 22 x 18,0	240,56	65 x 18	143,26	<b>M 68x6,00</b>	<b>3</b>	<b>62,0</b>	220 x 90 x 39,0	2.247,22	120 x 36											
M 30x1,50	2	28,50	90 x 22 x 18,0	224,67	65 x 18	135,75	<b>M 72x6,00</b>	<b>3</b>	<b>66,0</b>	235 x 90 x 39,0	2.434,62	120 x 36											
M 30x2,00	2	28,00	90 x 22 x 18,0	259,01	65 x 18	150,45																	
M 30x3,00	2	27,00	125 x 56 x 18,0	260,18*	65 x 25	214,90*																	
<b>M 30x3,50</b>	<b>3</b>	<b>26,50</b>	125 x 50 x 18,0	<b>261,12*</b>	65 x 25	<b>119,19*</b>																	
M 32x1,00	2	31,00	90 x 22 x 18,0	317,22	65 x 18	237,28																	
M 32x1,50	2	30,50	90 x 22 x 18,0	267,51	65 x 18	140,80																	
M 32x2,00	2	30,00	90 x 22 x 18,0	393,45	65 x 18	219,91																	
M 33x1,00	2	32,00	100 x 25 x 20,0	506,25	65 x 18	251,24																	
M 33x1,50	2	31,50	100 x 25 x 20,0	286,10	65 x 18	133,23																	
M 33x2,00	2	31,00	100 x 25 x 20,0	361,22	65 x 18	134,14																	
M 33x3,00	2	30,00	125 x 56 x 20,0	468,34*	65 x 25	265,46*																	

COJINETES CON MEDIDA EXTERIOR EN PULGADAS					
					C5
		Ø x L3 mm	€		Ø x L3 mm
M 3x0,50	25,4 x 9	22,54	M 8x1,25	38,1 x 9	23,92
M 4x0,70	25,4 x 9	22,54	M10x1,50	25,4 x 9	30,27
M 5x0,80	25,4 x 9	22,96	M10x1,50	38,1 x 10	30,27
M 6x1,00	25,4 x 9	22,54	M12x1,75	25,4 x 9	36,48
M 8x1,25	25,4 x 9	23,92	M12x1,75	38,1 x 14	36,48

\* Disponibles también con rosca izquierda con 100% de recargo sobre los precios tarifados en rosca derecha  
\* Recargo por cojinetes abiertos 20% sobre los precios tarifados

## JUEGOS DE MACHOS Y TERRAJAS PARA ROSCAR A MANO HSS

UNC

Ref. M0

HSS

DIN  
351TOL  
2B

Ref. C5

HSS

DIN  
223TOL  
2a

UNF

Ref. M0

HSS

DIN  
2181TOL  
2B

Ref. C5

HSS

DIN  
223TOL  
2a

UNC	Uds.	D1 mm	L1 x L2 x mm	M0		C5	
				€	Ø x L3 mm	€	
UNC n°1-64h.	3	1,85	1,50	36x8x2,1	93,02	16x5	
UNC n°2-56h.	3	2,18	1,80	36x9x2,1	65,73	16x5	
UNC n°3-48h.	3	2,51	2,10	40x9x2,1	65,73	16x5	
UNC n°4-40h.	3	2,84	2,25	40x11x2,7	49,78	20x5	36,94
UNC n°5-40h.	3	3,17	2,60	40x11x2,7	47,59	20x5	37,03
UNC n°6-32h.	3	3,50	2,75	45x13x3,0	47,59	20x7	37,03
UNC n°8-32h.	3	4,17	3,50	45x13x3,4	47,59	20x7	37,03
UNC n°10-24h.	3	4,83	3,90	50x16x4,9	47,59	20x7	37,03
UNC n°12-24h.	3	5,49	4,50	50x19x4,9	47,59	20x7	37,03
UNC 1/4-20h.	3	6,35	5,10	50x19x4,9	40,78*	20x7	34,90*
UNC 5/16-18h.	3	7,94	6,60	56x22x4,9	46,31*	25x9	35,82*
UNC 3/8-16h.	3	9,52	8,00	70x24x5,5	52,68*	30x11	49,79*
UNC 7/16-14h.	3	11,11	9,40	70x24x6,2	68,60	38x14	49,79
UNC 1/2-13h.	3	12,70	10,75	75x29x7,0	78,93*	38x14	51,19*
UNC 9/16-12h.	3	14,28	12,20	80x30x9,0	93,18	38x14	53,57
UNC 5/8-11h.	3	15,87	13,50	80x32x9,0	128,50*	45x18	72,62*
UNC 3/4-10h.	3	19,05	16,50	95x40x11,0	175,09*	45x18	72,62*
UNC 7/8-9h.	3	22,22	19,50	100x40x14,5	215,54	55x22	101,39
UNC 1"-8h.	3	25,40	22,25	110x50x14,5	291,05*	55x22	97,47*
UNC 1.1/8-7h.	3	28,57	25,00	125x56x18,0	438,84	65x25	144,80
UNC 1.1/4-7h.	3	31,75	28,00	125x56x18,0	552,36	65x25	144,80
UNC 1.3/8-6h.	3	34,92	30,75	150x63x22,0	700,74	65x25	144,80
UNC 1.1/2-6h.	3	38,10	34,00	150x63x24,0	860,37	75x30	225,76
UNC 2"-4,5h.	3	50,80	45,00	180x75x32,0	1.853,17	90x36	

UNF	Uds.	D1 mm	L1 x L2 x mm	M0		C5	
				€	Ø x L3 mm	€	
UNF n°2-64h.	2	2,18	1,85	36x8x2,1	59,57		
UNF n°3-56h.	2	2,51	2,15	40x9x2,1	59,57		
UNF n°4-48h.	2	2,84	2,35	40x9x2,7	37,12	20x5	38,39
UNF n°5-44h.	2	3,17	2,70	45x10x2,7	37,12	20x5	37,03
UNF n°6-40h.	2	3,50	2,95	45x16x3,0	35,47	20x5	37,03
UNF n°8-36h.	2	4,17	3,50	50x12x3,4	35,47	20x7	37,03
UNF n°10-32h.	2	4,83	4,10	50x12x4,9	35,47	20x7	37,03
UNF n°12-28h.	2	5,49	4,60	50x12x4,9	37,12	20x7	37,03
UNF 1/4-28h.	2	6,35	5,50	50x14x4,9	27,07*	25x9	32,70*
UNF 5/16-24h.	2	7,94	6,90	56x22x4,9	28,98*	25x9	36,50*
UNF 3/8-24h.	2	9,52	8,50	63x20x5,5	33,46*	38x10	49,79*
UNF 7/16-20h.	2	11,11	9,90	63x20x6,2	44,42	38x10	48,86
UNF 1/2-20h.	2	12,70	11,50	70x22x7,0	45,43*	38x10	53,22*
UNF 9/16-18h.	2	14,29	12,90	70x22x9,0	59,21	38x10	55,72
UNF 5/8-18h.	2	15,87	14,50	70x22x9,0	76,48*	45x14	72,62*
UNF 3/4-16h.	2	19,05	17,50	80x22x11,0	102,73*	45x14	72,62*
UNF 7/8-14h.	2	22,22	20,40	80x22x14,5	132,03*	55x16	97,47*
UNF 1"-12h.	2	25,40	23,25	90x22x16,0	175,07	55x16	97,47
UNS 1"-14h.	2	25,40	23,60	90x22x14,5	193,93*	55x16	105,91*
UNF 1.1/8-12h.	2	28,57	26,50	90x22x18,0	258,38	65x18	118,70
UNF 1.1/4-12h.	2	31,75	29,50	90x22x20,0	315,56	65x18	150,59
UNF 1.3/8-12h.	2	34,92	32,80	125x35x22,0	425,72	65x18	157,65
UNF 1.1/2-12h.	2	38,10	36,00	125x40x22,0	537,83	75x20	225,76
UNF 2"-12h.	2	50,80	48,38	140x40x29,0	1.330,81	90x22	

\* Disponibles también con rosca izquierda con 100% de recargo sobre los precios tarifados en rosca derecha



JUEGOS DE MACHOS Y TERRAJAS PARA ROSCAR A MANO HSS

Machos y Terrajas  
Verde Rosa

**BSP (GAS)** Ref. M0 **DIN 5157** **TOL ISO 228** Ref. C5 **DIN 5158** Ref. M0T **DIN 352** **TOL 6H** Ref. C5T **DIN 5158** **TOL 6g**  
Ref. M0X

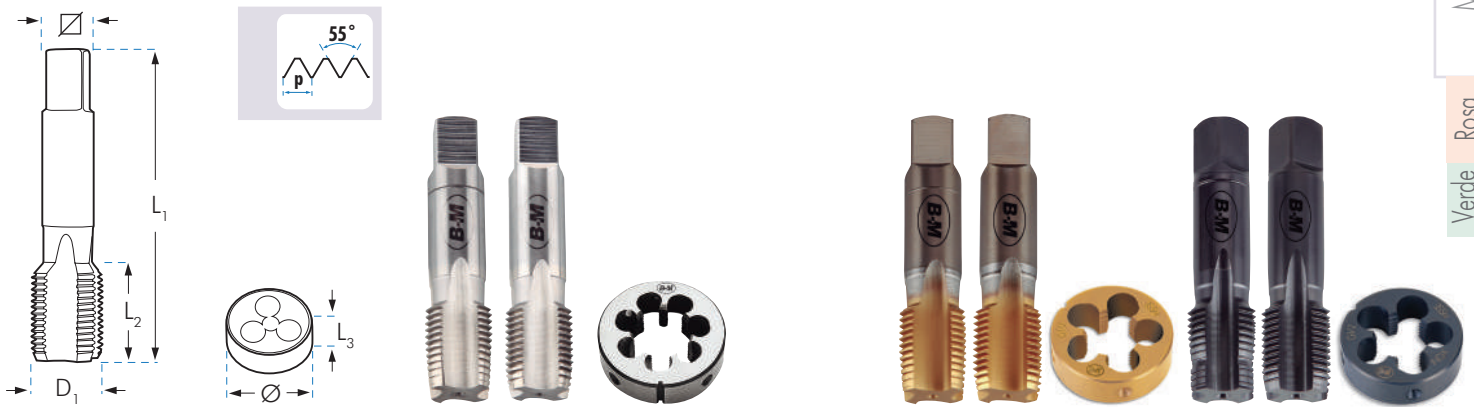

Uds.	D1 mm	L1 x L2 x mm	M0		C5		M0T		C5T		M0X		C5X	
			HSS	€	HSS	€	HSS	€	HSS	€	HSSCo	€	HSSCo	€
G 1/8-28h.	2	9,73	8,80	63 x 20 x 5,5	31,10*	30 x 11	44,53*	G 1/8-28 h.	2	68,30	87,71	78,48	90,32	
G 1/4-19h.	2	13,16	11,80	70 x 22 x 9,0	43,83*	38 x 10	44,29*	G 1/4-19 h.	2	124,28	90,77	141,04	90,56	
G 3/8-19h.	2	16,66	15,25	70 x 22 x 9,0	55,02*	45 x 14	58,66*	G 3/8-19 h.	2	151,62	102,11	175,20	96,96	
G 1/2-14h.	2	20,95	19,00	80 x 22 x 12,0	77,16*	45 x 14	58,66*	G 1/2-14 h.	2	213,70	115,58	236,39	122,62	
G 5/8-14h.	2	22,91	21,00	80 x 22 x 14,5	98,73*	55 x 16	81,38*							
G 3/4-14h.	2	26,44	24,50	90 x 22 x 16,0	120,45*	55 x 16	105,93*	G 3/4-14 h.	2	280,35	188,31	339,31	200,55	
G 7/8-14h.	2	30,20	28,25	90 x 22 x 18,0	162,15	65 x 18	126,11							
G 1"-11h.	2	33,25	30,75	100 x 25 x 20,0	190,95*	65 x 18	127,32*	G 1" -11 h.	2	488,62	251,54	558,09	291,50	
G 1.1/8-11h.	2	37,90	35,50	125 x 40 x 22,0	296,57	75 x 20	179,70							
G 1.1/4-11h.	2	41,91	39,50	125 x 40 x 24,0	323,19*	75 x 20	176,40*							
G 1.3/8-11h.	2	44,32	42,00	125 x 40 x 29,0	438,96	90 x 22	284,03							
G 1.1/2-11h.	2	47,80	45,25	140 x 40 x 29,0	488,43	90 x 22	273,61							
G 1.3/4-11h.	2	53,75	51,25	140 x 40 x 32,0	812,00	105 x 22	284,03							
G 2"-11h.	2	59,61	57,00	160 x 40 x 35,0	902,88	105 x 22	341,83							
G 2.1/4-11h.	2	65,71	63,00	160 x 40 x 39,0	1.546,70	105 x 22								
G 2.1/2-11h.	2	75,18	72,50	160 x 40 x 39,0	2.324,87	120 x 22								
G 2.3/4-11h.	2	81,53	79,00	160 x 40 x 39,0	2.819,12	120 x 22								
G 3"-11h.	2	87,88	85,50	160 x 40 x 39,0	2.934,13	150 x 25								
G 4"-11h.	2	113,03	110,50	180 x 45 x 44,0	4.450,08	180 x 25								

**UNF 3B** Ref. M0 **HSS** **DIN 2181** **TOL 3B**

Uds.	D1 mm	L1 x L2 x mm	€
UNF n°4-48-3B	2	2,84 2,35 40x9x2,7	47,27
UNF n°5-44-3B	2	3,17 2,70 45x10x2,7	47,27
UNF n°6-40-3B	2	3,50 2,95 45x16x3,0	45,17
UNF n°10-32-3B	2	4,83 4,10 50x12x4,9	45,17
UNF n°12-28-3B	2	5,49 4,60 50x12x4,9	47,27
UNF 1/4-28-3B	2	6,35 5,50 50x14x4,9	34,47
UNF 5/16-24-3B	2	7,94 6,90 56x22x4,9	36,91
UNF 3/8-24-3B	2	9,52 8,50 63x20x5,5	42,61
UNF 7/16-20-3B	2	11,11 9,90 63x20x6,2	56,57
UNF 1/2-20-3B	2	12,70 11,50 70x22x7,0	57,87

\* Disponibles también con rosca izquierda con 100% de recargo sobre los precios tarifados en rosca derecha

**JUEGOS DE MACHOS Y TERRAJAS PARA ROSCAR A MANO HSS**

**BSW** Ref. M0 HSS DIN 351 TOL Clase 2  
Ref. C5 HSS DIN 223

DIN BS84 55°



				M0	C5
	Uds.	D1 mm	L1 x L2 x $\nabla$ mm	€	Ø x L3 mm €
W 1/16-60h.	3	1,59	1,15 32x8x2,1	51,14	16x5 68,82
W 3/32-48h.	3	2,38	1,80 40x9x2,1	37,39	20x5 35,51
W 1/8-40h.	3	3,17	2,55 40x14x2,7	26,86*	25x9 28,02*
W 5/32-32h.	3	3,97	3,10 45x17x3,4	27,13	25x9 28,59
W 3/16-24h.	3	4,76	3,60 50x19x4,9	26,86	25x9 28,02
W 7/32-24h.	3	5,55	4,40 50x19x4,9	44,17	25x9 36,60
W 1/4-20h.	3	6,35	5,10 50x20x4,9	30,25*	25x9 28,59*
W 5/16-18h.	3	7,94	6,50 56x20x4,9	36,95*	25x9 29,82*
W 3/8-16h.	3	9,52	7,90 63x22x5,5	40,59*	38x10 43,15*
W 7/16-14h.	3	11,11	9,25 70x22x6,2	54,50	38x10 43,22
W 1/2-12h.	3	12,70	10,50 75x25x7,0	58,47	38x14 42,40
W 9/16-12h.	3	14,29	12,00 80x26x9,0	79,55	38x14 51,79
W 5/8-11h.	3	15,87	13,40 80x27x9,0	91,48*	45x18 61,58*
W 11/16-11h.	3	17,46	15,25 95x32x11,0	215,57	45x18 101,44
W 3/4-10h.	3	19,05	16,50 95x32x11,0	130,22*	45x18 61,68*
W 7/8-9h.	3	22,22	19,25 100x32x14,5	177,85*	55x22 90,69*
W 1"-8h.	3	25,40	21,75 110x36x14,5	217,95*	55x22 91,51*
W 1.1/8-7h.	3	28,57	24,75 125x40x18,0	323,04	65x25 144,10
W 1.1/4-7h.	3	31,75	27,75 125x40x18,0	390,85	65x25 144,15
W 1.3/8-6h.	3	34,92	30,50 150x50x22,0	486,05	65x25 146,81
W 1.1/2-6h.	3	38,10	33,50 150x50x24,0	585,18	75x30 223,17
W 1.5/8-5h.	3	41,27	46,50 150x56x24,0	814,51	75x30 277,89
W 1.3/4-5h.	3	44,45	39,00 160x58x29,0	1.002,47	90x36 349,73
W 1.7/8-4,5h.	3	47,62	42,00 180x65x29,0	1.294,75	90x36 382,67
W 2"-4,5h.	3	50,80	44,50 180x65x32,0	1.359,26	90x36 401,06
W 2.1/4-4h.	3	57,15	50,00 200x85x35,0	2.252,24	105x36
W 2.1/2-4h.	3	63,50	56,50 220x85x39,0	2.739,90	120x36
W 2.3/4-3,5h.	3	69,85	62,00 250x90x44,0	3.912,24	120x36
W 3"-3,5h.	3	76,20	68,00 250x90x44,0	4.526,03	140x36

**BSF** Ref. M0 HSS DIN 5157 TOL ISO 228  
Ref. C5 HSS DIN 223

DIN BS84 55°

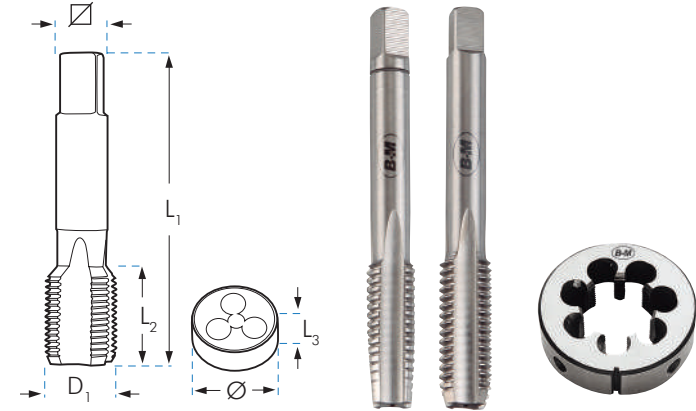

				M0	C5
	Uds.	D1 mm	L1 x L2 x $\nabla$ mm	€	Ø x L3 mm €
BSF 3/16-32h.	2	4,76	4,0 50x19x4,9	101,06	20x7 36,87
BSF 1/4-26h.	2	6,35	5,2 50x20x4,9	41,11	20x7 40,84
BSF 5/16-22h.	2	7,94	6,6 56x20x4,9	47,93	25x9 41,29
BSF 3/8-20h.	2	9,52	8,1 63x22x5,5	55,46	30x11 79,33
BSF 7/16-18h.	2	11,11	9,5 70x22x6,2	66,56	30x11 78,60
BSF 1/2-16h.	2	12,70	11,0 75x25x7,0	75,31	38x10 68,59
BSF 9/16-16h.	2	14,29	12,5 80x26x9,0	90,26	38x10 72,39
BSF 5/8-14h.	2	15,88	14,0 80x26x9,0	118,11	45x14 112,84
BSF 3/4-12h.	2	19,05	16,5 95x33x11,0	180,55	45x14 113,88
BSF 7/8-11h.	2	22,23	19,5 100x33x14,5	215,49	55x22 152,72
BSF 1"-10h.	2	25,40	22,5 110x40x14,5	302,48	55x22 151,03
BSF 1.1/8-9h.	2	28,57	25,5 110x40x16,0	682,52	
BSF 1.1/4-9h.	2	31,75	28,5 125x46x18,0	779,24	
BSF 1.1/2-8h.	2	38,10	34,5 150x55x22,0	1.187,59	

**BSW** **INOX** **TiN**

			MOT	C5T
	Uds.	L1 x L2 x $\nabla$ mm	€	Ø x L3 mm €
W 3/16-24 h.	3	50 x 19 x 4,90	51,27	25x9 51,25
W 1/4-20 h.	3	50 x 20 x 4,90	57,39	25x9 52,19
W 5/16-18 h	3	56 x 20 x 4,90	62,88	25x9 54,25
W 3/8-16 h.	3	63 x 22 x 5,50	74,01	38x10 64,13
W 1/2-12 h.	3	75 x 25 x 7,00	104,44	38x14 86,16



\* Disponibles también con rosca izquierda con 100% de recargo sobre los precios tarifados en rosca derecha



MACHOS Y TERRAJAS PARA ROSCAR A MANO HSS

NPTF

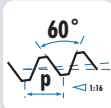

Rosca AMERICANA  
Rosca Cónica estanca

Ref. M0

HSS

Ref. C5

HSS

DIN  
223

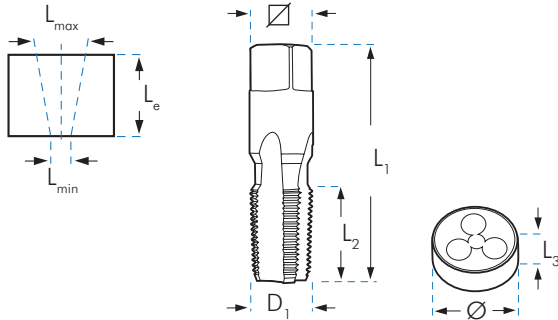

							M0	C5
							€	€
NPTF 1/16-27 h.	1	7,87	6,2	6,00 x 6,41	12,0	54 x 18 x 6,0		25 x 11
NPTF 1/8-27 h.	1	10,22	8,5	8,30 x 8,76	12,0	54 x 19 x 8,0	82,39	38 x 10 179,93
NPTF 1/4-18 h.	1	13,58	11,0	10,70 x 11,40	17,5	62 x 27 x 11,0	115,48	38 x 15 179,93
NPTF 3/8-18 h.	1	17,02	14,5	14,20 x 14,84	17,6	65 x 27 x 13,0	159,41	45 x 14 234,93
NPTF 1/2-14 h.	1	21,21	17,8	17,40 x 18,33	22,8	80 x 35 x 13,0	222,92	45 x 20 234,93
NPTF 3/4-14 h.	1	26,56	23,0	22,80 x 23,68	23,0	83 x 35 x 17,0	340,74	55 x 22 447,76
NPTF 1"-11,5 h.	1	33,19	29,0	28,60 x 29,72	27,4	95 x 44 x 21,0	453,86	65 x 25

NPT

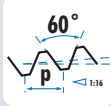

Rosca AMERICANA  
Rosca Cónica no estanca (Briggs)

Ref. M0

HSS

Ref. C5

HSS

DIN  
223

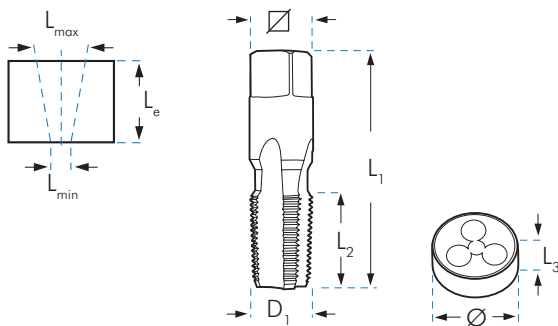

							M0	C5
							€	€
NPT 1/16-27 h.	1	7,89	6,20	EMNPT1/16	6,00 x 6,38	12,0	54 x 18 x 6,0	31,29 25 x 9 103,43
NPT 1/8-27 h.	1	10,24	8,50	EMNPT1/8	8,30 x 8,73	12,0	54 x 19 x 8,0	31,29 30 x 11 76,47
NPT 1/4-18 h.	1	13,62	11,00	EMNPT1/4	10,70 x 11,35	17,5	62 x 27 x 11,0	43,89 38 x 14 76,47
NPT 3/8-18 h.	1	17,05	14,50	EMNPT3/8	14,20 x 14,80	17,6	65 x 27 x 13,0	60,57 45 x 18 99,83
NPT 1/2-14 h.	1	21,23	17,80	EMNPT1/2	17,40 x 18,32	22,8	80 x 35 x 13,0	84,69 45 x 18 99,83
NPT 3/4-14 h.	1	26,57	23,00	-	22,80 x 23,66	23,0	83 x 35 x 17,0	129,49 55 x 22 182,64
NPT 1"-11,5 h.	1	33,23	29,00	-	28,60 x 29,69	27,4	95 x 44 x 21,0	144,21 65 x 25 219,56
NPT 1.1/4-11,5 h.	1	41,98	37,50	-	37,40 x 38,45	28,1	125 x 33 x 24,0	236,44 75 x 26 272,83
NPT 1.1/2-11,5 h.	1	48,05	44,00	-	43,40 x 44,52	28,4	140 x 33 x 29,0	359,28 90 x 27 380,65
NPT 2"-11,5 h.	1	60,09	56,00	-	55,50 x 56,56	28,4	160 x 33 x 35,0	560,90 105 x 36 529,96
NPT 2.1/2"-8h.	1	73,03	67,00	-	68,68 x 69,08	28,9	200 x 45 x 39,0	685,36
NPT 3"-8h.	1	88,90	82,00	-	84,45 x 84,86	30,5	220 x 48 x 39,0	963,36

\* Ver escariador previo pag.135



**MACHOS Y TERRAJAS PARA ROSCAR A MANO HSS**

Machos y Terrajas

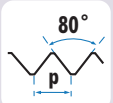
Verde

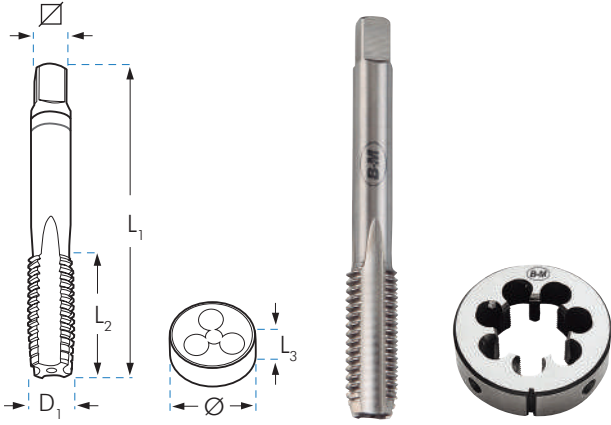

**PG**  Ref. M0 **HSS** **DIN 40430** Ref. C5 **HSS** **DIN 223**

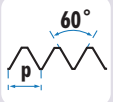

					M0	C5		
		Uds.	D1 mm		L1 x L2 x mm	€	Ø x L3 mm	€
Pg 7	20h.	1	12,5	11,50	70x20x7,0	29,99	38x10	56,75
Pg 9	18h.	1	15,2	14,00	70x20x9,0	38,13	38x10	56,75
Pg 11	18h.	1	18,6	17,25	80x22x11,0	52,94	45x14	71,06
Pg 13,5	18h.	1	20,4	19,00	80x22x12,0	58,06	45x14	71,06
Pg 16	18h.	1	22,5	21,25	80x22x14,5	69,73	55x16	91,68
Pg 21	16h.	1	28,3	27,00	90x22x18,0	102,54	65x18	130,31
Pg 29	16h.	1	37,0	35,50	100x25x22,0	203,61	65x18	130,31
Pg 36	16h.	1	47,0	45,50	140x32x29,0	343,89	90x22	334,01
Pg 42	16h.	1	54,0	52,50	140x36x32,0	408,38	105x22	334,01
Pg 48	16h.	1	59,3	58,00	160x36x35,0	515,04	105x22	442,92

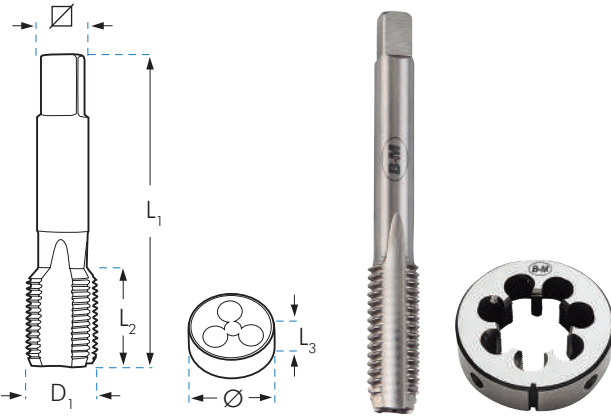

**NPSF**  Rosca AMERICANA Rosca Cilíndrica estanca Ref. M0 **HSS** Ref. C5 **HSS** **DIN 223**

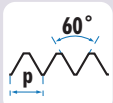

					M0	C5		
		Uds.	D1 mm		L1 x L2 x mm	€	Ø x L3 mm	€
NPSF 1/8-27 h.	1	10,05	8,75	63x18x5,5	124,07	38x10	216,14	
NPSF 1/4-18 h.	1	13,35	11,30	70x20x9,0	179,29	38x10	216,14	
NPSF 3/8-18 h.	1	16,78	14,70	70x20x9,0	247,99	45x14	274,95	
NPSF 1/2-14 h.	1	20,87	18,20	80x22x12,0	324,19	45x14	274,95	
NPSF 3/4-14 h.	1	26,23	23,50	90x22x16,0	493,27	55x16	594,33	
NPSF 1"-11,5 h.	1	32,81	29,50	100x25x20,0				

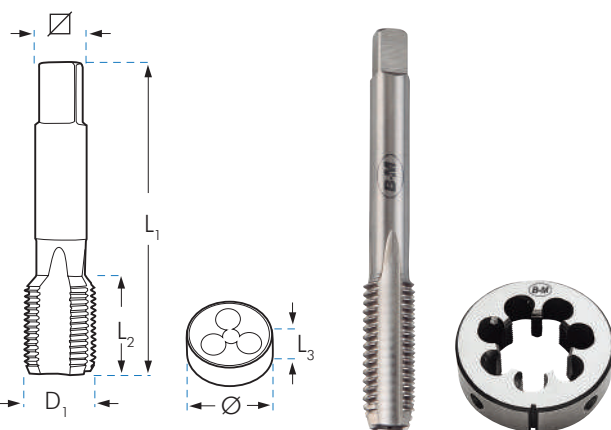
**NPS (M)**  Rosca AMERICANA Rosca Cilíndrica no estanca Ref. M0 **HSS** Ref. C5 **HSS** **DIN 223**



					M0	C5		
		Uds.	D1 mm		L1 x L2 x mm	€	Ø x L3 mm	€
NPS 1/8-27 h.	1	10,20	8,9	63x18x5,5	102,81	38x10	180,08	
NPS 1/4-18 h.	1	13,60	11,7	70x20x9,0	81,82	38x10	180,08	
NPS 3/8-18 h.	1	17,00	15,0	70x20x9,0	113,16	45x14	229,12	
NPS 1/2-14 h.	1	21,20	18,6	80x22x12,0	147,90	45x14	229,12	
NPS 3/4-14 h.	1	26,55	24,0	90x22x16,0	214,79	55x16	453,88	
NPS 1"-11,5 h.	1	33,20	30,0	100x25x20,0	300,32	65x18	445,48	



JUEGOS DE MACHOS Y TERRAJAS PARA ROSCAR A MANO HSS

**BSPT**

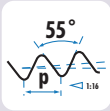

Ref. M0

**HSS**

**DIN 5157**

Ref. C5

**HSS**

**DIN 223**

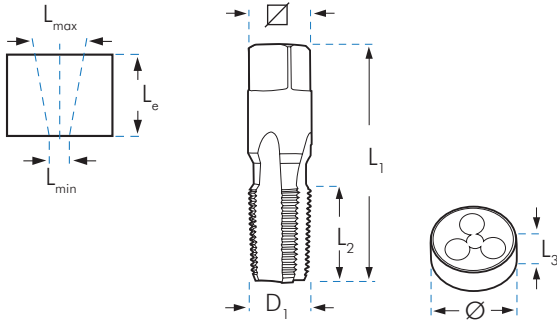

Uds.	D1 mm	Lmin x Lmax mm	Le mm	L1 x L2 x mm	M0		C5		
					€	Ø x L3 mm	€		
BSPT 1/8-28 h.	1	9,73	8,30	8,00 x 8,50	10,1	65 x 19 x 5,5	29,04	30 x 11	93,51
BSPT 1/4-19 h.	1	13,16	11,00	10,70 x 11,35	15,0	70 x 25 x 9,0	40,92	38 x 14	93,51
BSPT 3/8-19 h.	1	16,66	14,50	14,15 x 14,25	15,4	70 x 25 x 9,0	56,84	45 x 16	121,79
BSPT 1/2-14 h.	1	20,95	18,10	17,60 x 18,50	20,5	80 x 31 x 12,0	79,57	55 x 22	121,79
BSPT 5/8-14 h.	1	22,91	20,00	19,50 x 20,40	22,4	80 x 36 x 14,5	139,56	55 x 19	254,12
BSPT 3/4-14 h.	1	26,44	23,50	23,00 x 24,00	21,8	85 x 33 x 16,0	129,85	55 x 22	229,98
BSPT 7/8-14 h.	1	30,20	27,25	26,65 x 28,75	24,0	100 x 36 x 18,0	253,24	65 x 22	332,00
BSPT 1"-11 h.	1	33,25	29,60	29,00 x 30,20	26,0	110 x 38 x 20,0	205,64	65 x 25	265,58

**BA**

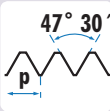

Ref. M0

**HSS**

**DIN 352**

Ref. C5

**HSS**

**DIN 223**

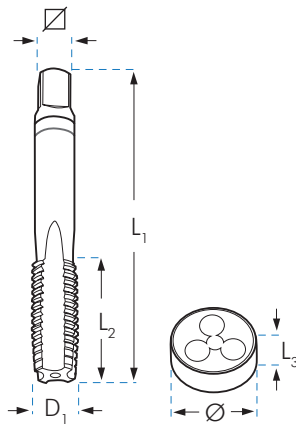

Uds.	D1 mm	L1 x L2 x mm	M0		C5			
			€	Ø x L3 mm	€			
BA-0	1,00	3	6,0	5,1	50 x 18 x 4,9	180,97	20 x 5	144,15
BA-1	0,90	3	5,3	4,5	50 x 18 x 4,9	180,97	20 x 5	144,15
BA-2	0,81	3	4,7	4,0	50 x 17 x 4,9	180,97	20 x 5	144,15
BA-3	0,73	3	4,1	3,4	45 x 14 x 3,4	194,47	20 x 5	144,15
BA-4	0,66	3	3,6	3,0	45 x 14 x 3,0	194,47	20 x 5	144,15
BA-5	0,59	3	3,2	2,6	45 x 14 x 3,0	232,37	20 x 5	144,15
BA-6	0,53	3	2,8	2,3	40 x 12 x 2,7	232,37	20 x 5	144,15
BA-7	0,48	3	2,5	2,0	40 x 10 x 2,1	255,48	20 x 5	144,15
BA-8	0,43	3	2,2	1,8	36 x 10 x 2,1	255,48	20 x 5	144,15



**JUEGOS DE MACHOS Y TERRAJAS PARA ROSCAR A MANO HSS**

Machos y Terrajas

Verde



**UNx8**  Rosca AMERICANA Ref. M0 **HSS** **DIN 2181** **TOL 2B** Ref. C5 **HSS** **DIN 223** **TOL 2a**



	Uds.	D1 mm		L1 x L2 x mm	M0		C5	
					€	Ø x L3 mm	€	
UN 1"1/8-8h.	2	28,57	25,40	138x65x17,0	341,26	65x25	380,82	
UN 1"1/4-8h.	2	31,75	28,50	146x65x19,5	442,54	65x25	380,82	
UN 1"3/8-8h.	2	34,92	31,75	154x76x21,0	550,41	65x25	379,16	
UN 1"1/2-8h.	2	38,10	35,00	162x76x23,5	629,90	75x30	429,23	
UN 1"5/8-8h.	2	41,27	38,10	170x80x25,0	783,13	75x30	449,28	
UN 1"3/4-8h.	2	44,45	41,25	178x81x27,0	976,00	90x36	599,05	
UN 1"7/8-8h.	2	47,62	44,45	186x90x29,0	1.217,61	90x36	640,97	
UN 2"-8h.	2	50,80	47,63	194x90x31,5	1.157,59	90x36	648,97	
UN 2"1/4-8h.	2	57,15	54,00	208x90x36,0		120x36		
UN 2"1/2-8h.	2	63,50	60,35	220x100x40		120x36		
UN 2"3/4-8h.	2	69,85	66,70	234x104x39		120x36		
UN 3"-8h.	2	76,20	73,05	248x115x49		120x36		

**UNEF**  Rosca AMERICANA Ref. M0 **HSS** **DIN 2181** **TOL 2B** Ref. C5 **HSS** **DIN 223** **TOL 2a**



	Uds.	D1 mm		L1 x L2 x mm	M0		C5	
					€	Ø x L3 mm	€	
UNEF 1/4-32h.	2	6,35	5,55	65x28x4,9	91,72	20x7	94,89	
UNEF 5/16-32h.	2	7,94	7,15	70x30x6,0	102,47	25x9	94,89	
UNEF 3/8-32h.	2	9,52	8,70	75x33x7,0	117,27	30x11	147,33	
UNEF 7/16-28h.	2	11,11	10,20	81x38x6,0	149,28	30x11	147,33	
UNEF 1/2-28h.	2	12,70	11,80	86x44x7,0	168,67	38x10	147,33	
UNEF 9/16-24h.	2	14,29	13,20	92x44x8,0	197,31	38x10	147,33	
UNEF 5/8-24h.	2	15,87	14,80	93x47x9,0	274,65	45x14	236,15	
UNEF 3/4-20h.	2	19,05	17,80	108x52x11,0	406,69	45x14	236,15	
UNEF 7/8-20h.	2	22,22	20,95	120x58x13,0	678,89	55x16	313,43	
UNEF 1"-20h.	2	25,40	24,20	130x65x15,0	581,92	55x16	288,61	



**JUEGOS DE MACHOS PARA ROSCAR A MANO APLICACIONES ESPECIALES**

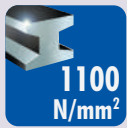

Ref. MOMD

**HSSCo**  
5%

**DIN**  
352

**OX**



ESPECIAL MATERIALES DUROS  
( ≤ 1100 N/mm<sup>2</sup> = 40HRc )

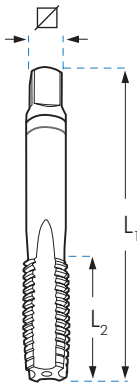

				MOMD	
	Uds.		L1 x L2 x	mm	€
M 3 x 0,50	3	2,50	40 x 11 x 2,7		31,68
M 4 x 0,70	3	3,30	45 x 13 x 3,4		31,68
M 5 x 0,80	3	4,20	50 x 17 x 4,9		32,71
M 6 x 1,00	3	5,00	50 x 19 x 4,9		33,67
M 8 x 1,25	3	6,80	56 x 20 x 4,9		38,28
M 10 x 1,50	3	8,50	70 x 22 x 5,5		49,14
M 12 x 1,75	3	10,20	75 x 24 x 7,0		70,36
M 14 x 2,00	3	12,00	80 x 26 x 9,0		83,29
M 16 x 2,00	3	14,00	80 x 27 x 9,0		110,66
M 18 x 2,50	3	15,50	95 x 30 x 11,0		170,18
M 20 x 2,50	3	17,50	95 x 32 x 12,0		188,95

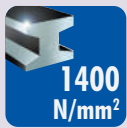

Ref. MOC

**HSS**  
PM

**TiAlSiN**



ESPECIAL MATERIALES MUY DUROS  
( ≤ 1400 N/mm<sup>2</sup> = 44HRc )

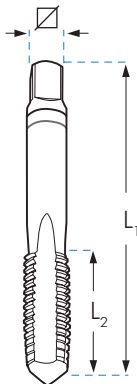

				MOC	
	Uds.		L1 x L2 x	mm	€
M 3 x 0,50	3	2,50	40 x 11 x 2,7		83,36
M 4 x 0,70	3	3,30	45 x 13 x 3,4		89,94
M 5 x 0,80	3	4,20	50 x 17 x 4,9		91,07
M 6 x 1,00	3	5,00	50 x 19 x 4,9		91,07
M 8 x 1,25	3	6,80	56 x 20 x 4,9		102,65
M 10 x 1,50	3	8,50	70 x 22 x 5,5		126,88
M 12 x 1,75	3	10,20	75 x 24 x 7,0		154,25
M 14 x 2,00	3	12,00	80 x 26 x 9,0		189,26
M 16 x 2,00	3	14,00	80 x 27 x 9,0		226,77
M 18 x 2,50	3	15,50	95 x 30 x 11,0		314,40
M 20 x 2,50	3	17,50	95 x 32 x 12,0		346,03

**Al**

Ref. MOAL

**HSS**

**BRILLANTE**



ESPECIAL ALUMINIO

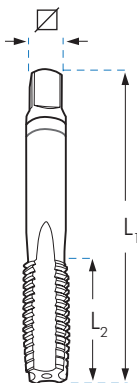

				MOAL	
	Uds.		L1 x L2 x	mm	€
M 3 x 0,50	3	2,50	40 x 11 x 2,7		26,06
M 4 x 0,70	3	3,30	45 x 13 x 3,4		25,31
M 5 x 0,80	3	4,20	50 x 17 x 4,9		26,82
M 6 x 1,00	3	5,00	50 x 19 x 4,9		26,82
M 8 x 1,25	3	6,80	56 x 20 x 4,9		32,92
M 10 x 1,50	3	8,50	70 x 22 x 5,5		40,19
M 12 x 1,75	3	10,20	75 x 24 x 7,0		56,58
M 14 x 2,00	3	12,00	80 x 26 x 9,0		65,03
M 16 x 2,00	3	14,00	80 x 27 x 9,0		92,30
M 18 x 2,50	3	15,50	95 x 30 x 11,0		122,33
M 20 x 2,50	3	17,50	95 x 32 x 12,0		137,90

**JUEGOS DE MACHOS Y TERRAJAS PARA ROSCAR A MANO INOXIDABLE**
**M**
**INOX**

 Ref. MOT  
 Ref. MOX

**DIN  
352**
**TOL  
6H**
**TiN**

 Ref. C5T  
 Ref. C5X

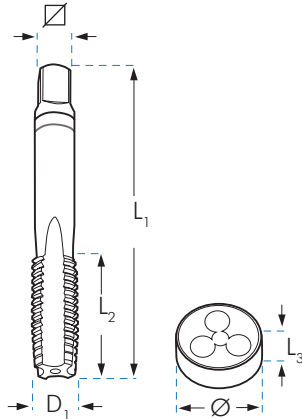
**DIN  
223**
**TOL  
6g**
**OX**

	Uds.	L1 x L2 x $\nabla$ mm	MOT	C5T	MOX	C5X	$\varnothing$ x L3 mm
			HSS <b>TiN</b> €	HSS <b>TiN</b> €	HSSCo <b>OX</b> €	HSSCo <b>OX</b> €	
M 2 x 0,40	3	36 x 9 x 2,10					
M 3 x 0,50	3	40 x 11 x 2,70	37,33	55,91	31,42	21,47	20 x 5
M 4 x 0,70	3	45 x 13 x 3,40	39,22	55,91	31,42	21,47	20 x 5
M 5 x 0,80	3	50 x 16 x 4,90	41,60	55,91	32,70	24,10	20 x 7
M 6 x 1,00	3	50 x 19 x 4,90	41,60	55,91	32,61	24,45	20 x 7
M 8 x 1,00	2	50 x 19 x 4,90	36,57				
M 8 x 1,25	3	56 x 22 x 4,90	47,99	57,32	37,95	26,52	25 x 9
M 10 x 1,00	2	63 x 18 x 5,50	42,20				
M 10 x 1,50	3	70 x 24 x 5,50	63,90	75,25	48,82	33,65	30 x 11
M 12 x 1,50	2	70 x 20 x 7,00	53,73				
M 12 x 1,75	3	75 x 29 x 7,00	74,15	83,44	69,91	35,54	38 x 14
M 14 x 1,50	2	70 x 20 x 9,00	64,52				
M 14 x 2,00	3	80 x 30 x 9,00	89,67	83,44	77,42	35,54	38 x 14
M 16 x 2,00	3	80 x 32 x 9,00	112,60	102,83	106,11	47,72	45 x 18
M 18 x 2,50	3	95 x 40 x 11,00	139,59		144,91		
M 20 x 2,50	3	95 x 40 x 12,00	144,75		160,84		
M 22 x 2,50	3	100 x 40 x 14,50	183,10				
M 24 x 3,00	3	110 x 50 x 14,50	220,64				

**M**

TERRAJAS HEXAGONALES HSS PARA ROSCAR A MANO

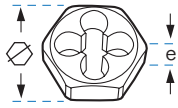

**BSP  
(GAS)**

**HSS**

**DIN  
382**

C5HG

		€
G 1/8 x 28h.	27 x 11	79,66
G 1/4 x 19h.	36 x 10	79,66
G 3/8 x 19h.	41 x 14	99,62
G 1/2 x 14h.	41 x 14	99,62
G 5/8 x 14h.	50 x 16	234,57
G 3/4 x 14h.	50 x 16	234,57
G 7/8 x 14h.	60 x 18	236,65
G 1" x 11h.	60 x 18	236,65
G1.1/4 x 11h.	70 x 20	315,54
G1.1/2 x 11h.	85 x 22	532,33
G 2" x 11h.	100 x 22	801,03

**UNC**

**HSS**

**DIN  
382**

C5HNC

		€
UNC 1/4-20h	18 x 7	32,99
UNC 5/16-18h	21 x 9	41,06
UNC 3/8-16h	27 x 11	49,56
UNC 7/16-14h	27 x 11	73,13
UNC 1/2-13h	36 x 14	73,41
UNC 9/16-12h	36 x 14	87,72
UNC 5/8-11h	41 x 18	67,97
UNC 3/4-10h	41 x 18	108,11
UNC 7/8-9h	50 x 22	153,42
UNC 1"-8h	50 x 22	153,42
UNC 1.1/8-7h	60 x 25	202,84
UNC 1.1/4-7h	60 x 25	202,84

**UNF**

**HSS**

**DIN  
382**

C5HNF

		€
UNF 1/4-28h.	18 x 7	34,98
UNF 5/16-24h.	21 x 9	43,72
UNF 3/8-24h.	27 x 11	52,61
UNF 7/16-20h.	27 x 11	77,51
UNF 1/2-20h.	36 x 10	78,70
UNF 9/16-18h.	36 x 10	87,72
UNF 5/8-18h.	41 x 14	109,43
UNF 3/4-16h	41 x 14	114,61
UNF 7/8-14h	50 x 16	144,94
UNF 1"-12h	50 x 16	151,95
UNS 1"-14h	50 x 16	151,95
UNF 1.1/8-12h	60 x 18	202,84
UNF 1.1/4-12h	60 x 18	202,84

**M**

**HSS**

**DIN  
382**

C5HM

		€
M 3 x 0,35	18 x 5	36,18
M 3 x 0,50	19 x 5	36,18
M 3,5 x 0,60	18 x 5	36,18
M 4 x 0,50	18 x 5	36,18
M 4 x 0,70	19 x 5	36,18
M 5 x 0,50	18 x 5	36,18
M 5 x 0,75	18 x 5	36,18
M 5 x 0,80	19 x 7	36,18
M 6 x 0,75	18 x 7	36,18
M 6 x 1,00	19 x 7	36,18
M 7 x 0,75	21 x 9	38,45
M 7 x 1,00	21 x 9	38,45
M 8 x 0,75	21 x 9	38,45
M 8 x 1,00	21 x 9	38,45
M 8 x 1,25	22 x 9	38,45
M 9 x 0,75	21 x 9	45,27
M 9 x 1,00	21 x 9	45,27
M 9 x 1,25	22 x 9	45,27
M 10 x 1,00	27 x 11	45,27
M 10 x 1,25	27 x 11	45,27
M 10 x 1,50	27 x 11	45,27
M 11 x 1,00	27 x 11	75,42
M 11 x 1,50	27 x 11	75,42
M 12 x 1,25	36 x 10	75,42
M 12 x 1,50	36 x 10	75,42
M 12 x 1,75	36 x 10	63,37
M 14 x 1,25	36 x 14	85,71
M 14 x 1,50	36 x 10	85,71
M 14 x 2,00	36 x 10	63,37
M 15 x 1,00	36 x 14	99,41
M 15 x 1,50	41 x 14	99,41
M 16 x 1,00	41 x 14	99,41
M 16 x 1,50	41 x 14	99,41

C5HM

		€
M 16 x 2,00	41 x 18	99,41
M 18 x 1,00	41 x 14	99,41
M 18 x 1,50	41 x 14	99,41
M 18 x 2,50	41 x 18	99,41
M 20 x 1,00	41 x 14	99,41
M 20 x 1,50	41 x 14	99,41
M 20 x 2,00	41 x 18	99,41
M 20 x 2,50	41 x 18	99,41
M 22 x 1,00	50 x 16	125,70
M 22 x 1,50	50 x 16	125,70
M 22 x 2,00	50 x 16	125,70
M 22 x 2,50	50 x 16	125,70
M 24 x 1,00	50 x 16	202,84
M 24 x 1,50	50 x 16	202,84
M 24 x 2,00	50 x 16	202,84
M 24 x 3,00	50 x 22	125,70
M 27 x 1,50	60 x 18	169,95
M 27 x 2,00	60 x 18	169,95
M 27 x 3,00	60 x 25	141,62
M 30 x 1,00	60 x 18	169,95
M 30 x 1,50	60 x 18	169,95
M 30 x 2,00	60 x 18	169,95
M 30 x 3,00	60 x 18	169,95
M 30 x 3,50	60 x 25	141,62
M 33 x 1,50	60 x 18	190,30
M 33 x 2,00	60 x 18	190,30
M 33 x 3,50	60 x 25	158,58
M 35 x 1,50	60 x 18	196,18
M 36 x 1,50	60 x 18	196,18
M 36 x 2,00	60 x 18	196,18
M 36 x 3,00	60 x 18	196,18
M 36 x 4,00	60 x 25	163,49

**BSW**

**HSS**

**DIN  
382**

C5HW

		€
BSW 1/8 x 40h.	19 x 5	45,27
BSW 3/16 x 24h.	19 x 7	45,27
BSW 1/4 x 20h.	19 x 7	45,27
BSW 5/16 x 18h.	22 x 9	47,52
BSW 3/8 x 16h.	27 x 11	56,56
BSW 7/16 x 14h.	27 x 11	56,56
BSW 1/2 x 12h.	36 x 14	67,90

C5HW

		€
BSW 9/16 x 12h.	36 x 14	67,90
BSW 5/8 x 11h.	41 x 18	100,35
BSW 3/4 x 10h.	41 x 18	100,35
BSW 7/8 x 9h.	50 x 22	147,07
BSW 1" x 8h.	50 x 22	147,07
BSW 1.1/8 x 7h.	60 x 25	253,50



## GALGAS PARA LA COMPROBACIÓN DE PASOS DE ROSCAS



	TIPOS DE ROSCA	RANGO DE PASOS		GAM
		Métricos	Ingleses	€
GAM	Pasos rosca métrica	0,25 - 2,5		10,22
GAMW	Pasos rosca métrica /rosca Inglesa	0,25 - 6,0	62h - 4h	18,51

## CONJUNTO DE GUIAS PARA COJINETES M3-M12

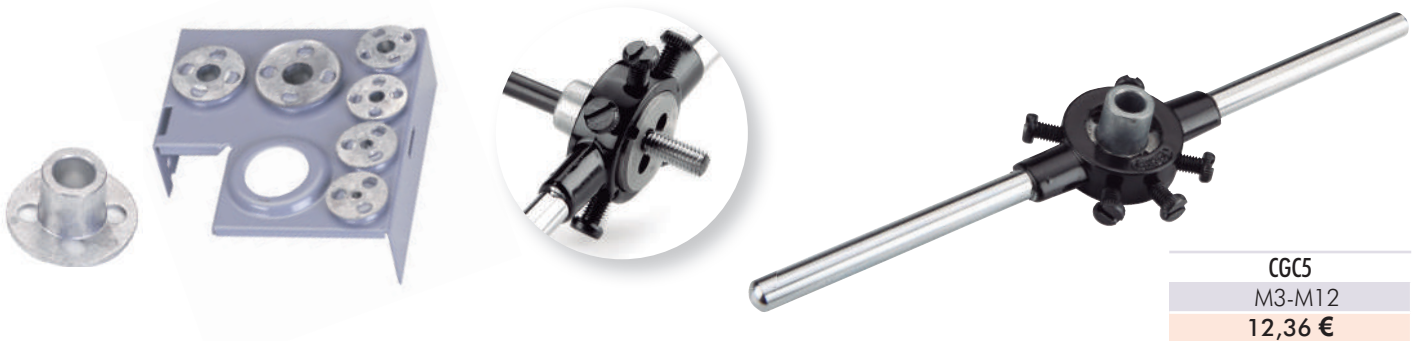

CG5  
M3-M12  
12,36 €

## ALARGADOR DE MACHOS

DIN  
377

DIN 10

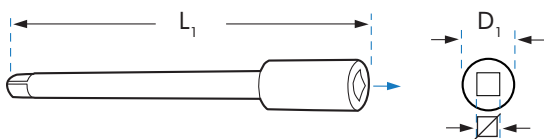

	∅ x L1 mm	D1	AL €
AL21	2,1 x 60	6,0	7,54
AL24	2,4 x 70	6,0	7,54
AL27	2,7 x 80	7,0	7,54
AL30	3,0 x 90	7,0	7,54
AL34	3,4 x 95	8,0	8,17
AL38	3,8 x 95	9,0	8,53
AL43	4,3 x 105	10,0	9,50
AL49	4,9 x 110	11,0	9,17
AL55	5,5 x 115	12,0	9,32
AL62	6,2 x 120	14,0	11,66
AL70	7,0 x 125	15,0	12,15
AL80	8,0 x 125	17,0	15,18
AL90	9,0 x 135	19,0	15,58

	∅ x L1 mm	D1	AL €
AL100	10,0 x 140	21,0	21,53
AL110	11,0 x 150	23,0	21,84
AL120	12,0 x 160	25,0	23,51
AL130	13,0 x 165	27,0	36,78
AL145	14,5 x 175	29,0	37,29
AL160	16,0 x 185	30,0	39,45
AL180	18,0 x 195	33,0	44,97
AL200	20,0 x 220	36,0	59,96
AL220	22,0 x 220	40,0	87,64
AL240	24,0 x 235	42,0	134,22
AL260	26,0 x 245	45,0	141,74
AL290	29,0 x 260	55,0	163,52
AL320	32,0 x 280	55,0	201,31

Máxima Resistencia  
150 kg/mm<sup>2</sup>

**GIRAMACHOS DE ACERO FORJADO**

Ref. GAPRO

**DIN 1814**

- Cuerpo de Acero Forjado.
- Soporta esfuerzos hasta 150 kg/mm<sup>2</sup>.
- Máxima resistencia y durabilidad.

- Mayor precisión y firmeza en el amarre.
- Su rosca de precisión conforma un conjunto sólido y robusto.
- Maneral antideslizante, mayor agarre en el taller.



GAPRO

Nº NORMA	Nº 0	Nº 1	Nº 1.1/2	Nº 2	Nº 3	Nº 4	Nº 5
	M1-M8 2,00-5,00	M1-M10 2,00-6,30	M1-M12 2,50-7,00	M1-M12 2,50-8,00	M5-M20 4,00-13,00	M5-M27 4,00-16,00	M9-M32 5,50-20,00
€	18,20	19,23	20,43	25,82	36,54	58,42	123,65

Ref. GA

**DIN 1814**

- Cuerpo de Aleación de Zinc.
- Alta resistencia y durabilidad.
- Alta precisión y firmeza en el amarre.



GA

Nº NORMA	Nº 0	Nº 1	Nº 1.1/2	Nº 2	Nº 3	Nº 4	Nº 5	Nº 7	Nº 8
	M1-M8 1,50-5,00	M1-M10 2,00-7,00	M1-M12 2,00-8,00	M4-M12 2,50-10,00	M5-M20 3,50-14,00	M9-M27 4,00-15,00	M13-M32 5,50-19,00	M22-M56 14,00-31,50	M33-M64 16,00-40,00
€	15,29	16,16	17,17	21,69	30,70	49,10	103,91	211,25	335,36

**VOLVEDORES PARA TERRAJAS DE ROSCAR**

Ref. VA

**DIN 225**



**IMPORTANTE:** A la hora de cursar sus pedidos de volvedores, indiquen el espesor del volvedor que corresponda, según detalle de espesores que indicamos en la tarifa de terrajas.

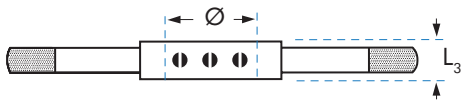

VA

Ø x L3 mm	16x5	20x5	20x7	25x9	30x11	38x10	38x14	45x14	45x18	55x16	55x22	65x18	65x25
€	8,48	9,40	9,40	10,73	12,99	16,99	16,97	20,85	21,01	26,95	28,23	38,63	38,63
Ø x L3 mm	75x20	75x30	90x22	90x36	105x22	105x36	120x22	120x36	130x25	130x36	140x25	140x36	
€	66,93	70,06	84,78	91,34	126,14	126,14	328,05	328,05	341,05	341,05	358,64	358,64	

Ref. VA

**PULGADAS**



VA

Ø mm	20,60	25,40	38,10	50,80	63,50	76,20	88,90
PULGADAS	13/16"	1"	1.1/2"	2"	2.1/2"	3"	3.1/2"
€	9,21	10,92	16,34	24,24	38,25	70,74	89,61

NOTA: Los volvedores para terrajas en Ø exteriores en pulgadas, están en desuso.

## GIRAMACHOS EN T CON CRIQUE

Ref. TC

**TIPO**  
**T**

SERIE CORTA



	CAPACIDAD mm mín.-máx.	Para mangos de machos		L <sub>1</sub> mm	PESO g	CALIDAD	TC
		DIN	ISO				€
TC3B	2,6 - 5,5	M3 - 8	M3 - 6	85	180	1ª Calidad	24,98
TC4B	4,6 - 8,0	M5 - 12	M6 - 12	110	300	1ª Calidad	33,73
TC1B	2,6 - 5,5	M3 - 8	M3 - 6	85	180	2ª Calidad	18,91
TC2B	4,6 - 8,0	M5 - 12	M6 - 12	110	300	2ª Calidad	25,36

Ref. TL

**TIPO**  
**T**

SERIE LARGA



	CAPACIDAD mm mín.-máx.	Para mangos de machos		L <sub>1</sub> mm	PESO g	CALIDAD	TL
		DIN	ISO				€
TL3	2,6 - 5,5	M3 - 8	M3 - 6	250	250	1ª Calidad	37,98
TL4	4,6 - 8,0	M5 - 12	M6 - 12	300	440	1ª Calidad	45,22
TL1	2,6 - 5,5	M3 - 10	M3 - 6	250	250	2ª Calidad	29,99
TL2	4,6 - 8,0	M5 - 12	M6 - 12	300	440	2ª Calidad	35,74

## EXPOSITOR DE METACRILATO

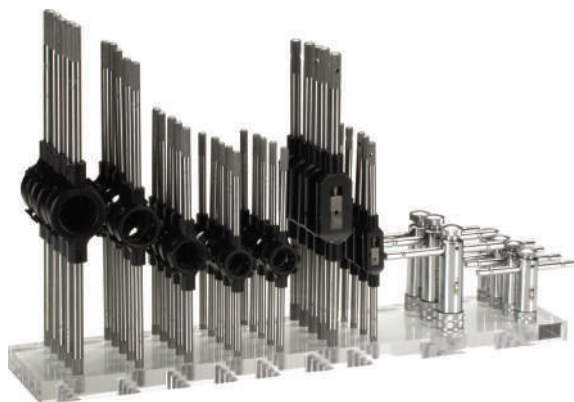

Dimensiones: 500 x 320 x 110 mm

	GV-01			€	
GV-01	Nº $\frac{1}{5}$ $\frac{1}{2}$	Nº $\frac{2}{5}$	$\frac{20 \times 5}{5}$ $\frac{20 \times 7}{5}$ $\frac{25 \times 9}{5}$ $\frac{30 \times 11}{5}$ $\frac{38 \times 14}{5}$	TC1   TC2 4   4	657,70

**CONJUNTOS DE MACHOS Y COJINETES EN CAJA METÁLICA HSS**



**M3  
M12**

**HSS**

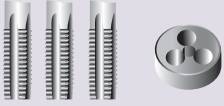

Ref. D624

**CONTENIDO**

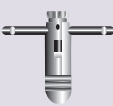
					Nº Piezas	1ª Calidad €	2ª Calidad €
D624	M3 - M4 - M5 - M6 - M8 - M10 - M12	Nº 1.1/2	25 x 9	-	30	219,03	198,69

**CONJUNTOS DE COJINETES EN CAJA METÁLICA HSS**



**M3  
M12**

**HSS**



Ref. D671

**CONTENIDO**

					Nº Piezas	1ª Calidad €	2ª Calidad €
D671	M3 - M4 - M5 - M6 - M8 - M10 - M12	20 x 5 30 x 11	20 x 7 38 x 14	25 x 9	12	216,06	183,00
D671I (Izq)	 M3 - M4 - M5 - M6 - M8 - M10 - M12	20 x 5 30 x 11	20 x 7 38 x 14	25 x 9	12	432,10	365,98



**CONJUNTOS DE MACHOS Y COJINETES EN CAJA METÁLICA HSS Y HSSCo**

Machos y Terrajas

Verde

**M3  
M12**



**HSS**

**HSSCo  
5%**

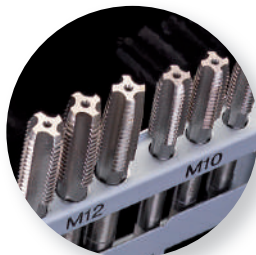

Ref. D621



Ref. D655

**CONTENIDO**

							Nº Piezas	1ª Calidad €	2ª Calidad €
D621	M3 - M4 - M5 - M6 M8 - M10 - M12	2.5 / 3.3 / 4.2 / 5.0 6.8 / 8.5 / 10.2 mm	Nº 1 Nº 2	20 x 5 20 x 7 25 x 9 30 x 11 38 x 14		TC1	43	439,19	321,91
D652	M3 - M4 - M5 - M6 M8 - M10 - M12	2.5 / 3.3 / 4.2 / 5.0 6.8 / 8.5 / 10.2 mm	Nº 1 Nº 2	20 x 5 20 x 7 25 x 9 30 x 11 38 x 14		-	42	425,13	305,70
D662	M3-M4-M5-M6-M7 M8-M9-M10-M11-M12	-	Nº 1 Nº 2	20 x 5 20 x 7 25 x 9 30 x 11 38 x 14		TC1	48	654,26	575,48
D651	M3 - M4 - M5 - M6 M8 - M10 - M12	-	Nº 1 Nº 2	20 x 5 20 x 7 25 x 9 30 x 11 38 x 14		-	35	335,55	308,69
D655* (HSSCo)	M3 - M4 - M5 - M6 M8 - M10 - M12	2.5 / 3.3 / 4.2 / 5.0 6.8 / 8.5 / 10.2 mm	Nº 1 Nº 2	20 x 5 20 x 7 25 x 9 30 x 11 38 x 14		TC1	43	700,63	616,28
D621I (Izq)	M3 - M4 - M5 - M6 M8 - M10 - M12	2.5 / 3.3 / 4.2 / 5.0 6.8 / 8.5 / 10.2 mm	Nº 1 Nº 2	20 x 5 20 x 7 25 x 9 30 x 11 38 x 14		TC1	43	685,92	598,19



\*

**HSSCo  
5%**



CONJUNTOS DE MACHOS Y COJINETES EN CAJA METÁLICA HSS Y HSSCo CON GUÍAS PARA COJINETES

M3  
M12

HSS

HSSCo  
5%



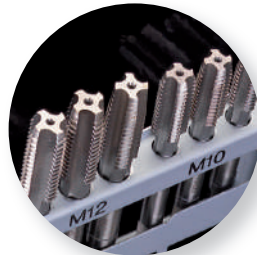





Ref. D656

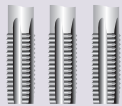



Ref. D657

CONTENIDO

							Nº Piezas	1ª Calidad €	2ª Calidad €
D656	M3 - M4 - M5 - M6 M8 - M10 - M12		2.5 / 3.3 / 4.2 / 5.0 6.8 / 8.5 / 10.2 mm	Nº 1 Nº 2	20 x 5 20 x 7 25 x 9 30 x 11 38 x 14	TC1	43	490,79	434,46
D657* (HSSCo)	M3 - M4 - M5 - M6 M8 - M10 - M12		2.5 / 3.3 / 4.2 / 5.0 6.8 / 8.5 / 10.2 mm	Nº 1 Nº 2	20 x 5 20 x 7 25 x 9 30 x 11 38 x 14	TC1	43	730,62	644,86

\* HSSCo  
5%

**CONJUNTOS DE MACHOS Y COJINETES EN CAJA METÁLICA HSS Y HSSCo**
**M3  
M20**
**M5  
M20**
**HSS**
**HSSCo  
5%**

Ref. D622



Ref. D623

**CONTENIDO**

						Nº Piezas	1ª Calidad €	2ª Calidad €
D622	M3 - M4 - M5 - M6 - M8 - M10 - M12 M14 - M16 - M18 - M20	Nº 1 Nº 3	20 x 5 20 x 7 25 x 9 30 x 11 38 x 14 45 x 18	TC1 TC2	54	751,17	590,19	
D658	M3 - M4 - M5 - M6 - M8 - M10 - M12 M14 - M16 - M18 - M20	Nº 1 Nº 3	20 x 5 20 x 7 25 x 9 30 x 11 38 x 14 45 x 18	-	52	692,01	533,95	
D622i (Izq)	M3 - M4 - M5 - M6 - M8 - M10 - M12 M14 - M16 - M18 - M20	Nº 1 Nº 3	20 x 5 20 x 7 25 x 9 30 x 11 38 x 14 45 x 18	TC1 TC2	54	1.293,58	1.226,46	
D659* (HSSCo)	M3 - M4 - M5 - M6 - M8 - M10 - M12 M14 - M16 - M18 - M20	Nº 1 Nº 3	20 x 5 20 x 7 25 x 9 30 x 11 38 x 14 45 x 18	-	52	1.560,35	1.372,48	
D623	M5 - M6 - M8 - M10 - M12 M14 - M16 - M18 - M20	Nº 1 Nº 3	20 x 7 25 x 9 30 x 11 38 x 14 45 x 18	TC1 TC2	45	787,56	616,58	
D663	M5 - M6 - M7 - M8 - M9 - M10 - M12 M14 - M16 - M18 - M20	Nº 1 Nº 3	20 x 7 25 x 9 30 x 11 38 x 14 45 x 18	-	51	1.049,99	944,44	

\*

**HSSCo  
5%**



**CONJUNTOS DE MACHOS Y COJINETES EN CAJA METÁLICA Y DE MADERA HSS**

**M1  
M10**

**M5  
M12**

**M3  
M24**

**M5  
M30**

**HSS**

Machos y Terrajas

Verde





Ref. D628

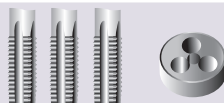

Ref. D626

**CONTENIDO**

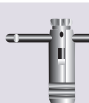
					Nº Piezas	1ª Calidad €	2ª Calidad €
D626	M1 - M1.2 - M1.4 - M1.7 - M2.0 - M2.3 M2.6 - M3 - M3.5 - M4 - M5 - M6 - M8 - M10	Nº 0 Nº 1	16 x 5   20 x 5   20 x 7 25 x 9   30 x 11	TC1	64		982,46
D627	M5 - M6 - M7 - M8 - M9 - M10 - M11 - M12	Nº 1 Nº 2	20 x 7   25 x 9 30 x 11   38 x 14	TC1	39		733,94
D625	M3 - M4 - M5 - M6 - M8 - M10 - M12 - M14 M16 - M18 - M20 - M22 - M24	Nº 1 Nº 4	20 x 5   20 x 7   25 x 9 30 x 11   38 x 14   45 x 18 55 x 22	-	61	1.733,49	1.279,03
D628	M5 - M6 - M8 - M10 - M12 - M14 - M16 M18 - M20 - M22 - M24 - M27 - M30	Nº 1 Nº 3 Nº 5	20 x 7   25 x 9   30 x 11 38 x 14   45 x 18   55 x 22 65 x 25	-	62		2.341,12





**CONJUNTOS DE MACHOS Y COJINETES EN CAJA METÁLICA HSS**
**MF**
**HSS**

Ref. D634

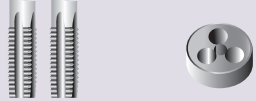

Ref. D636

**CONTENIDO**

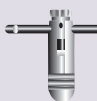
					Nº Piezas	1ª Calidad €	2ª Calidad €
D634	MF 3 x 0.35 - 4 x 0.5 - 5 x 0.5 MF 6 x 0.75 - 8 x 0.75 - 8 x 1.0 MF 10 x 1.0 - 12 x 1.5	Nº 1 Nº 2	20 x 5 25 x 9 30 x 11 38 x 10	TC1	31		673,37
D635	MF 6 x 0.75 - 8 x 0.75 - 8 x 1.0 - 10 x 1.0 MF 12 x 1.0 - 12 x 1.5 - 14 x 1.25 - 14 x 1.5 MF 16 x 1.5 - 18 x 1.5 - 20 x 1.5	Nº 1 Nº 3	20 x 7 25 x 9 30 x 11 38 x 10 45 x 14	-	40	1.098,40	1.044,50
D636	MF 6 x 0.75 - 8 x 0.75 - 8 x 1.0 - 10 x 1.0 MF 12 x 1.0 - 12 x 1.5 - 14 x 1.25 - 14 x 1.5 MF 16 x 1.5 - 18 x 1.5 - 20 x 1.5 - 22 x 1.5 MF 24 x 1.5	Nº 1 Nº 4	20 x 7 25 x 9 30 x 11 38 x 10 45 x 14 55 x 16	-	47	1.506,80	1.393,14

**CONJUNTOS DE MACHOS Y COJINETES EN CAJA METÁLICA HSS**





**BSP  
(GAS)**

**HSS**

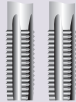

Ref. D638

**CONTENIDO**

						Nº Piezas	1ª Calidad €	2ª Calidad €
D637	G 1/8 - 1/4 - 3/8 - 1/2 - 3/4 - 1"		Nº 1 Nº 3 Nº 5	30 x 11 38 x 10 45 x 14 55 x 16 65 x 18	-	26	1.219,57	985,15
D638	G 1/8 - 1/4 - 3/8 - 1/2 - 5/8 - 3/4 - 7/8 - 1"		Nº 1 Nº 3 Nº 5	30 x 11 38 x 10 45 x 14 55 x 16 65 x 18	-	32	1.655,08	1.444,76
D639	G 1/4 - 3/8 - 1/2 - 3/4 - 1" - 1".1/4 - 1".1/2		Nº 2 Nº 4 Nº 7	38 x 10 45 x 14 55 x 16 65 x 18 75 x 20 90 x 22	-	30	3.053,34	2.575,61





**BSW**

**HSS**

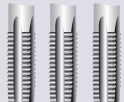

Ref. D640



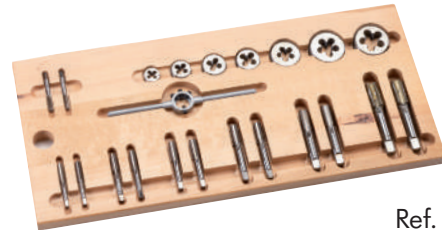

**CONTENIDO**

						Nº Piezas	1ª Calidad €	2ª Calidad €
D640	BSW 1/8 - 3/16 - 1/4 - 5/16 - 3/8 - 7/16 - 1/2		Nº 1 Nº 2	20 x 5 20 x 7 25 x 9 30 x 11 38 x 14	TC1	36	680,35	581,59
D641	BSW 1/4 - 5/16 - 3/8 - 7/16 - 1/2		Nº 1 Nº 2	20 x 7 25 x 9 30 x 11 38 x 14	TC1	27	560,86	472,40
D642	BSW 1/4 - 5/16 - 3/8 - 7/16 - 1/2 - 5/8 - 3/4		Nº 1 Nº 3	20 x 7 25 x 9 30 x 11 38 x 14 45 x 18	-	35	1.003,74	915,87
D643	BSW 1/4 - 5/16 - 3/8 - 7/16 1/2 - 5/8 - 3/4 - 7/8 - 1"		Nº 1 Nº 4	20 x 7 25 x 9 30 x 11 38 x 14 45 x 18 55 x 22	-	44	1.419,51	1.246,27
D646	BSW 1/4 - 5/16 - 3/8 - 7/16 1/2 - 5/8 - 3/4 - 7/8 - 1" - 1".1/8 1".1/4 - 1".3/8 - 1".1/2		Nº 1 Nº 3 Nº 5	20 x 7 25 x 9 30 x 11 38 x 14 45 x 18 55 x 22 65 x 25	-	62		3.787,14

**CONJUNTOS DE MACHOS Y COJINETES EN CAJA METÁLICA HSS**
**BSF**
**HSS**

Ref. D648

**CONTENIDO**

						Nº Piezas	1ª Calidad €	2ª Calidad €
D664	BSF 1/4 - 5/16 - 3/8 - 7/16 - 1/2		Nº 1 Nº 2	20 x 7 25 x 9 30 x 11 38 x 10	TC1	22	627,20	551,68
D648	BSF 1/4 - 5/16 - 3/8 - 7/16 - 1/2 - 5/8 - 3/4		Nº 1 Nº 3	20 x 7 25 x 9 30 x 11 38 x 10 45 x 14	-	28	973,67	915,87
D665	BSF 1/4 - 5/16 - 3/8 - 7/16 1/2 - 5/8 - 3/4 - 7/8 - 1"		Nº 1 Nº 4	20 x 7 25 x 9 30 x 11 38 x 10 45 x 14 55 x 16	-	35	1.652,14	1.453,21

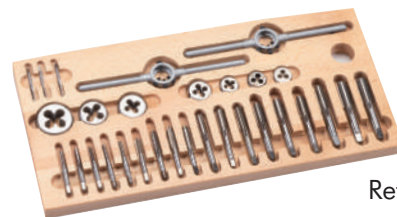
**BSW  
BSF**
**HSS**

Ref. D666

**CONTENIDO**





						Nº Piezas	1ª Calidad €	2ª Calidad €
D666	BSW 1/4 - 5/16 - 3/8 - 7/16 - 1/2 - 5/8 - 3/4 BSF 1/4 - 5/16 - 3/8 - 7/16 - 1/2 - 5/8 - 3/4		Nº 1 Nº 3	20 x 7 25 x 9 30 x 11 38 x 14 45 x 18	-	63	1.866,31	1.641,59

**CONJUNTOS DE MACHOS Y COJINETES EN CAJA METÁLICA HSS**



Ref. D660





**CONTENIDO**

						Nº Piezas	1ª Calidad €	2ª Calidad €
D660	NPT 1/8 - 1/4 - 3/8 - 1/2 - 3/4 - 1"		Nº1 Nº3 Nº5	30 x 11 38 x 14 45 x 18 55 x 22 65 x 25	-	20	1.764,15	1.673,38
D661	NPT 1/8 - 1/4 - 3/8 - 1/2 - 3/4 1" - 1".1/4 - 1".1/2 - 2"		Nº 2 Nº 4 Nº 7	30 x 11 38 x 14 45 x 18 55 x 22 65 x 25 75 x 30 90 x 36 105 X 36	-	29	5.280,96	4.961,44

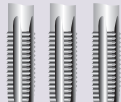

Ref. D650

**CONTENIDO**

						Nº Piezas	1ª Calidad €	2ª Calidad €
D650	UNC 1/4 - 5/16 - 3/8 - 7/16 - 1/2		Nº 1 Nº 2	20 x 7 25 x 9 30 x 11 38 x 14	TC1	27	683,62	613,58
D667	UNC 1/4 - 5/16 - 3/8 - 7/16 - 1/2 - 5/8 - 3/4		Nº 1 Nº 2	20 x 7 25 x 9 30 x 11 38 x 14 45 x 18	-	35	1.101,43	968,80
D654	UNC 1/4 - 5/16 - 3/8 - 7/16 1/2 - 5/8 - 3/4 - 7/8 - 1"		Nº 1 Nº 4	20 x 7 25 x 9 30 x 11 38 x 14 45 x 18 55 x 22	-	44	1.777,26	1.663,29
D668	UNC 1/4 - 5/16 - 3/8 - 7/16 - 1/2 - 5/8 - 3/4 7/8 - 1" - 1.1/8 - 1".1/4 - 1".3/8 - 1".1/2"		Nº 1 Nº 3 Nº 6	20 x 7 25 x 9 30 x 11 38 x 14 45 x 18 55 x 22 65 x 25	-	62	4.160,95	3.659,94





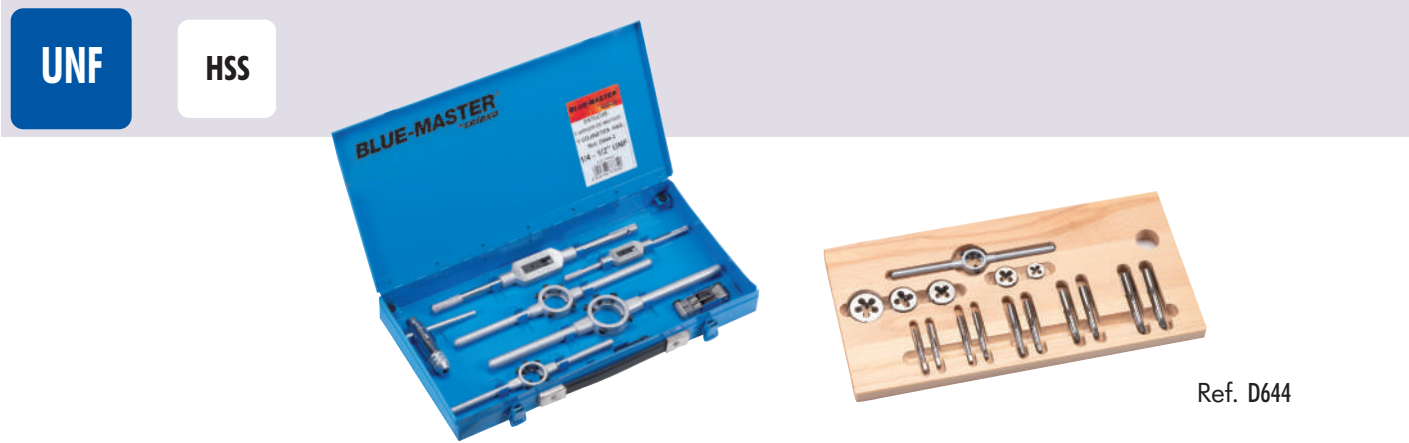

**CONJUNTOS DE MACHOS Y COJINETES EN CAJA METÁLICA HSS**



Ref. D644



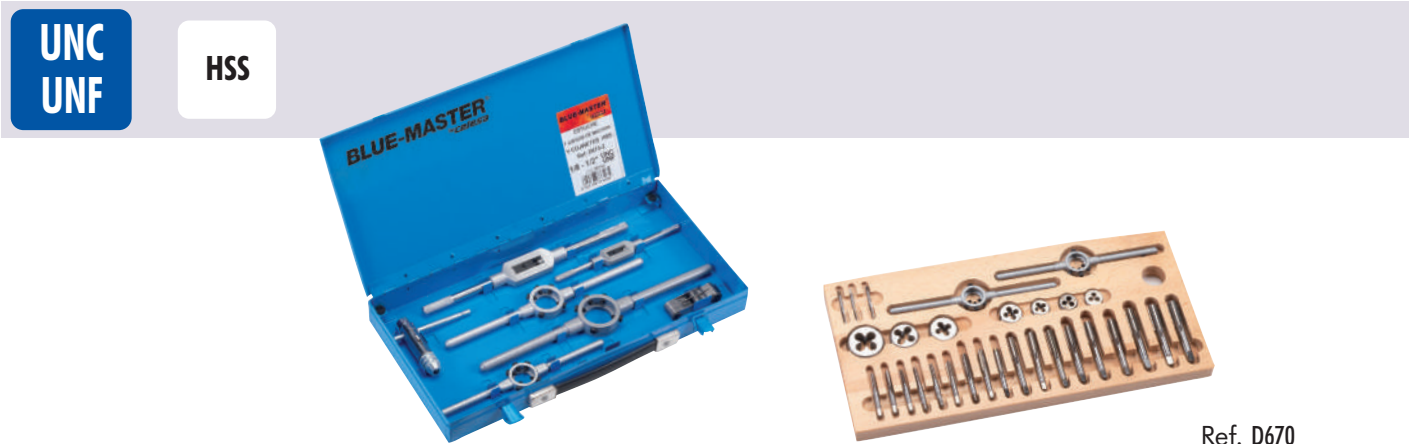

**CONTENIDO**

						Nº Piezas	1ª Calidad €	2ª Calidad €
D644	UNF 1/4 - 5/16 - 3/8 - 7/16 - 1/2		Nº 1 Nº 2	20 x 7 25 x 9 30 x 11 38 x 10		TC1 22	535,68	464,39
D669	UNF 1/4-5/16 -3/8 -7/16 -1/2 -5/8 -3/4		Nº 1 Nº 3	20 x 7 25 x 9 30 x 11 38 x 10 45 x 14		- 28	1.009,64	888,07
D645	UNF 1/4 - 5/16 - 3/8 - 7/16 - 1/2 - 5/8 3/4 - 7/8 - 1"		Nº 1 Nº 4	20 x 7 25 x 9 30 x 11 38 x 10 45 x 14 55 x 16		- 34	1.238,02	1.122,51

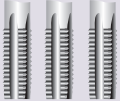

Ref. D670

**CONTENIDO**

						Nº Piezas	1ª Calidad €	2ª Calidad €
D670	UNC 1/4 - 5/16 - 3/8 - 7/16 - 1/2 - 5/8 - 3/4 UNF 1/4 - 5/16 - 3/8 - 7/16 - 1/2 - 5/8 - 3/4		Nº 1 Nº 3	20 x 7 25 x 9 30 x 11 38 x 14 45 x 18		- 35	1.866,31	1.641,59

**JUEGOS DE MACHOS DE MANO HSS Y TiN EN ESTUCHES METÁLICOS**



Ref. JMB0









Ref. JMB2

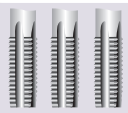

Ref. JMBT2

**CONTENIDO**

					HSS €		TiN* €
JMB2	M3 - M4 - M5 - M6 M8 - M10 - M12	-	-	-	173,42	JMBT2	344,33
JMB0	M3 - M4 - M5 - M6 M8 - M10 - M12	2.5 / 3.3 / 4.2 / 5.0 6.8 / 8.5 / 10.2 mm	-	-	197,82	JMBT0	386,41
JMB1	M3 - M4 - M5 - M6 M8 - M10 - M12	2.5 / 3.3 / 4.2 / 5.0 6.8 / 8.5 / 10.2 mm	Nº 1.1/2	-	212,90	JMBT1	331,12
JMB5	M3 - M4 - M5 - M6 M8 - M10 - M12	2.5 / 3.3 / 4.2 / 5.0 6.8 / 8.5 / 10.2 mm	Nº 1.1/2	TC1	226,13	JMBT5	346,95
JMBI2 (lza)	 M3 - M4 - M5 - M6 M8 - M10 - M12	-	-	-	321,60	JMBIT2	598,17
JMBI0 (lza)	 M3 - M4 - M5 - M6 M8 - M10 - M12	2.5 / 3.3 / 4.2 / 5.0 6.8 / 8.5 / 10.2 mm	-	-	372,56	JMBIT0	648,79
JMBI1 (lza)	 M3 - M4 - M5 - M6 M8 - M10 - M12	2.5 / 3.3 / 4.2 / 5.0 6.8 / 8.5 / 10.2 mm	Nº 1.1/2	-	387,10	JMBIT1	662,24

**MACHOS TERCEROS DE MANO HSS Y TiN EN ESTUCHES METÁLICOS**









Ref. JMB3



Ref. JMB4

**CONTENIDO**

3º					HSS €		TiN* €
JMB3	M3 - M4 - M5 - M6 M8 - M10 - M12	-	-	-	79,61	JMBT3	99,69
JMB4	M3 - M4 - M5 - M6 M8 - M10 - M12	2.5 / 3.3 / 4.2 / 5.0 6.8 / 8.5 / 10.2 mm	-	-	99,08	JMBT4	131,71
JMB7	M3 - M4 - M5 - M6 M8 - M10 - M12	2.5 / 3.3 / 4.2 / 5.0 6.8 / 8.5 / 10.2 mm	Nº 1.1/2	-	113,38	JMBT7	182,69
JMB6	M3 - M4 - M5 - M6 M8 - M10 - M12	2.5 / 3.3 / 4.2 / 5.0 6.8 / 8.5 / 10.2 mm	Nº 1.1/2	TC1	122,77	JMBT6	194,71
JMBI3 (lza)	 M3 - M4 - M5 - M6 M8 - M10 - M12	-	-	-	107,18	JMBIT3	199,38
JMBI4 (lza)	 M3 - M4 - M5 - M6 M8 - M10 - M12	2.5 / 3.3 / 4.2 / 5.0 6.8 / 8.5 / 10.2 mm	-	-	143,63	JMBIT4	264,28



**MACHOS DE MANO HSSCo EN ESTUCHES METÁLICOS**
**HSSCo**  
**5%**

Ref. JMBX0

**CONTENIDO**

INOX	 MOX	 HSSCo			€
JMBX0	M3 - M4 - M5 - M6 M8 - M10 - M12	2.5 / 3.3 / 4.2 / 5.0 6.8 / 8.5 / 10.2 mm	-	-	273,36
JMBX1	M3 - M4 - M5 - M6 M8 - M10 - M12	2.5 / 3.3 / 4.2 / 5.0 6.8 / 8.5 / 10.2 mm	Nº 1.1/2	-	287,70
JMBX2	M3 - M4 - M5 - M6 M8 - M10 - M12	-	-	-	258,49

**CONTENIDO**

1100 N/mm <sup>2</sup>	 MOMD	 HSSCo			€
JMBMD0	M3 - M4 - M5 - M6 M8 - M10 - M12	2.5 / 3.3 / 4.2 / 5.0 6.8 / 8.5 / 10.2 mm	-	-	285,48
JMBMD1	M3 - M4 - M5 - M6 M8 - M10 - M12	2.5 / 3.3 / 4.2 / 5.0 6.8 / 8.5 / 10.2 mm	Nº 1.1/2	-	300,33
JMBMD2	M3 - M4 - M5 - M6 M8 - M10 - M12	-	-	-	272,13

**ESTUCHES DE COJINETES EN CAJAS METÁLICAS HSS**

Ref. C5B3



**CONTENIDO**

		HSS €
C5B3	M3 - M4 - M5 - M6 - M8 - M10 - M12	207,19
C5B3I (Izq)	M3 - M4 - M5 - M6 - M8 - M10 - M12	410,36

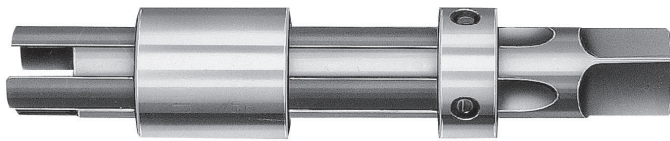

**EXTRACTOR DE MACHOS ROTOS PARA MACHOS DE CANALES RECTOS - NO HELICOIDALES**



**EXTRACTORES SUELTOS**

Ø MACHO A EXTRAER		MACHOS DE MANO	MACHOS DE MÁQUINA	€/ Ud.
BSW UNC	M			EXTRACTOR COMPLETO
--	M3		W10043	39,51
1/8	M3,2		W10053	39,51
--	M3,5		W10063	39,51
5/32	M4		W10083	39,51
3/16	M5		W10103	39,51
--	M5,5	W10124	W10123	39,51
1/4	M6	W10254	W10253	40,67
5/16	M8	W10314	W10313	42,62
--	M9	W10374	W10373	42,21
3/8	M10	W10404	W10373	42,21
7/16	M11	W10434	W10433	44,56
1/2	M12	W10504	W10503	47,65
9/16	M14	W10564	W10563	65,86
5/8	M16	W10624	W10623	71,67
--	M18	W10684	W10753	88,81
3/4	M20	W10754	W10753	88,81
7/8	M22	W10874	W10873	97,17
1"	M25	W11004	W11003	108,36

**VARILLA REPUESTO**

MACHOS DE MANO	MACHOS DE MÁQUINA	€/ Ud.
		VARILLA EXTRA
	W12043	2,10
	W12053	2,10
	W12063	2,10
	W12083	2,10
	W12103	3,14
	W12123	3,14
	W12253	3,82
W12314	W12313	4,32
W12374		4,32
W12404	W12373	4,45
W12434	W12433	4,53
W12504	W12503	5,69
W12564	W12563	6,35
W12624	W12623	8,12
W12684		8,12
W12754	W12753	8,59
W12874	W12873	11,14
W13004	W13003	18,53

**3 SIMPLES PASOS PARA EXTRAER MACHOS DE ROSCAR ROTOS DE CANALES RECTOS**

Sacar toda la viruta del macho roto. Introducir las varillas del extractor en los canales del macho roto con firmeza hasta el fondo.

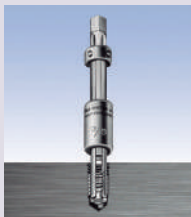

Empujar el soporte hacia abajo, hasta tocar el macho roto. Deslice el casquillo hacia abajo, hasta tocar la zona de trabajo.



Aplicar al cuadradillo del extractor un gira-machos. Gire a izquierdas unas cuantas veces hasta soltarlo y entonces saque el macho roto.

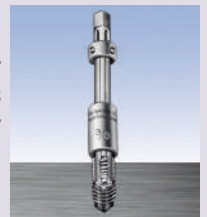

**JUEGOS DE EXTRACTORES PARA MACHOS ROTOS (CANALES RECTOS)**



Nº CANALES	MEDIDAS INCLUIDAS PARA MACHOS DE MÁQUINA Y DE MANO: 3 y 4 CANALES	
W180013	3 M5- M6- M8- M10- M11- M12	273,90
W180014	4 3/16 - 1/4 - 5/16 - 3/8 - 7/16 - 1/12	
W180023	3 M6- M8 -M10- M11- M12- M16	308,16
W180024	4 1/4 - 5/16 - 3/8 - 7/16 - 1/12 - 5/8	
W180153	3 M3- M3,2- M3,5- M4-M5- M5,50- M6- M8	862,01
W180154	4 M9- M10- M12- M16- M18- M22- M25	

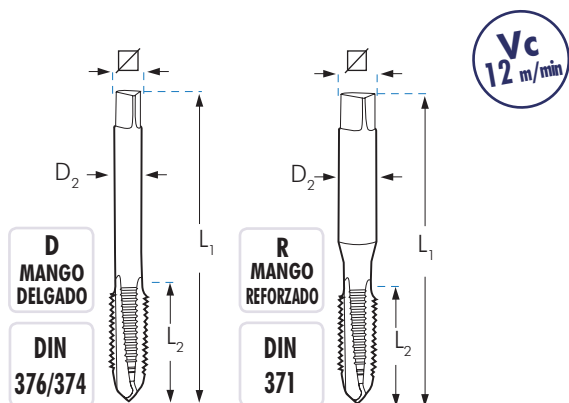
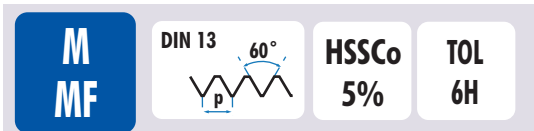

**MACHOS PARA ROSCAR A MÁQUINA HSSCo**

Icono	D	L1	L2	D2	R	L1	L2	D2	M1D	M2D	M3D	M4D	M1R	M2R	M3R	M4R
													FORMA C	FORMA B	FORMA C	FORMA B
									€	€	€	€	€	€	€	€
	M 1x0,25	0,75			R			40 x 6 x 2,5 x 2,1					36,14			
	M 1,1x0,25	0,85			R			40 x 6 x 2,5 x 2,1					35,16			
	M 1,2x0,25	0,95			R			40 x 6 x 2,5 x 2,1					32,12			
	M 1,4x0,30	1,10			R			40 x 7 x 2,5 x 2,1					32,12			
	M 1,6x0,35	1,25			R			40 x 8 x 2,5 x 2,1					31,54			
	M 1,7x0,35	1,35			R			40 x 8 x 2,5 x 2,1					30,38			
	M 1,8x0,35	1,45			R			40 x 8 x 2,5 x 2,1					29,63			
	M 2x0,40	1,60			R			40 x 9 x 2,8 x 2,1					13,77	15,54	18,00	18,34
	M 2,2x0,45	1,75			R			40 x 9 x 2,8 x 2,1					15,41			
	M 2,3x0,40	1,90			R			40 x 9 x 2,8 x 2,1					14,20			
	M 2,5x0,45	2,05			R			50 x 9 x 2,8 x 2,1					13,77	15,54	25,31	18,34
	M 2,6x0,45	2,10			R			50 x 9 x 2,8 x 2,1					14,30	15,81		30,49
	M 3x0,50	2,50			R			56 x 11 x 3,5 x 2,7	9,81	10,63	14,00	12,74	9,63*	9,96	14,36	13,06
	M 3x0,60	2,40			R			56 x 11 x 3,5 x 2,7					16,80	18,67		24,66
	M 3,5x0,60	2,90			R			56 x 12 x 4,0 x 3,0					13,25	14,05	18,15	17,03
	M 3,5x0,75	2,75			R			56 x 12 x 4,0 x 3,0					18,16			
	M 4x0,50	3,50			R			63 x 13 x 4,5 x 3,4	20,53	22,78		24,77	19,77	22,41		25,95
	M 4x0,70	3,30			R			63 x 13 x 4,5 x 3,4	9,98	10,74	15,27	12,63	10,37*	10,43	14,04	13,07
	M 4x0,75	3,25			R			63 x 13 x 4,5 x 3,4					15,03	16,36		
	M 4x0,80	3,20			R			63 x 13 x 4,5 x 3,4					79,82			
	M 4,5x0,50	4,00			R			70 x 14 x 6,0 x 4,9						26,08		
	M 4,5x0,75	3,75			R			70 x 14 x 6,0 x 4,9					17,90	20,09		
	M 5x0,50	4,50			R			70 x 14 x 6,0 x 4,9	21,14	23,41		25,05	20,36	23,03		27,68
	M 5x0,75	4,50			R			70 x 14 x 6,0 x 4,9					18,26	21,83		27,50
	M 5x0,80	4,20			R			70 x 16 x 6,0 x 4,9	9,98	10,69	14,64	12,12	9,90*	10,45	13,46	12,53
	M 5x0,90	4,10			R			70 x 15 x 6,0 x 4,9					15,89	20,84		
	M 5x1,00	4,00			R			70 x 16 x 3,5 x 2,7					42,55			
	M 5,5x0,90	4,60			R			80 x 17 x 6,0 x 4,9					42,55			
	M 6x0,50	5,50			R			80 x 17 x 6,0 x 4,9	25,04	30,93		40,14	26,66			
	M 6x0,75	5,25			R			80 x 13 x 6,0 x 4,9	16,49	19,25		23,11	17,27	20,50		24,62
	M 6x1,00	5,00			R			80 x 17 x 6,0 x 4,9	11,38	11,72	14,77	13,29	11,27*	11,46	14,77	13,75

\* Disponibles también con rosca izquierda con 100% de recargo sobre los precios tarifados en rosca derecha



**MACHOS PARA ROSCAR A MÁQUINA HSSCo**

**M MF** **DIN 13** **60°** **HSSCo** **5%** **TOL** **6H** **D MANGO DELGADO** **DIN 376/374** **Vc** **12 m/min** **R MANGO REFORZADO** **DIN 371**

M	L1 x L2 x D2 x mm	R	M1D		M2D		M3D		M4D		MTR		M2R		M3R		M4R	
			FORMA C	FORMA B	FORMA C	FORMA B	15°	35°	FORMA C	FORMA B	15°	35°	FORMA C	FORMA B	15°	35°	FORMA C	FORMA B
			€	€	€	€	€	€	€	€	€	€	€	€	€	€	€	€
M 6x1,25	4,75	R	80 x 17 x 6,0 x 4,9								41,83							
M 7x0,75	6,25	D	80 x 13 x 5,5 x 4,3	22,01	23,74				30,14									
<b>M 7x1,00</b>	<b>6,00</b>	R	80 x 17 x 7,0 x 5,5	14,24	16,45	18,43	18,24				13,97*	16,30	18,43	18,24				
M 8x0,50	7,50	D	80 x 13 x 6 x 4,9	27,77														
M 8x0,75	7,25	D	80 x 13 x 6 x 4,9	20,13	24,67				32,61									
M 8x1,00	7,00	D	90 x 20 x 6 x 4,9	16,45	18,89	23,45	21,52											
<b>M 8x1,25</b>	<b>6,80</b>	R	90 x 20 x 8 x 6,2	12,78	13,09	17,76	15,52				12,73*	12,85	17,50	15,55				
M 8x1,50	6,50	D	90 x 20 x 6 x 4,9	84,36														
M 9x1,00	8,00	D	90 x 20 x 7 x 5,5	24,89	27,57				29,30									
<b>M 9x1,25</b>	<b>7,80</b>	R	90 x 20 x 9 x 7,0	20,73	21,78	26,38	25,78				20,91	21,58	27,08	27,27				
M 10x0,50	9,50	D	90 x 20 x 7 x 5,5	83,58														
M 10x0,75	9,25	D	90 x 16 x 7 x 5,5	31,90	33,13				40,34									
M 10x1,00	9,00	D	90 x 16 x 7 x 5,5	18,22	20,99	27,69	25,45											
M 10x1,25	8,80	D	100 x 22 x 7 x 5,5	20,86	25,10	30,18	27,74											
<b>M 10x1,50</b>	<b>8,50</b>	R	100 x 22 x 10 x 8,0	14,30	16,14	20,92	18,42				14,43*	15,83	19,54	18,42				
M 11x0,75	10,25	D	90 x 20 x 8 x 6,2															
M 11x1,00	10,00	D	90 x 20 x 8 x 6,2	32,66	34,96	88,37	80,42											
M 11x1,25	9,75	D	100 x 22 x 8 x 6,2	32,38	35,98	88,37	71,78											
<b>M 11x1,50</b>	<b>9,50</b>	D	100 x 22 x 8 x 6,2	26,26	29,67	64,44	58,61											
M 12x0,75	11,25	D	100 x 22 x 9 x 7,0	49,59														
M 12x1,00	11,00	D	100 x 22 x 9 x 7,0	24,78	28,36	34,17	32,60											
M 12x1,25	10,75	D	100 x 22 x 9 x 7,0	25,08	27,86	32,71	31,22											
M 12x1,50	10,50	D	100 x 22 x 9 x 7,0	22,42*	24,85	31,46	30,02											
<b>M 12x1,75</b>	<b>10,20</b>	D	100 x 24 x 9 x 7,0	17,22*	19,96	27,52	23,72											
M 13x0,75	12,25	D	100 x 22 x 11 x 9,0	86,55														
M 13x1,00	12,00	D	100 x 22 x 11 x 9,0	45,83	51,90													
M 13x1,25	11,75	D	100 x 22 x 11 x 9,0	45,83	51,90													
M 13x1,50	11,50	D	100 x 22 x 11 x 9,0	45,83	51,90													
<b>M 13x1,75</b>	<b>11,25</b>	D	100 x 22 x 11 x 9,0	45,51	51,90													
M 14x0,75	13,25	D	100 x 22 x 11 x 9,0	86,55														
M 14x1,00	13,00	D	100 x 22 x 11 x 9,0	39,89	43,88	52,68	52,23											
M 14x1,25	12,80	D	100 x 22 x 11 x 9,0	33,95	37,05	48,31	44,40											
M 14x1,50	12,50	D	100 x 22 x 11 x 9,0	26,70*	29,42	38,10	35,02											
<b>M 14x2,00</b>	<b>12,00</b>	D	110 x 26 x 11 x 9,0	26,52*	29,47	34,16	34,15											
M 15x1,00	14,00	D	100 x 22 x 12 x 9,0	50,73	55,65		70,87											
M 15x1,25	13,75	D	100 x 22 x 12 x 9,0	56,31	60,97													
M 15x1,50	13,50	D	100 x 22 x 12 x 9,0	45,00	49,53	131,13	106,37											
<b>M 15x2,00</b>	<b>13,00</b>	D	110 x 27 x 12 x 9,0	55,09	60,63													
M 16x1,00	15,00	D	100 x 22 x 12 x 9,0	47,81	52,57	73,74	71,60											
M 16x1,25	14,75	D	100 x 22 x 12 x 9,0	53,01	58,29	82,00	79,42											
M 16x1,50	14,50	D	100 x 22 x 12 x 9,0	31,57*	36,79	47,48	43,64											
<b>M 16x2,00</b>	<b>14,00</b>	D	110 x 27 x 12 x 9,0	31,22*	34,47	41,27	41,26											
M 17x1,00	16,00	D	100 x 22 x 12 x 9,0	98,58														
M 17x1,25	15,75	D	100 x 22 x 12 x 9,0	98,58														
M 17x1,50	15,50	D	100 x 22 x 12 x 9,0	98,58														
M 18x1,00	17,00	D	110 x 25 x 14 x 11,0	53,54	58,84		87,62											
M 18x1,25	16,75	D	110 x 25 x 14 x 11,0	68,78														
M 18x1,50	16,50	D	110 x 25 x 14 x 11,0	41,80*	46,00	58,34	54,77											
M 18x2,00	16,00	D	125 x 30 x 14 x 11,0	58,99	65,98	115,44	103,04											

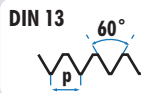
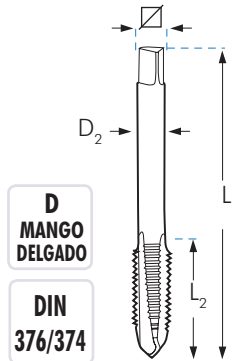
\* Disponibles también con rosca izquierda con 100% de recargo sobre los precios tarifados en rosca derecha

**MACHOS PARA ROSCAR A MÁQUINA HSSCo**
**M  
MF**

**HSSCo  
5%**
**TOL  
6H**
**D  
MANGO  
DELGADO**
**DIN  
376/374**
**Vc  
12  
m/min**

**D  
MANGO  
DELGADO**
**DIN  
376/374**

		L <sub>1</sub> x L <sub>2</sub> x D <sub>2</sub> x  mm	M1D	M2D	M3D	M4D	
			FORMA C	FORMA B	15°	35°	
			€	€	€	€	
M	18x2,50	15,50	D 125 x 30 x 14 x 11,0	44,91*	49,11	55,56	53,50
M	19x1,00	18,00	D 110 x 22 x 14 x 11,0	129,53			
M	19x1,25	17,75	D 110 x 25 x 14 x 11,0	133,20			
M	19x1,50	17,50	D 110 x 25 x 14 x 11,0	127,13			
M	19x2,00	17,00	D 110 x 25 x 14 x 11,0				
M	20x1,00	19,00	D 125 x 25 x 16 x 12,0	70,69	78,49		93,58
M	20x1,25	18,75	D 125 x 25 x 16 x 12,0	129,53			
M	20x1,50	18,50	D 125 x 25 x 16 x 12,0	47,34*	52,03	65,57	62,57
M	20x2,00	18,00	D 140 x 32 x 16 x 12,0	62,04	68,22		83,48
M	20x2,50	17,50	D 140 x 32 x 16 x 12,0	47,81*	53,01	59,29	59,30
M	21x1,00	20,00	D 125 x 25 x 16 x 12,0	188,07			
M	21x1,25	19,75	D 125 x 25 x 16 x 12,0	188,07			
M	21x1,50	19,50	D 125 x 25 x 16 x 12,0	179,60			
M	22x1,00	21,00	D 125 x 25 x 18 x 14,5	79,23	87,15		120,59
M	22x1,25	20,75	D 125 x 25 x 18 x 14,5	129,53			
M	22x1,50	20,50	D 125 x 25 x 18 x 14,5	56,98	62,69	71,93	65,30
M	22x2,00	20,00	D 140 x 32 x 18 x 14,5	79,23	87,15		120,59
M	22x2,50	19,50	D 140 x 32 x 18 x 14,5	57,86*	63,63	72,88	69,59
M	23x1,00	22,00	D 125 x 25 x 18 x 14,5	182,84			
M	23x1,50	21,50	D 125 x 25 x 18 x 14,5	182,84			
M	24x1,00	23,00	D 140 x 25 x 18 x 14,5	86,34	108,55		127,42
M	24x1,25	22,75	D 140 x 25 x 18 x 14,5	188,07			
M	24x1,50	22,50	D 140 x 28 x 18 x 14,5	70,09	77,05	96,14	88,36
M	24x2,00	22,00	D 140 x 28 x 18 x 14,5	89,42*	97,42		115,30
M	24x3,00	21,00	D 160 x 34 x 18 x 14,5	69,26*	75,80	87,83	84,59
M	25x1,00	24,00	D 140 x 28 x 18 x 14,5	173,47			
M	25x1,25	23,75	D 140 x 28 x 18 x 14,5	274,11			
M	25x1,50	23,50	D 140 x 28 x 18 x 14,5	109,04	119,61		
M	25x2,00	23,00	D 140 x 28 x 18 x 14,5	243,27	267,61		
M	26x1,00	25,00	D 140 x 28 x 18 x 14,5	134,68			
M	26x1,50	24,50	D 140 x 28 x 18 x 14,5	94,51	99,07	180,10	158,37
M	26x2,00	24,00	D 140 x 28 x 18 x 14,5	243,27	267,61		111,04
M	27x1,00	26,00	D 140 x 28 x 20 x 16,0	120,62	155,75		
M	27x1,50	25,50	D 140 x 28 x 20 x 16,0	103,19	113,30	261,74	236,01
M	27x2,00	25,00	D 140 x 28 x 20 x 16,0	127,64*	135,06		

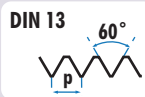
\* Disponibles también con rosca izquierda con 100% de recargo sobre los precios tarifados en rosca derecha

**MACHOS PARA ROSCAR A MÁQUINA HSSCo**



**HSSCo**  
5%

**TOL**  
6H

**D**  
**MANGO**  
**DELGADO**

**DIN**  
**376/374**



			L1 x L2 x D2 x mm	M1D	M2D	M3D	M4D
				FORMA C	FORMA B	15°	35°
				€	€	€	€
<b>M 27x3,00</b>	<b>24,00</b>	D	160 x 36 x 20 x 16	86,46*	94,80	108,08	104,08
M 28x1,00	27,00	D	140 x 28 x 20 x 16	243,27			
M 28x1,50	26,50	D	140 x 28 x 20 x 16	103,19	113,30	136,31	123,06
M 28x2,00	26,00	D	140 x 28 x 20 x 16	130,47	147,36	160,64	157,96
M 30x1,00	29,00	D	150 x 28 x 22 x 18	132,00	158,17		184,41
M 30x1,50	28,50	D	150 x 28 x 22 x 18	107,56	118,36	147,82	135,84
M 30x2,00	28,00	D	150 x 28 x 22 x 18	133,14*	146,44		202,64
M 30x3,00	27,00	D	150 x 28 x 22 x 18				
<b>M 30x3,50</b>	<b>26,50</b>	D	180 x 40 x 22 x 18	110,79*	121,81	138,52	133,38
M 32x1,00	31,00	D	150 x 28 x 22 x 18	324,38	344,43		
M 32x1,50	30,50	D	150 x 28 x 22 x 18	136,10	149,43	182,11	
M 32x2,00	30,00	D	150 x 28 x 22 x 18	173,32	265,39		
M 33x1,00	32,00	D	160 x 30 x 25 x 20	298,75			
M 33x1,50	31,50	D	160 x 30 x 25 x 20	153,34	162,63		196,17
M 33x2,00	31,00	D	160 x 30 x 25 x 20	251,32	276,37		324,87
<b>M 33x3,50</b>	<b>29,50</b>	D	180 x 40 x 25 x 20	133,14*	153,20		176,10
M 34x1,50	32,50	D	170 x 30 x 28 x 22	176,99	187,49		
M 34x2,00	32,00	D	160 x 30 x 28 x 22	372,21			
M 35x1,50	33,50	D	170 x 30 x 28 x 22	180,11	198,10		224,52
M 35x2,00	33,00	D	170 x 30 x 28 x 22	343,47	378,12		
M 36x1,50	34,50	D	170 x 30 x 28 x 22	170,44	194,42		243,90
M 36x2,00	34,00	D	170 x 30 x 28 x 22	230,20	253,22		
M 36x3,00	33,00	D	200 x 50 x 28 x 22	264,11	290,48		353,00
<b>M 36x4,00</b>	<b>32,00</b>	D	200 x 50 x 28 x 22	176,36*	187,20	225,35	215,62
M 38x1,50	36,50	D	170 x 30 x 28 x 22	181,69	204,72		
M 38x2,00	36,00	D	170 x 32 x 28 x 22	386,19	424,83		
M 39x1,50	37,50	D	170 x 32 x 32 x 24	285,51			
M 39x2,00	37,00	D	170 x 32 x 32 x 24	285,51			
M 39x3,00	36,00	D	200 x 47 x 32 x 24	372,86			
<b>M 39x4,00</b>	<b>35,00</b>	D	200 x 50 x 32 x 24	217,27	239,00		
M 40x1,50	38,50	D	170 x 30 x 32 x 24	237,57	261,49		
M 40x2,00	38,00	D	170 x 30 x 32 x 24	286,26			
M 40x3,00	37,00	D	200 x 47 x 32 x 24	280,67	334,86		
M 42x1,50	40,50	D	170 x 30 x 32 x 24	250,13	268,10		
M 42x2,00	40,00	D	170 x 30 x 32 x 24	327,48			
M 42x3,00	39,00	D	200 x 45 x 32 x 24	327,48	415,00		
<b>M 42x4,50</b>	<b>37,50</b>	D	200 x 56 x 32 x 24	279,38	307,24		
M 45x1,50	43,50	D	180 x 32 x 36 x 29	298,75	328,59		
M 45x2,00	43,00	D	180 x 32 x 36 x 29	379,19			
M 45x3,00	42,00	D	200 x 47 x 36 x 29	379,19			
<b>M 45x4,50</b>	<b>40,50</b>	D	220 x 58 x 36 x 29	305,18	335,69		
M 48x1,50	46,50	D	190 x 32 x 36 x 29	305,18			
M 48x2,00	46,00	D	190 x 32 x 36 x 29	475,82			
M 48x3,00	45,00	D	220 x 52 x 36 x 29	459,51			
<b>M 48x5,00</b>	<b>43,00</b>	D	250 x 65 x 36 x 29	375,29	412,79		
M 50x1,50	48,50	D	190 x 32 x 36 x 29	356,91			
M 52x1,50	50,50	D	190 x 32 x 40 x 32	361,34			
M 52x2,00	50,00	D	190 x 32 x 40 x 32	571,82			
M 52x3,00	49,00	D	225 x 50 x 40 x 32	587,67			
<b>M 52x5,00</b>	<b>47,00</b>	D	250 x 65 x 40 x 32	384,34	475,55		

\* Disponibles también con rosca izquierda con 100% de recargo sobre los precios tarifados en rosca derecha

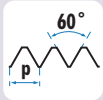
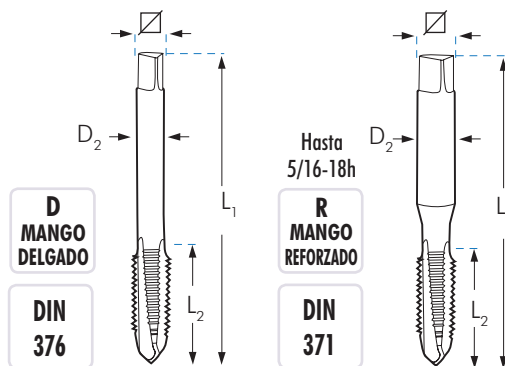

**MACHOS PARA ROSCAR A MÁQUINA HSSCo**
**UNC**

**HSSCo**  
**5%**
**TOL**  
**2B**
**Vc**  
**12 m/min**

	D1 mm		L1 x L2 x D2 x $\nabla$ mm	M1R	M2R	M3R	M4R
				FORMA C €	FORMA B €	15° €	35° €
UNC nº 1-64h	1,85	1,50	R 40 x 8 x 2,5 x 2,1				
UNC nº 2-56h	2,18	1,80	R 45 x 9 x 2,8 x 2,1				
UNC nº 3-48h	2,51	2,10	R 50 x 9 x 2,8 x 2,1				
UNC nº 4-40h	2,84	2,25	R 56 x 11 x 3,5 x 2,7	21,99	26,39		30,11
UNC nº 5-40h	3,17	2,60	R 56 x 11 x 3,5 x 2,7	21,99	26,39		30,11
UNC nº 6-32h	3,50	2,75	R 56 x 12 x 4,0 x 3,0	20,93	25,15		28,67
UNC nº 8-32h	4,17	3,50	R 63 x 13 x 4,5 x 3,4	20,93	25,15		28,67
UNC nº 10-24h	4,83	3,90	R 70 x 15 x 6,0 x 4,9	21,99	26,39		30,11
UNC nº 12-24h	5,49	4,50	R 80 x 16 x 6,0 x 4,9	23,07	26,39		28,91
UNC 1/4-20h	6,35	5,10	R 80 x 17 x 7,0 x 5,5	20,55	22,42		25,86
UNC 5/16-18h	7,94	6,60	R 90 x 20 x 8,0 x 6,2	23,26	25,65		29,20

<b>MANGO DELGADO</b>				M1D	M2D	M3D	M4D
UNC 3/8-16h	9,52	8,00	D 100 x 22 x 7,0 x 5,5	26,53	29,09		32,69
UNC 7/16-14h	11,11	9,40	D 100 x 22 x 8,0 x 6,2	36,50	36,63		45,81
UNC 1/2-13h	12,70	10,75	D 110 x 24 x 9,0 x 7,0	39,61	43,89		50,10
UNC 9/16-12h	14,28	12,20	D 110 x 26 x 11,0 x 9,0	54,45	59,79		68,02
UNC 5/8-11h	15,87	13,50	D 110 x 27 x 12,0 x 9,0	52,90	58,23		66,15
UNC 3/4-10h	19,05	16,50	D 125 x 30 x 14,0 x 11,0	70,04	77,00		87,61
UNC 7/8-9h	22,22	19,50	D 140 x 32 x 18,0 x 14,5	92,17	101,25		137,09
UNC 1"-8h	25,40	22,25	D 160 x 36 x 18,0 x 14,5	121,78	133,03		171,97
UNC 1.1/8-7h	28,57	25,00	D 180 x 40 x 22,0 x 18,0	159,07			200,97
UNC 1.1/4-7h	31,75	28,00	D 180 x 40 x 22,0 x 18,0	195,00			257,09
UNC 1.3/8-6h	34,92	30,75	D 200 x 50 x 28,0 x 22,0	290,86			
UNC 1.1/2-6h	38,10	34,00	D 200 x 50 x 32,0 x 24,0	330,31			
UNC 1.3/4-5h	44,45	39,00	D 220 x 58 x 36,0 x 29,0				
UNC 2"-4,5h	50,80	45,00	D 250 x 65 x 40,0 x 32,0				

MACHOS PARA ROSCAR A MÁQUINA HSSCo

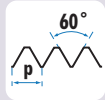
UNF



HSSCo  
5%

TOL  
2B

Vc  
12 m/min

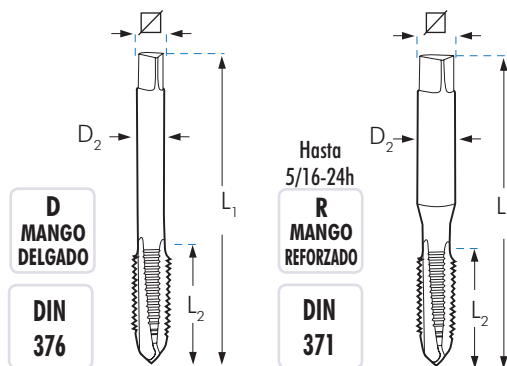

UNF nº	D1 mm	D2 mm	L1 x L2 x D2 x $\nabla$ mm	M1R	M2R	M3R	M4R
				FORMA C	FORMA B	15°	35°
				€	€	€	€
UNF nº 1-72h	1,85	1,50	R 40 x 8 x 2,5 x 2,1				
UNF nº 2-64h	2,18	1,85	R 45 x 9 x 2,8 x 2,1				
UNF nº 3-56h	2,51	2,15	R 50 x 9 x 2,8 x 2,1				
UNF nº 4-48h	2,84	2,35	R 56 x 11 x 3,5 x 2,7	23,23	25,29		31,74
UNF nº 5-44h	3,17	2,70	R 56 x 11 x 3,5 x 2,7	23,23	25,29		31,74
UNF nº 6-40h	3,50	2,95	R 56 x 12 x 4,0 x 3,0	22,22	26,61		31,50
UNF nº 8-36h	4,17	3,50	R 63 x 13 x 4,5 x 3,4	22,22	26,61		31,50
UNF nº 10-32h	4,83	4,10	R 70 x 15 x 6,0 x 4,9	22,22	26,61		31,50
UNF nº 12-28h	5,49	4,60	R 80 x 16 x 6,0 x 4,9	23,23	27,84		31,74
UNF 1/4-28h	6,35	5,50	R 80 x 17 x 7,0 x 5,5	18,76	20,10		23,45
UNF 5/16-24h	7,94	6,90	R 90 x 20 x 8,0 x 6,2	20,98	23,13		27,04

UNF	MANGO DELGADO	D1 mm	D2 mm	D	L1 x L2 x D2 x $\nabla$ mm	M1D	M2D	M3D	M4D
UNF 3/8-24h		9,52	8,50	D	90 x 16 x 7,0 x 5,5	22,97	26,57		32,35
UNF 7/16-20h		11,11	9,90	D	100 x 22 x 8,0 x 6,2	28,34	32,84		41,45
UNF 1/2-20h		12,70	11,50	D	100 x 22 x 9,0 x 7,0	30,18	34,93		44,11
UNF 9/16-18h		14,29	12,90	D	100 x 22 x 11,0 x 9,0	37,08	42,93		54,61
UNF 5/8-18h		15,87	14,50	D	100 x 22 x 12,0 x 9,0	41,74	48,28		61,02
UNF 3/4-16h		19,05	17,50	D	110 x 25 x 14,0 x 11,0	53,40	61,84		78,06
UNF 7/8-14h		22,22	20,40	D	125 x 25 x 18,0 x 14,5	67,16	84,01		119,39
UNF 1"-12h		25,40	23,25	D	140 x 28 x 18,0 x 14,5	101,08	110,06		146,98
UNS 1"-14h		25,40	23,60	D	140 x 28 x 18,0 x 14,5	106,13	113,23		146,98
UNF 1.1/8-12h		28,57	26,50	D	150 x 28 x 22,0 x 18,0	154,02			
UNF 1.1/4-12h		31,75	29,50	D	150 x 28 x 22,0 x 18,0	194,63			
UNF 1.3/8-12h		34,92	33,00	D	170 x 30 x 28,0 x 22,0				
UNF 1.1/2-12h		38,10	36,00	D	170 x 30 x 32,0 x 24,0	326,66			
UNF 2"-12h		50,80	36,00	D	200 x 70 x 35,5 x 28,0				

## MACHOS PARA ROSCAR A MÁQUINA HSSCo

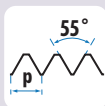
BSP  
(GAS)HSSCo  
5%TOL  
ISO 228

INOX

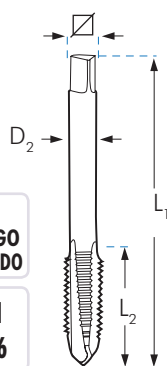
Vc  
12 m/minVc  
6 m/minD  
MANGO  
DELGADODIN  
5156

Forma	D1 mm	D2 mm	L1 x L2 x D2 x $\square$ mm	M1D	M2D	M3D	M4D	M2DX	M4DX
				FORMA C	FORMA B	15°	35°	FORMA B	35°
				€	€	€	€	€	€
G 1/8-28h.	9,728	8,80	D 90 x 16 x 7 x 5,5	28,09*	32,09	34,38	34,06	49,98	49,47
G 1/4-19h.	13,157	11,80	D 100 x 22 x 11 x 9,0	38,96*	42,89	49,37	48,91	67,34	72,07
G 3/8-19h.	16,662	15,25	D 100 x 22 x 12 x 9,0	46,64*	51,32	58,97	58,41	79,89	84,71
G 1/2-14h.	20,955	19,00	D 125 x 25 x 16 x 12,0	58,95*	64,86	74,38	73,67	98,92	106,91
G 5/8-14h.	22,911	21,00	D 125 x 25 x 18 x 14,5	73,46*	80,57	92,60	91,74		
G 3/4-14h.	26,441	24,50	D 140 x 28 x 20 x 16,0	92,27	101,54	116,42	115,32	142,91	164,89
G 7/8-14h.	30,201	28,25	D 150 x 28 x 22 x 18,0	124,02	136,46	156,57	155,11		
G 1"-11h.	33,249	30,75	D 160 x 30 x 25 x 20,0	143,21	157,50	178,75	177,10		
G 1.1/8-11h.	37,897	35,50	D 170 x 30 x 28 x 22,0	228,68	260,89		286,54		
G 1.1/4-11h.	41,910	39,50	D 170 x 30 x 32 x 24,0	268,33	295,28		326,89		
G 1.3/8-11h.	44,323	42,00	D 180 x 32 x 36 x 29,0	335,57			454,05		
G 1.1/2-11h.	47,803	45,25	D 190 x 32 x 36 x 29,0	427,87	596,46		590,97		
G 1.3/4-11h.	53,746	51,25	D 190 x 32 x 40 x 32,0	508,57	615,36				
G 2"-11h.	59,614	57,00	D 220 x 36 x 45 x 35,0	648,63	675,25				

\* Disponibles también con rosca izquierda con 100% de recargo sobre los precios tarifados en rosca derecha

BSF

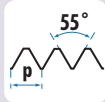
HSSCo  
5%TOL  
ISO 228Vc  
12 m/minD  
MANGO  
DELGADODIN  
5156

Forma	D1 mm	D2 mm	L1 x L2 x D2 x $\square$ mm	M1D	M2D	M3D	M4D
				FORMA C	FORMA B	15°	35°
				€	€	€	€
BSF 3/16-32h.	4,762	4,00	D 70 x 16 x 3,5 x 2,7	67,21			
BSF 1/4-26h.	6,350	5,20	D 80 x 17 x 4,5 x 3,4	29,41			
BSF 5/16-22h.	7,938	6,60	D 90 x 20 x 6,0 x 4,9	34,92			
BSF 3/8-20h.	9,525	8,10	D 100 x 22 x 7,0 x 5,5	36,72			
BSF 7/16-18h.	11,113	9,50	D 100 x 22 x 8,0 x 6,2	49,48			
BSF 1/2-16h.	12,700	11,00	D 110 x 24 x 9,0 x 7,0	56,00			
BSF 9/16-16h.	14,287	12,50	D 110 x 25 x 11,0 x 9,0	59,26			
BSF 5/8-14h.	15,876	14,00	D 110 x 27 x 12,0 x 9,0	78,99			
BSF 3/4-12h.	19,051	16,50	D 125 x 30 x 14,0 x 11,0	93,50			
BSF 7/8-11h.	22,226	19,50	D 140 x 32 x 18,0 x 14,5	129,96			
BSF 1"-10h.	25,400	22,50	D 160 x 36 x 18,0 x 14,5	151,06			

MACHOS PARA ROSCAR A MÁQUINA HSSCo

BSW

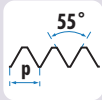

HSSCo  
5%

TOL  
Clase 2

Vc  
12 m/min

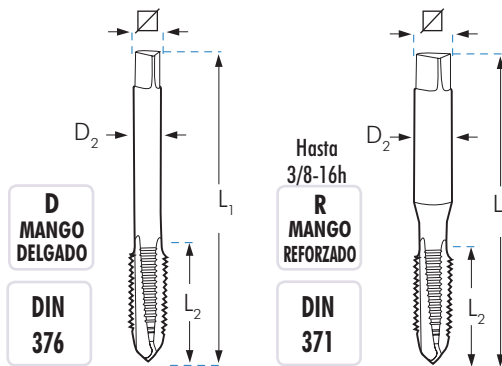

Icono	D1 mm	D	L1 x L2 x D2 x $\nabla$ mm	M1R	M2R	M3R	M4R	
				FORMA C	FORMA B	15°	35°	
				€	€	€	€	
	W 1/16-60h.	1,59	1,15	R 40 x 8 x 2,5 x 2,1				
	W 3/32-48h.	2,38	1,80	R 50 x 9 x 2,8 x 2,1	19,52	21,79		
	W 1/8-40h.	3,17	2,55	R 56 x 11 x 3,5 x 2,7	16,29*	18,00	22,23	20,44
	W 5/32-32h.	3,97	3,10	R 63 x 13 x 4,5 x 3,4	16,29	18,00	22,23	20,44
	W 3/16-24h.	4,76	3,60	R 70 x 15 x 6,0 x 4,9	18,07	18,00	22,23	20,44
	W 7/32-24h.	5,56	4,40	R 80 x 16 x 6,0 x 4,9	24,73	27,34		
	W 1/4-20h.	6,35	5,10	R 80 x 17 x 7,0 x 5,5	17,40	20,44	25,23	24,99
	W 5/16-18h.	7,94	6,50	R 90 x 20 x 8,0 x 6,2	20,40	25,79	29,44	28,11
	W 3/8-16h.	9,52	7,90	R 100 x 22 x 10,0 x 8,0	21,83	28,50	32,72	31,23

MANGO DELGADO				M1D	M2D	M3D	M4D
W	D1	D	D				
W 7/16-14h.	11,11	9,25	D 100 x 22 x 8,0 x 6,2	31,75	31,38	41,25	39,72
W 1/2-12h.	12,70	10,50	D 110 x 24 x 9,0 x 7,0	30,45	32,73	39,53	38,06
W 9/16-12h.	14,29	12,00	D 110 x 26 x 11,0 x 9,0	43,65	45,33	56,68	54,58
W 5/8-11h.	15,87	13,40	D 110 x 27 x 12,0 x 9,0	41,33	42,83	53,60	51,61
W 11/16-11h.	17,46	15,25	D 110 x 27 x 12,0 x 9,0				
W 3/4-10h.	19,05	16,50	D 125 x 30 x 14,0 x 11,0	55,30	57,40	71,81	69,15
W 7/8-9h.	22,22	19,25	D 140 x 32 x 18,0 x 14,5	74,92	77,69	97,20	93,61
W 1"-8h.	25,40	21,75	D 160 x 36 x 18,0 x 14,5	94,15	97,64	121,98	117,46
W 1.1/8-7h.	28,57	24,75	D 180 x 40 x 22,0 x 18,0	122,09	145,50	174,96	
W 1.1/4-7h.	31,75	27,75	D 180 x 40 x 22,0 x 18,0	177,37	211,41		
W 1.3/8-6h.	34,92	30,50	D 200 x 50 x 28,0 x 22,0	291,53	347,17		
W 1.1/2-6h.	38,10	33,50	D 200 x 50 x 32,0 x 24,0	316,44	377,18		
W 1.5/8-5h.	41,27	46,50	D 220 x 65 x 32,0 x 24,0	441,68	526,48		
W 1.3/4-5h.	44,45	39,00	D 220 x 58 x 36,0 x 29,0	494,80	567,98		
W 1.7/8-4,5h.	47,62	42,00	D 250 x 75 x 36,0 x 29,0	548,57	629,66		
W 2"-4,5h.	50,80	44,50	D 250 x 65 x 40,0 x 32,0	708,17			
W 2.1/4-4h.	57,15	50,00					
W 2.1/2-4h.	63,50	56,50					
W 2.3/4-3,5h.	69,85	62,00					
W 3"-3,5h.	76,20	68,00					

\* Disponibles también con rosca izquierda con 100% de recargo sobre los precios tarifados en rosca derecha

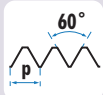
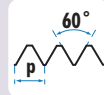
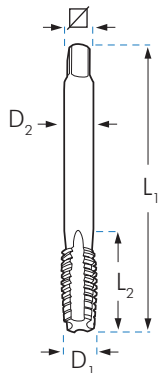
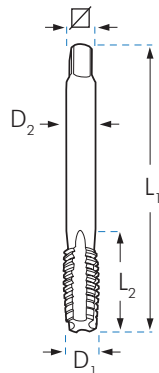

**MACHOS PARA ROSCAR A MÁQUINA HSSCo**
**UNJC**

**HSSCo**  
**5%**
**TOL**  
**3B**
**UNJF**

**HSSCo**  
**5%**
**TOL**  
**3B**
**Vc**  
**12 m/min**

**Vc**  
**12 m/min**

Icon	D1 mm	D2 mm	R	L1 x L2 x D2 x $\nabla$ mm	MIR
					FORMA C
					€
UNJC nº 4-40h	2,84	2,25	R	56 x 11 x 3,5 x 2,7	33,71
UNJC nº 5-40h	3,17	2,60	R	56 x 11 x 3,5 x 2,7	33,71
UNJC nº 6-32h	3,50	2,75	R	56 x 12 x 4,0 x 3,0	32,07
UNJC nº 8-32h	4,17	3,50	R	63 x 13 x 4,5 x 3,4	32,07
UNJC nº 10-24h	4,83	3,90	R	70 x 15 x 6,0 x 4,9	33,71
UNJC nº 12-24h	5,49	4,50	R	80 x 16 x 6,0 x 4,9	35,36
UNJC 1/4-20h	6,35	5,10	R	80 x 17 x 7,0 x 5,5	31,45
UNJC 5/16-18h	7,94	6,60	R	90 x 20 x 8,0 x 6,2	35,59
UNJC 3/8-16h	9,52	8,00	R	100 x 22 x 8,0 x 6,2	40,58

Icon	D1 mm	D2 mm	R	L1 x L2 x D2 x $\nabla$ mm	MIR
					FORMA C
					€
UNJF nº 4-48h	2,84	2,35	R	56 x 11 x 3,5 x 2,7	36,97
UNJF nº 5-44h	3,17	2,70	R	56 x 11 x 3,5 x 2,7	36,97
UNJF nº 6-40h	3,50	2,95	R	56 x 12 x 4,0 x 3,0	35,36
UNJF nº 8-36h	4,17	3,50	R	63 x 13 x 4,5 x 3,4	35,36
UNJF nº 10-32h	4,83	4,10	R	70 x 15 x 6,0 x 4,9	35,36
UNJF nº 12-28h	5,49	4,60	R	80 x 16 x 6,0 x 4,9	36,97
UNJF 1/4-28h	6,35	5,50	R	80 x 17 x 7,0 x 5,5	28,71
UNJF 5/16-24h	7,94	6,90	R	90 x 20 x 8,0 x 6,2	32,10
UNJF 3/8-24h	9,52	8,50	R	90 x 16 x 7,0 x 6,2	35,15

MANGO DELGADO PASOS NORMALES				MID
UNJC 7/16-14h	11,11	9,40	D 110 x 24 x 9,0 x 7,0	55,95
UNJC 1/2-13h	12,70	10,75	D 110 x 26 x 11,0 x 9,0	60,74
UNJC 9/16-12h	14,28	12,20	D 110 x 27 x 12,0 x 9,0	83,47
UNJC 5/8-11h	15,87	13,50	D 110 x 27 x 12,0 x 9,0	86,10
UNJC 3/4-10h	19,05	16,50	D 125 x 30 x 14,0 x 11,0	107,37
UNJC 7/8-9h	22,22	19,50	D 140 x 32 x 18,0 x 14,5	141,27
UNJC 1"-8h	25,40	22,25	D 160 x 36 x 18,0 x 14,5	186,65

MANGO DELGADO PASOS NORMALES				MID
UNJF 7/16-20h	11,11	9,90	D 100 x 22 x 8,0 x 6,2	48,27
UNJF 1/2-20h	12,70	11,50	D 100 x 22 x 9,0 x 7,0	51,40
UNJF 9/16-18h	14,29	12,90	D 100 x 22 x 11,0 x 9,0	63,15
UNJF 5/8-18h	15,87	14,50	D 100 x 22 x 12,0 x 9,0	71,10
UNJF 3/4-16h	19,05	17,50	D 110 x 25 x 14,0 x 11,0	90,96
UNJF 7/8-14h	22,22	20,40	D 125 x 25 x 18,0 x 14,5	114,39
UNJF 1"-12h	25,40	23,25	D 140 x 28 x 18,0 x 14,5	127,53

MACHOS PARA ROSCAR A MÁQUINA HSSCo

**BSPB** DIN 2999 55° HSSCo 5% DIN 374 FORMA C

**BSPT** BS21 ISO7/1 55° HSSCo 5% DIN 5156 FORMA C

ROSCA CILÍNDRICA INGLESA PARA TUBO

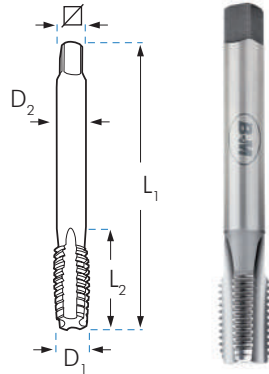

ROSCA CÓNICA INGLESA PARA TUBO

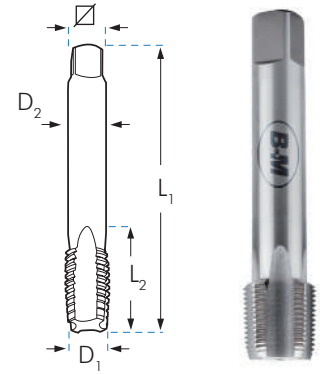

	D1 mm	L1 x L2 x D2 x ∅ mm	MTD	€
Rp 1/16-28h.	7,72	D 90 x 16 x 6 x 4,9		
Rp 1/8-28h.	9,73	D 90 x 16 x 7 x 5,5		43,84
Rp 1/4-19h.	13,16	D 100 x 22 x 11 x 9,0		60,55
Rp 3/8-19h.	16,66	D 100 x 22 x 12 x 9,0		72,50
Rp 1/2-14h.	20,95	D 125 x 25 x 16 x 12,0		91,63
Rp 3/4-14h.	26,44	D 140 x 28 x 20 x 16,0		143,49
Rp 1"-11h.	33,25	D 160 x 30 x 25 x 20,0		222,62
Rp 1.1/4-11h.	41,91	D 170 x 30 x 32 x 24,0		
Rp 1.1/2-11h.	46,80	D 190 x 32 x 36 x 29,0		
Rp 2"-11h.	59,61	D 220 x 36 x 45 x 35,0		

	D1 mm		L1 x L2 x D2 x ∅ mm	MTD	€
Rc 1/16-28h.	7,72		D 90 x 14 x 6 x 4		
Rc 1/8-28h.	9,73	8,30	D 90 x 15 x 7 x 5		44,86
Rc 1/4-19h.	13,16	11,00	D 100 x 19 x 11 x 9		64,50
Rc 3/8-19h.	16,66	14,50	D 100 x 21 x 12 x 9		89,65
Rc 1/2-14h.	20,95	18,10	D 125 x 26 x 16 x 12		124,56
Rc 5/8-14h.	22,91	21,00	D 140 x 36 x 18 x 19		200,94
Rc 3/4-14h.	26,44	23,50	D 140 x 28 x 20 x 16		194,27
Rc 7/8-14h.	30,20	28,25	D 160 x 36 x 22 x 18		338,07
Rc 1"-11h.	33,25	29,60	D 160 x 33 x 25 x 20		278,44

**NPS (M)** ANSI B 1.20.1 60° HSSCo 5% DIN 374 FORMA C

**NPT** ANSI B 1.20.1 60° HSSCo 5% DIN 374 FORMA C

ROSCA CILÍNDRICA AMERICANA PARA TUBO

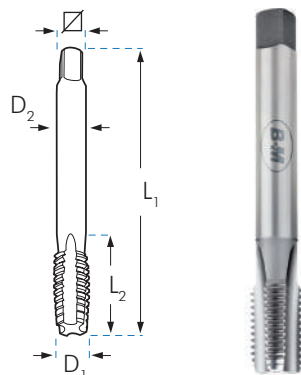

ROSCA CÓNICA AMERICANA PARA TUBO

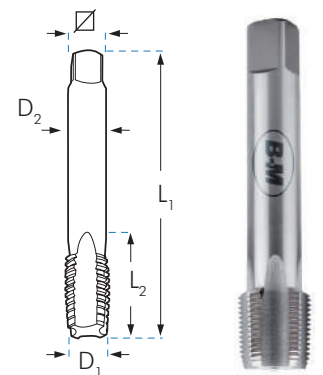

	D1 mm		L1 x L2 x D2 x ∅ mm	MTD	€
NPS 1/8-27h.	10,20	8,90	D 90 x 16 x 7 x 5,5		112,92
NPS 1/4-18h.	13,60	11,70	D 100 x 22 x 11 x 9,0		161,61
NPS 3/8-18h.	17,00	15,00	D 100 x 22 x 12 x 9,0		221,61
NPS 1/2-14h.	21,20	18,60	D 125 x 25 x 16 x 12,0		303,89
NPS 3/4-14h.	26,55	24,00	D 140 x 28 x 20 x 16,0		449,24
NPS 1"-11,5 h.	33,20	30,00	D 160 x 30 x 25 x 20,0		580,95
NPS 1.1/4-11,5h.	41,60		D 170 x 30 x 32 x 24,0		
NPS 1.1/2-11,5h.	47,68		D 190 x 32 x 36 x 29,0		
NPS 2"-11,5h.	59,71		D 220 x 36 x 45 x 35,0		

	D1 mm		L1 x L2 x D2 x ∅ mm	MTD	€
NPT 1/16-27h.	7,89	6,2	D 90 x 14 x 6 x 5		39,28
NPT 1/8-27h.	10,24	8,5	D 90 x 15 x 8 x 6		39,28
NPT 1/4-18h.	13,62	11,0	D 100 x 19 x 11 x 9		53,06
NPT 3/8-18h.	17,05	14,5	D 100 x 21 x 12 x 9		68,20
NPT 1/2-14h.	21,22	17,8	D 125 x 26 x 16 x 12		88,73
NPT 3/4-14h.	26,57	23,0	D 140 x 28 x 20 x 16		137,47
NPT 1"-11,5h.	33,23	29,0	D 160 x 33 x 25 x 20		178,67
NPT 1.1/4-11,5h.	41,98	37,5	D 170 x 36 x 32 x 24		243,95
NPT 1.1/2-11,5h.	48,05	44,0	D 190 x 37 x 36 x 29		384,13
NPT 2"-11,5h.	60,09	56,0	D 220 x 41 x 45 x 35		602,54

## MACHOS PARA ROSCAR A MÁQUINA HSSCo

NPSF

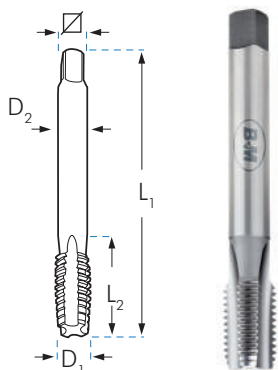
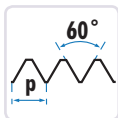
HSSCo  
5%DIN  
374FORMA  
CROSCA PARA TUBO  
AMERICANA CILÍNDRICA

NPTF

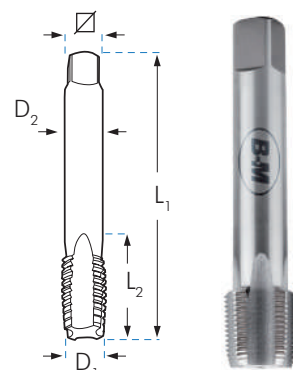
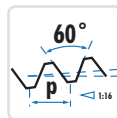
HSSCo  
5%DIN  
374FORMA  
CROSCA PARA TUBO  
AMERICANA CÓNICA ESTANCA

		MID			
		D1 mm		L1 x L2 x D2 x $\nabla$ mm	€
NPSF	1/8-27h.	10,05	8,75	D 90 x 16 x 7 x 5,5	141,44
NPSF	1/4-18h.	13,33	11,30	D 100 x 22 x 11 x 9,0	194,95
NPSF	3/8-18h.	16,78	14,70	D 100 x 22 x 12 x 9,0	277,34
NPSF	1/2-14h.	20,87	18,20	D 125 x 25 x 16 x 12,0	345,86
NPSF	3/4-14h.	26,23	23,50	D 140 x 28 x 20 x 16,0	566,04
NPSF	1"-11,5h.	32,81	29,50	D 160 x 30 x 25 x 20,0	

		MID			
		D1 mm		L1 x L2 x D2 x $\nabla$ mm	€
NPTF	1/16-27h.	7,87	6,20	D 90 x 14 x 12,0 x 6	
NPTF	1/8-27h.	10,22	8,50	D 90 x 15 x 12,0 x 7	95,56
NPTF	1/4-18h.	13,58	11,00	D 100 x 21 x 17,5 x 11	134,06
NPTF	3/8-18h.	17,02	14,50	D 110 x 21 x 17,6 x 12	172,23
NPTF	1/2-14h.	21,21	17,80	D 140 x 27 x 22,8 x 16	224,21
NPTF	3/4-14h.	26,56	23,00	D 140 x 27 x 23,0 x 20	347,34

MF

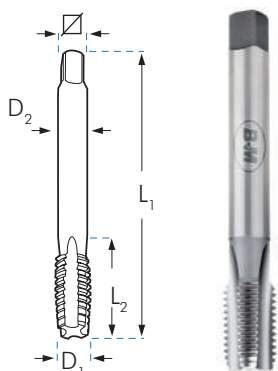
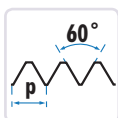
HSSCo  
5%TOL  
6HFORMA  
CDIN  
374ROSCA MÉTRICA FINA PARA  
TUBO DE CONDUCCIÓN  
ELÉCTRICA EN 60423

PG

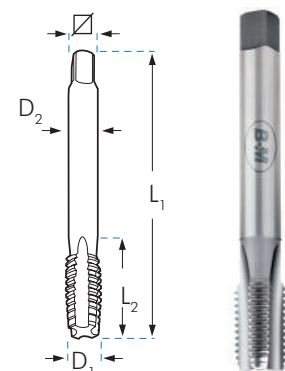
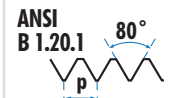
HSSCo  
5%DIN  
40430FORMA  
CROSCA PARA TUBO  
DE CONDUCCIÓN  
ELÉCTRICA

		MID			
		D1 mm		L1 x L2 x D2 x $\nabla$ mm	€
MF	12 x 1,50	12	10,5	D 100 x 22 x 9 x 7,0	22,42
MF	16 x 1,50	16	14,5	D 100 x 22 x 12 x 9,0	31,57
MF	20 x 1,50	20	18,5	D 125 x 25 x 16 x 12,0	47,34
MF	25 x 1,50	25	23,5	D 140 x 28 x 18 x 14,5	109,04
MF	32 x 1,50	32	30,5	D 150 x 28 x 22 x 18,0	136,10
MF	40 x 1,50	40	38,5	D 170 x 30 x 32 x 24,0	237,57
MF	50 x 1,50	50	48,5	D 190 x 32 x 36 x 29,0	356,91
MF	63 x 1,50	63	61,5	D 275 x 36 x 50 x 39,0	

		MID			
		D1 mm		L1 x L2 x D2 x $\nabla$ mm	€
PG	7 - 20h.	12,5	11,50	D 100 x 22 x 9 x 7,0	41,93
PG	9 - 18h.	15,2	14,00	D 100 x 22 x 12 x 9,0	58,07
PG	11 - 18h.	18,6	17,25	D 110 x 25 x 14 x 11,0	75,56
PG	13,5 - 18h.	20,4	19,00	D 125 x 25 x 16 x 12,0	84,85
PG	16 - 18h.	22,5	21,25	D 125 x 25 x 18 x 14,5	99,86
PG	21 - 16h.	28,3	27,00	D 150 x 28 x 22 x 18,0	158,53
PG	29 - 16h.	37,0	35,50	D 170 x 30 x 28 x 22,0	268,00
PG	36 - 16h.	47,0	45,50	D 190 x 32 x 36 x 29,0	435,24
PG	42 - 16h.	54,0	52,50	D 190 x 32 x 40 x 32,0	691,25
PG	48 - 16h.	59,3	58,00	D 220 x 36 x 45 x 35,0	842,69

**MACHOS PARA ROSCAR A MÁQUINA HSSCo**

**UNx8**    **HSSCo**    **DIN**    **FORMA**    **TOL**  
5%    374    C    2B

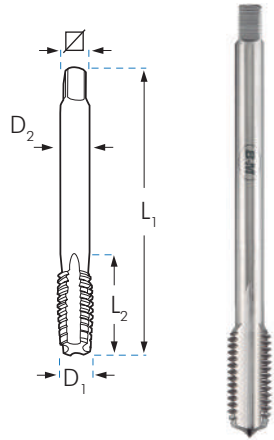
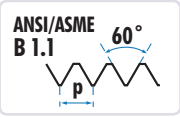

**UNEF**    **HSSCo**    **DIN**    **TOL**  
5%    374    2B

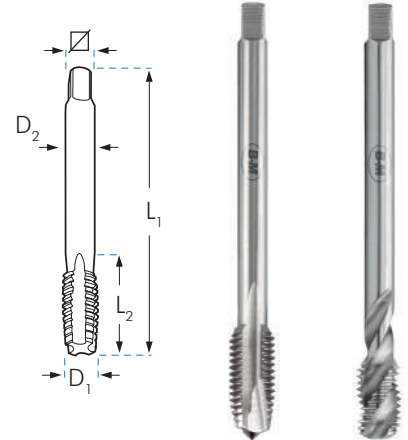
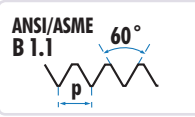

				M1D	
		D <sub>2</sub> mm	L <sub>1</sub> x L <sub>2</sub> x		€
UN 1" 1/8-8h.		25,40	22	180 x 45 x 18	208,46
UN 1" 1/4-8h.		28,50	22	180 x 48 x 18	268,94
UN 1" 3/8-8h.		31,75	28	200 x 56 x 22	305,09
UN 1" 1/2-8h.		35,00	32	200 x 58 x 22	388,16
UN 1" 5/8-8h.		38,10	32	200 x 65 x 24	454,06
UN 1" 3/4-8h.		41,25	36	200 x 50 x 29	553,12
UN 1" 7/8-8h.		44,45	36	225 x 53 x 29	638,03
UN 2"-8h.		47,63	40	225 x 50 x 32	651,92

					M2D	M4D
		D <sub>2</sub> mm	L <sub>1</sub> x L <sub>2</sub> x		FORMA B €	35° €
UNEF 1/4-32h.		5,55	7,0	R 82 x 16 x 5,4	86,25	96,93
UNEF 5/16-32h.		7,15	8,4	R 85 x 21 x 6,1	95,04	106,79
UNEF 3/8-32h.		8,70	7,0	D 95 x 22 x 5,4	95,09	106,84
UNEF 7/16-28h.		10,20	8,0	D 100 x 22 x 6,2	126,22	141,82
UNEF 1/2-28h.		11,80	9,0	D 100 x 22 x 7,0	132,95	149,37
UNEF 9/16-24h.		13,20	12,0	D 100 x 24 x 9,0	166,56	187,14
UNEF 5/8-24h.		14,80	12,0	D 100 x 24 x 9,0	189,53	212,96
UNEF 3/4-20h.		17,80	14,0	D 110 x 27 x 11,0	246,51	276,99
UNEF 7/8-20h.		20,95	18,0	D 125 x 26 x 14,5	264,97	283,90
UNEF 1"-20h.		24,20	18,0	D 140 x 28 x 14,5	405,50	455,62

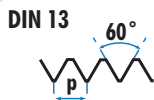
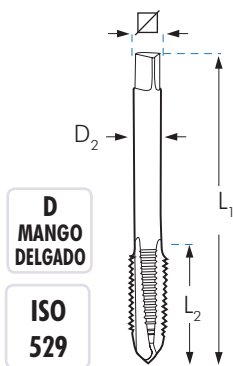
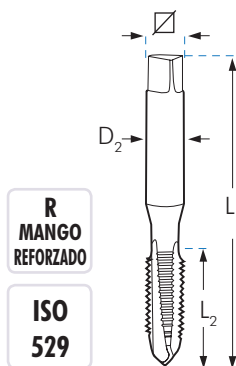

**MACHOS MÁQUINA MÉTRICA NORMA ISO 529**
**M**  
**MF**

**HSSCo**  
**5%**
**ISO**  
**529**
**TOL**  
**6H**

**D**  
**MANGO**  
**DELGADO**  
**ISO**  
**529**

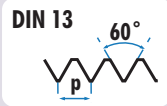
**R**  
**MANGO**  
**REFORZADO**  
**ISO**  
**529**

		L <sub>1</sub> x L <sub>2</sub> x D <sub>2</sub> x  mm	M1RISO	M2RISO	M4RISO	M5RISO
			FORMA C	FORMA B	 35°	DIENTE ALTERNO <b>AI</b>
			€	€	€	€
M 3x0,50	2,50	R 48 x 11 x 3,15 x 2,50	7,08	7,37	8,88	10,56
M 4x0,70	3,30	R 53 x 13 x 4,00 x 3,15	7,08	7,37	8,88	10,56
M 5x0,80	4,20	R 58 x 16 x 5,00 x 4,00	7,08	7,37	8,88	10,56
M 6x1,00	5,00	R 66 x 19 x 6,30 x 5,00	7,08	7,37	9,07	10,56
M 7x1,00	6,00	R 66 x 19 x 7,10 x 5,60		10,49	12,04	
M 8x1,00	7,00	D 69 x 19 x 8,00 x 6,30		14,47	14,08	
M 8x1,25	6,75	R 72 x 22 x 8,00 x 6,30	9,45	9,84	10,18	11,54
M 9x1,25	7,75	R 76 x 20 x 10,00 x 8,00		15,66	17,88	
M 10x1,00	9,00	D 76 x 20 x 10,00 x 8,00		16,60	18,13	
M 10x1,25	8,80	D 76 x 20 x 10,00 x 8,00		19,84	19,76	
M 10x1,50	8,50	R 80 x 24 x 10,00 x 8,00	12,02	12,52	13,12	14,56
<b>MANGO DELGADO</b>			M1DISO	M2DISO	M4DISO	M5DISO
M 12x1,00	11,00	D 84 x 24 x 9,00 x 7,10		22,87	23,43	
M 12x1,25	10,75	D 84 x 24 x 9,00 x 7,10		22,46	22,44	
M 12x1,50	10,50	D 89 x 29 x 9,00 x 7,10		20,04	21,58	
M 12x1,75	10,20	D 89 x 29 x 9,00 x 7,10	15,45	16,09	17,05	21,78
M 14x1,00	13,00	D 90 x 25 x 11,20 x 9,00		28,64	35,62	
M 14x1,25	12,80	D 90 x 25 x 11,20 x 9,00		24,19	30,28	
M 14x1,50	12,50	D 95 x 30 x 12,50 x 9,00		21,25	23,88	
M 14x2,00	12,00	D 95 x 30 x 11,20 x 9,00	18,47	19,24	23,29	
M 16x1,00	15,00	D 95 x 25 x 12,50 x 10,00		36,44	46,89	
M 16x1,25	14,75	D 102 x 32 x 12,50 x 10,00		40,40	52,00	
M 16x1,50	14,50	D 102 x 32 x 14,00 x 10,00		25,50	28,58	
M 16x2,00	14,00	D 102 x 32 x 12,50 x 10,00	22,94	23,89	27,02	
M 18x1,50	16,50	D 104 x 29 x 14,00 x 11,20		33,70	46,04	
M 18x2,50	15,50	D 112 x 37 x 14,00 x 11,20	34,53	35,97	44,97	
M 20x1,50	18,50	D 104 x 29 x 14,00 x 11,20		43,36	53,03	
M 20x2,50	17,50	D 112 x 37 x 14,00 x 11,20	38,60	40,21	50,26	
M 22x2,50	19,50	D 118 x 38 x 16,00 x 12,50	44,63	46,49	58,12	
M 24x3,00	21,00	D 130 x 45 x 18,00 x 14,00	50,43	52,53	65,66	
M 27x3,00	24,00	D 135 x 45 x 20,00 x 16,00	62,09	64,68	80,85	
M 30x3,50	26,50	D 138 x 48 x 20,00 x 16,00	92,25	96,10	120,12	

MACHOS MÁQUINA CORTOS DIN 352



HSS

HSSCo  
5%

DIN  
352

TOL  
6H

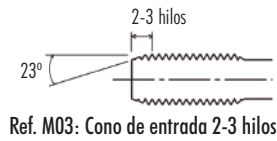

Ref. M03: Cono de entrada 2-3 hilos

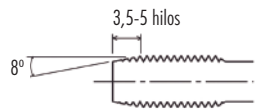

Ref. M02AT: Cono de entrada 3,5-5 hilos

D  
MANGO  
DELGADO

DIN  
352

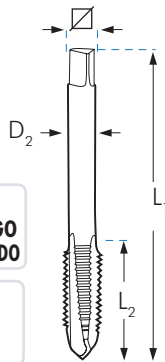

Icono	D	L1 x L2 x D2 x $\square$ mm	M03	M02AT	M03X	M02DIN	M04DIN
			FORMA C	ALTURA TERMINADA	INOX	FORMA B	35°
			HSS	HSS	HSSCo	HSS	HSS
			€	€	€	€	€
M 3x0,50	2,50	D 40 x 11 x 3,50 x 2,70	6,37	8,60	10,47	8,11	9,77
M 4x0,70	3,30	D 45 x 13 x 4,50 x 3,40	6,36	8,59	10,47	8,11	9,77
M 5x0,80	4,20	D 50 x 16 x 6,00 x 4,90	6,81	9,19	10,90	8,11	9,77
M 6x1,00	5,00	D 50 x 19 x 6,00 x 4,90	6,81	9,19	10,87	8,11	9,98
M 7x1,00	6,00	D 50 x 19 x 6,00 x 4,90	8,29				
M 8x1,00	7,00	D 56 x 18 x 6,00 x 4,90	11,47				
M 8x1,25	6,75	D 56 x 22 x 6,00 x 4,90	8,28	11,18	12,65	10,83	12,10
M 9x1,25	7,75	D 63 x 18 x 7,00 x 5,50	13,57				
M 10x1,00	9,00	D 63 x 18 x 7,00 x 5,50	12,28				
M 10x1,25	8,80	D 70 x 24 x 7,00 x 5,50	12,45				
M 10x1,50	8,50	D 70 x 24 x 7,00 x 5,50	10,21	13,78	16,27	13,77	15,25
M 12x1,00	11,00	D 70 x 20 x 9,00 x 7,00	21,78				
M 12x1,25	10,75	D 70 x 20 x 9,00 x 7,00	21,71				
M 12x1,50	10,50	D 70 x 20 x 9,00 x 7,00	18,50				
M 12x1,75	10,20	D 75 x 29 x 9,00 x 7,00	14,37	19,40	23,30	17,70	19,85
M 14x1,00	13,00	D 70 x 20 x 11,00 x 9,00	33,03				
M 14x1,25	12,80	D 70 x 20 x 11,00 x 9,00	26,51				
M 14x1,50	12,50	D 70 x 20 x 11,00 x 9,00	20,62				
M 14x2,00	12,00	D 80 x 30 x 11,00 x 9,00	15,90	21,46	25,81	21,16	25,62
M 16x1,00	15,00	D 70 x 20 x 12,00 x 9,00	45,02				
M 16x1,25	14,75	D 70 x 20 x 12,00 x 9,00	47,39				
M 16x1,50	14,50	D 70 x 20 x 12,00 x 9,00	25,65				
M 16x2,00	14,00	D 80 x 32 x 12,00 x 9,00	22,55		35,37	26,28	29,72
M 18x1,50	16,50	D 80 x 22 x 14,00 x 11,00	33,80				
M 18x2,50	15,50	D 95 x 40 x 14,00 x 11,00	29,76		48,30	39,57	49,47
M 20x1,50	18,50	D 80 x 22 x 16,00 x 12,00	42,33				
M 20x2,50	17,50	D 95 x 40 x 16,00 x 12,00	33,39		53,61	44,23	55,28
M 22x2,50	19,50	D 100 x 40 x 18,00 x 14,50	44,84			51,14	63,93
M 24x3,00	21,00	D 110 x 50 x 18,00 x 14,50	53,05			57,78	72,22
M 27x3,00	24,00	D 110 x 50 x 20,00 x 16,00	67,63			74,58	81,87
M 30x3,50	26,50	D 125 x 50 x 22,00 x 18,00	87,04			95,82	104,92

MACHOS DE MÁQUINA Y COJINETES SERIE *Plus* Y *Super Plus*

Machos y Terrajas

Rosa

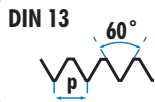

TOL  
6H

PARA TRABAJOS DE ALTA PRODUCCIÓN  
FABRICADOS EN ACERO SINTERIZADO

DIN  
22568

TOL  
6g



*Plus*    *Plus TiN*    *Plus LUBE*    *Super Plus ALTiN*

				<i>Plus</i>		<i>Plus TiN</i>		<i>Plus LUBE</i>		<i>Super Plus ALTiN</i>		C5P	
		M2RP	M4RP	M2RT	M4RT	M2RHL	M4RHL	M2RSP	M4RSP				
CALIDAD		★★	★★	★★★	★★★	★★★★	★★★★	★★★★	★★★★	★★★★	★★★★		
MATERIAL		HSS PM	HSS PM	HSSCo 5%	HSSCo 5%	HSS PM	HSS PM	HSS V3	HSS V3			HSS	
ACABADO		BRILLANTE	BRILLANTE	TiN	TiN	HARD LUBE	HARD LUBE	ALTiN	ALTiN			BRILLANTE	
ÁNGULO DE HÉLICE		FORMA B	FORMA B 35°	FORMA B	FORMA B 35°	FORMA B	FORMA B 35°	FORMA B	FORMA B 41°				
		L1 x L2 x D2 x $\nabla$ mm		€	€	€	€	€	€	€	€	Ø x L3 mm	€
M 3x0,50	2,50 R	56 x 11 x 3,5 x 2,7	13,97	17,27	18,81	20,78	25,65	27,27	32,38	33,59	25 x 9	26,68	
M 4x0,70	3,30 R	63 x 13 x 4,5 x 3,4	14,27	17,27	19,11	21,68	25,57	27,65	32,38	33,59	25 x 9	26,68	
M 5x0,80	4,20 R	70 x 16 x 6,0 x 4,9	14,27	16,55	19,11	21,56	24,99	27,65	34,19	34,83	25 x 9	26,68	
M 6x1,00	5,00 R	80 x 17 x 6,0 x 4,9	15,70	18,17	22,00	23,82	28,08	29,26	34,19	34,83	25 x 9	26,68	
M 8x1,00	7,00 D	90 x 20 x 6,0 x 4,9	22,40	26,57	31,54	35,10	42,59	47,39			25 x 9	37,20	
M 8x1,25	6,80 R	90 x 20 x 8,0 x 6,2	17,58	20,73	25,73	27,97	35,70	35,01	43,40	45,85	25 x 9	28,94	
M 10x1,00	9,00 D	90 x 16 x 7,0 x 5,5	24,97	31,32	36,84	42,30	49,73	58,75			38 x 10	45,46	
M 10x1,50	8,50 R	100 x 22 x 10,0 x 8,0	21,61	24,58	30,29	33,17	44,26	43,56	51,73	54,70	38 x 10	39,78	
		MANGO DELGADO		M2DP	M4DP	M2DT	M4DT	M2DHL	M4DHL	M2DSP	M4DSP		
M 12x1,50	10,50 D	100 x 22 x 9,0 x 7,0	29,63	35,82	39,19	44,13	55,65	63,84				38 x 10	47,27
M 12x1,75	10,20 D	110 x 24 x 9,0 x 7,0	27,86	33,09	36,68	41,36	48,50	58,20	65,08	69,99	38 x 14	41,73	
M 14x1,50	12,50 D	100 x 22 x 11,0 x 9,0	35,10	44,01	46,10	50,90	65,46	75,06			38 x 10	49,42	
M 14x2,00	12,00 D	110 x 26 x 11,0 x 9,0	34,84	40,38	45,27	49,76	66,15	72,71	66,45	88,69	38 x 14	42,54	
M 16x1,50	14,50 D	100 x 22 x 12,0 x 9,0	43,91	54,14	55,39	63,34	61,17	75,45			45 x 14	67,87	
M 16x2,00	14,00 D	110 x 27 x 12,0 x 9,0	40,96	48,81	51,68	57,13	75,52	83,47	90,70	95,65	45 x 18	57,14	
M 18x2,50	15,50 D	125 x 30 x 14,0 x 11,0	58,08	65,61	70,57	76,99	98,34	107,29	134,62	144,40	45 x 18	57,14	
M 20x2,50	17,50 D	140 x 32 x 16,0 x 12,0	62,74	69,93	80,43	86,66	112,09	120,79	143,47	150,35	45 x 18	57,14	
M 22x2,50	19,50 D	140 x 32 x 18,0 x 14,5	75,91	86,30	90,90	97,29	131,47	143,47			55 x 22	84,95	
M 24x3,00	21,00 D	160 x 34 x 18,0 x 14,5	90,25	103,31	102,42	111,29	148,14	164,10			55 x 22	84,95	

**MACHOS DE MÁQUINA PARA TRABAJOS ESPECIALES HSS-PM**

**INOX**

**M**

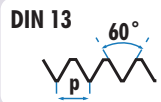

**TOL  
6H**

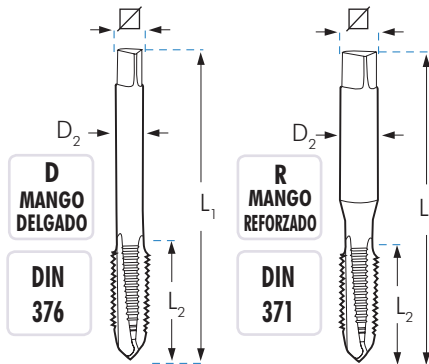

**Vc  
6 m/min**

**Vc  
10 m/min**

**Vc  
12 m/min**



			M2RX	M4RX	M2RXT	M4RXT	M2RXHL	M4RXHL
CALIDAD			★★	★★	★★★	★★★	★★★★	★★★★
MATERIAL			HSS PM	HSS PM	HSSCo 5%	HSSCo 5%	HSS PM	HSS PM
ACABADO			OX	OX	TiN	TiN	HARD LUBE	HARD LUBE
ÁNGULO DE HÉLICE			FORMA B	35°	FORMA B	35°	FORMA B	35°
		L1 x L2 x D2 x $\nabla$ mm	€	€	€	€	€	€
M 3x0,50	2,50	R 56 x 11 x 3,5 x 2,7	15,97	19,66	18,44	20,87	24,39	28,69
M 4x0,70	3,30	R 63 x 13 x 4,5 x 3,4	16,77	19,66	19,35	21,21	25,62	29,44
M 5x0,80	4,20	R 70 x 16 x 6,0 x 4,9	16,77	18,80	19,35	21,53	25,62	29,88
M 6x1,00	5,00	R 80 x 17 x 6,0 x 4,9	18,38	20,67	20,49	22,51	28,06	31,27
M 8x1,25	6,80	R 90 x 20 x 8,0 x 6,2	20,50	23,56	23,68	25,94	31,33	36,00
M 10x1,50	8,50	R 100 x 22 x 10,0 x 8,0	25,06	27,95	27,68	30,59	38,27	42,69
<b>MANGO DELGADO</b>			M2DX	M4DX	M2DXT	M4DXT	M2DXHL	M4DXHL
M 12x1,75	10,20	D 110 x 24 x 9,0 x 7,0	32,20	37,71	35,41	39,87	48,30	56,54
M 14x2,00	12,00	D 110 x 26 x 11,0 x 9,0	45,84	50,33	46,14	49,87	64,19	71,07
M 16x2,00	14,00	D 110 x 27 x 12,0 x 9,0	51,05	58,09	50,18	54,99	71,46	85,96
M 18x2,50	15,50	D 125 x 30 x 14,0 x 11,0	76,46	82,65	78,94	79,84	114,67	122,30
M 20x2,50	17,50	D 140 x 32 x 16,0 x 12,0	82,62	87,28	90,13	92,55	121,91	129,14
M 22x2,50	19,50	D 140 x 32 x 18,0 x 14,5			102,94	111,45		
M 24x3,00	21,00	D 160 x 34 x 18,0 x 14,5			114,06	123,91		



- Lubricación: **CUT MAGIC XTHICK**
- Se recomienda la aplicación del Aceite de corte CUT MAGIC XTHICK para optimizar el proceso de roscado en Inoxidables, Inconel, Titanio, Dúplex, etc...

Ref. ACXT00250



**MACHOS *Super Plus* PARA EL ROSCADO DE ALEACIONES REFRACTARIAS**

M

DIN 13

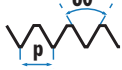
TOL  
6HINOX  
DUPLEX

Ni

INC

Ti

 ESPECIALMENTE RECOMENDADOS  
 EN APLICACIONES AERONAÚTICAS
Vc  
15  
m/minINOX  
DUPLEXVc  
6  
m/minNICKEL  
INCONELVc  
6  
m/min

TITANIO

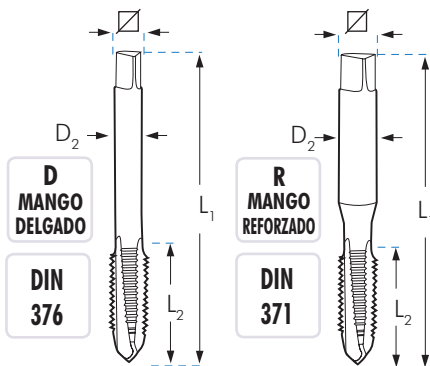

				M2RDU	M4RDU	M2RNI	M3RNI	M2RTIT	M3RTIT
CALIDAD				★★★★	★★★★	★★★★	★★★★	★★★★	★★★★
MATERIAL				HSS V3	HSS V3	HSS PM	HSS PM	HSS PM	HSS PM
ACABADO				TiCN	TiCN	BRILLANTE	BRILLANTE	OX	OX
ÁNGULO DE HÉLICE				FORMA B	41°	FORMA B	15°	FORMA B	15°
			L1 x L2 x D2 x ∅	€	€	€	€	€	€
M 3x0,50	2,50	R 56 x 11 x 3,5 x 2,7		33,71	35,15	62,63	63,99	46,50	51,32
M 4x0,70	3,30	R 63 x 13 x 4,5 x 3,4		33,71	34,43	63,99	65,72	47,94	51,32
M 5x0,80	4,20	R 70 x 16 x 6,0 x 4,9		34,83	35,52	66,25	67,81	49,15	54,66
M 6x1,00	5,00	R 80 x 17 x 6,0 x 4,9		35,80	36,56	66,77	68,66	49,15	55,43
M 8x1,25	6,80	R 90 x 20 x 8,0 x 6,2		50,00	52,13	75,46	77,47	56,79	63,99
M 10x1,50	8,50	R 100 x 22 x 10,0 x 8,0		64,80	66,49	89,66	92,39	70,35	77,11
		<b>MANGO DELGADO</b>		M2DDU	M4DDU	M2DNI	M3DNI	M2DTIT	M3DTIT
M 12x1,75	10,20	D 110 x 24 x 9,0 x 7,0		87,60	94,60	115,32	127,50	88,29	95,81
M 14x2,00	12,00	D 110 x 26 x 11,0 x 9,0							
M 16x2,00	14,00	D 110 x 27 x 12,0 x 9,0		128,83	137,76				
M 18x2,50	15,50	D 125 x 30 x 14,0 x 11,0							
M 20x2,50	17,50	D 140 x 32 x 16,0 x 12,0		190,77	206,06				
M 22x2,50	19,50	D 140 x 32 x 18,0 x 14,5							
M 24x3,00	21,00	D 160 x 34 x 18,0 x 14,5		258,39	262,81				
M 27x3,00	24,00	D 160 x 36 x 20,0 x 16,0		331,95	347,96				
M 30x3,50	26,50	D 180 x 40 x 22,0 x 18,0		392,05	410,23				

**MACHOS DE MÁQUINA PARA ACEROS ESTRUCTURALES SUPER BLANDOS < DE 450 N/mm<sup>2</sup>**

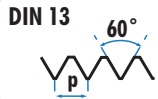

**HSSCo**  
5%

**OX**

**TOL**  
6H

**APLICACIONES**

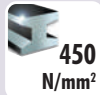



**ST52**

**AI**

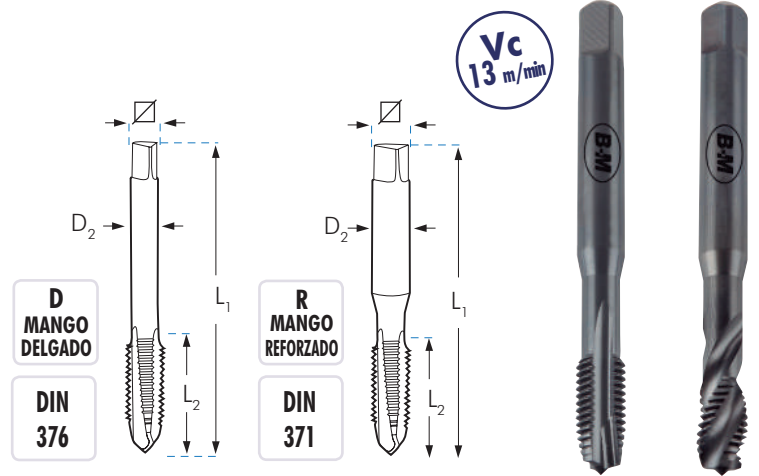
Geometría de corte específica para materiales blandos, no genera SOBREMEDIDA y se ajusta perfectamente a este tipo de materiales donde los machos convencionales, pueden provocar agrandamientos a la hora de generar la rosca.



		L <sub>1</sub> x L <sub>2</sub> x D <sub>2</sub> x $\nabla$ mm	M2RSS	M4RSS
			FORMA B	35°
			€	€
M 3 x 0,50	2,50	R 56 x 11 x 3,5 x 2,7	12,46	16,33
M 4 x 0,70	3,30	R 63 x 13 x 4,5 x 3,4	13,03	16,34
M 5 x 0,80	4,20	R 70 x 16 x 6,0 x 4,9	13,06	15,67
M 6 x 1,00	5,00	R 80 x 17 x 6,0 x 4,9	14,32	17,18
M 8 x 1,25	6,80	R 90 x 20 x 8,0 x 6,2	16,07	19,44
M 10 x 1,50	8,50	R 100 x 22 x 10,0 x 8,0	19,79	23,02
<b>MANGO DELGADO</b>			M2DSS	M4DSS
M 12 x 1,75	10,20	D 110 x 24 x 9,0 x 7,0	24,95	29,65
M 14 x 2,00	12,00	D 110 x 26 x 11,0 x 9,0	36,84	42,69
M 16 x 2,00	14,00	D 110 x 27 x 12,0 x 9,0	43,09	51,57
M 18 x 2,50	15,50	D 125 x 30 x 14,0 x 11,0	61,39	66,87
M 20 x 2,50	17,50	D 140 x 32 x 16,0 x 12,0	66,27	74,12
M 22 x 2,50	19,50	D 140 x 32 x 18,0 x 14,5	79,54	86,99
M 24 x 3,00	21,00	D 160 x 34 x 18,0 x 14,5	94,75	105,74
M 27 x 3,00	24,00	D 160 x 36 x 20,0 x 16,0	118,51	130,10
M 30 x 3,50	26,50	D 180 x 40 x 22,0 x 18,0	152,26	166,73

**MACHOS DE MÁQUINA PARA TRABAJOS ESPECIALES HSS-V3**

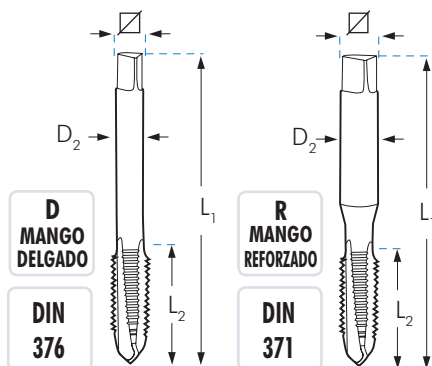
**HSS  
V3**
**TOL  
6H**
**MATERIALES  
DUROS**

**Vc  
7 m/min**
**Vc  
9 m/min**

		M2RMD	M4RMD	M2RMDTX	M4RMDTX
CALIDAD		★★★	★★★	★★★★	★★★★
MATERIAL		HSS V3	HSS V3	HSS V3	HSS V3
ACABADO		OX	OX	TINALOX	TINALOX
ÁNGULO DE HÉLICE		FORMA B	35°	FORMA B	35°
	$L_1 \times L_2 \times D_2 \times \square$ mm	€	€	€	€
M 3x0,50	2,50 R 56 x 11 x 3,5 x 2,7	14,53	15,90	21,30	25,05
M 4x0,70	3,30 R 63 x 13 x 4,5 x 3,4	14,31	15,81	22,38	26,23
M 5x0,80	4,20 R 70 x 16 x 6,0 x 4,9	14,31	16,58	22,38	26,23
M 6x1,00	5,00 R 80 x 17 x 6,0 x 4,9	16,54	17,29	24,51	27,57
M 8x1,25	6,80 R 90 x 20 x 8,0 x 6,2	17,67	20,40	27,36	31,45
M 10x1,50	8,50 R 100 x 22 x 10,0 x 8,0	20,36	23,50	34,63	38,62
<b>MANGO DELGADO</b>		M2DMD	M4DMD	M2DMDTX	M4DMDTX
M 12x1,75	10,20 D 110 x 24 x 9,0 x 7,0	28,01	32,31	44,50	52,10
M 14x2,00	12,00 D 110 x 26 x 11,0 x 9,0	36,75	38,36	63,33	69,53
M 16x2,00	14,00 D 110 x 27 x 12,0 x 9,0	41,10	46,40	70,55	84,09
M 18x2,50	15,50 D 125 x 30 x 14,0 x 11,0	61,28	66,02	103,70	117,45
M 20x2,50	17,50 D 140 x 32 x 16,0 x 12,0	66,23	69,70	112,08	123,98

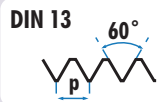
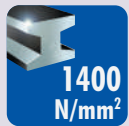
**MACHOS DE MÁQUINA PARA MATERIALES TEMPLADOS (HARDOX 450/500)**



TiCN

TOL  
6H

HSS  
PM

MATERIALES  
MUY  
DUROS

48  
HRC

48-62  
HRC

Vc  
5 m/min

MD

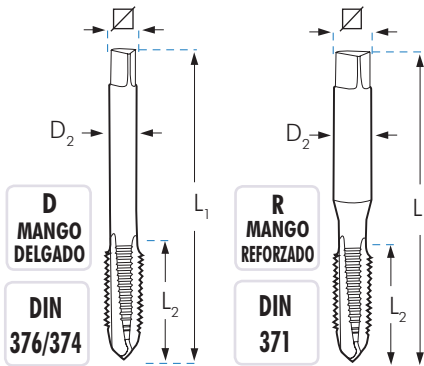

Icon	Forma	L1 x L2 x D2 x $\square$ mm	M2RC M3RC M2HRC M4HRC				M1RHMC	
			FORMA B	15°	FORMA B	35°	FORMA C	€
€	€	€	€	€	€	€	€	
M 2 x 0,40	1,60	R 40 x 9 x 2,5 x 2,1			33,25	36,36	1,70	
M 3 x 0,50	2,50	R 56 x 11 x 3,5 x 2,7	30,34	32,28	30,34	33,98	2,60	99,51
M 4 x 0,70	3,30	R 63 x 13 x 4,5 x 3,4	31,51	34,38	31,51	35,29	3,40	99,51
M 5 x 0,80	4,20	R 70 x 16 x 6,0 x 4,9	31,81	33,59	31,81	35,63	4,30	99,51
M 6 x 1,00	5,00	R 80 x 17 x 6,0 x 4,9	33,18	39,03	33,18	37,16	5,10	124,39
M 8 x 1,25	6,80	R 90 x 20 x 8,0 x 6,2	38,33	43,73	41,25	46,20	6,90	140,00
M 10 x 1,50	8,50	R 100 x 22 x 10,0 x 8,0	45,88	54,18	49,37	51,83	8,60	214,81
MANGO DELGADO			M2DC	M3DC	M2HDC	M4HDC	M1DHMC	
M 12 x 1,75	10,20	D 110 x 24 x 9,0 x 7,0	68,61	106,49	75,36	82,14	10,40	336,42
M 14 x 2,00	12,00	D 110 x 26 x 11,0 x 9,0	92,63	108,34	89,36	97,40	12,10	387,66
M 16 x 2,00	14,00	D 110 x 27 x 12,0 x 9,0	104,52	124,45	99,36	108,30	16,10	506,20
M 18 x 2,50	15,50	D 125 x 30 x 14,0 x 11,0	132,35	188,45	105,10	114,56	15,75	618,42
M 20 x 2,50	17,50	D 140 x 32 x 16,0 x 12,0	209,60	218,15	145,25	158,32	17,75	978,24
M 22 x 2,50	19,50	D 140 x 32 x 18,0 x 14,5			179,36	196,36		
M 24 x 3,00	21,00	D 160 x 34 x 18,0 x 14,5			196,36	214,03		
M 27 x 3,00	24,00	D 160 x 36 x 20,0 x 16,0			245,25	276,36		
M 30 x 3,50	26,50	D 180 x 40 x 22,0 x 18,0			301,25	325,36		

HRc	Vc (m/min)
48 Hrc	8 m/min
56 Hrc	6 m/min
62Hrc	3 m/min

- Lubricación: **CUT MAGIC XTHICK**
- Se recomienda roscar la pieza sobre el mismo utillaje utilizado para el taladro previo y en la misma posición, para garantizar coaxialidad entre macho y orificio previo.



Ref. ACXT00250

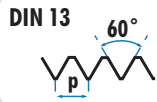
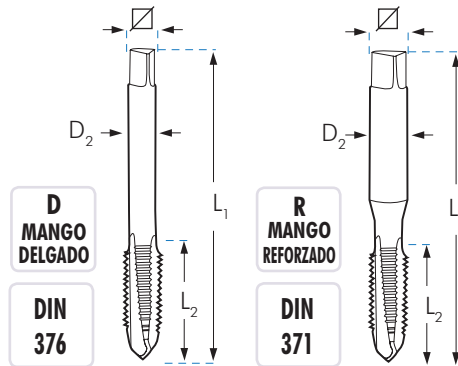

**MACHOS DE MÁQUINA TODO TERRENO**
**TODO  
TERRENO**

**HSSCo  
5%**
**TiN**
**TOL  
6H**
**APLICACIONES**
**1200  
N/mm<sup>2</sup>**
**Al**
**FUNDICIÓN**
**Ti**
**INOX**
**Vc  
13  
m/min**

				M2RD	M4RD
		L <sub>1</sub> x L <sub>2</sub> x D <sub>2</sub> x		FORMA B	
		mm		€	€
M 3 x 0,50	2,50	R	56 x 11 x 3,5 x 2,7	22,84	28,55
M 4 x 0,70	3,30	R	63 x 13 x 4,5 x 3,4	24,44	28,55
M 5 x 0,80	4,20	R	70 x 16 x 6,0 x 4,9	26,00	29,57
M 6 x 1,00	5,00	R	80 x 17 x 6,0 x 4,9	26,91	30,70
M 8 x 1,25	6,80	R	90 x 20 x 8,0 x 6,2	31,52	35,03
M 10 x 1,50	8,50	R	100 x 22 x 10,0 x 8,0	36,37	41,49
<b>MANGO DELGADO</b>				M2DD	M4DD
M 12 x 1,75	10,20	D	110 x 24 x 9,0 x 7,0	45,83	54,56
M 14 x 2,00	12,00	D	110 x 26 x 11,0 x 9,0	59,86	65,77
M 16 x 2,00	14,00	D	110 x 27 x 12,0 x 9,0	67,07	72,59
M 18 x 2,50	15,50	D	125 x 30 x 14,0 x 11,0	104,81	107,47
M 20 x 2,50	17,50	D	140 x 32 x 16,0 x 12,0	106,75	110,76

MACHOS DE MÁQUINA PARA TRABAJOS ESPECIALES HSSCo

**Al**

**FUNDICIÓN**

**LATÓN**

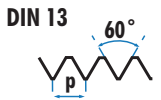

**HSSCo**  
5%

**TOL**  
6H

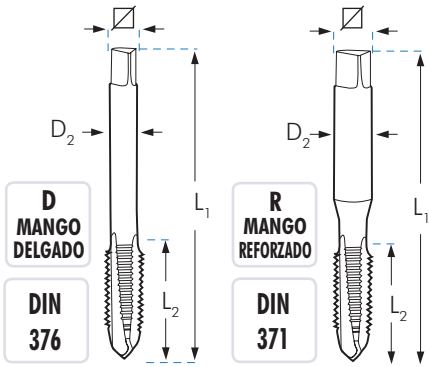

**Vc**  
18 m/min

**Vc**  
11 m/min

**Vc**  
21 m/min

**Vc**  
16 m/min

**Vc**  
19 m/min



APLICACIÓN		M5R	M6R	M1RFM	MHMTR	M1RL	M1RLCRN	
MATERIAL		Al	Al	FUNDICIÓN	FUNDICIÓN	LATÓN	LATÓN	
ACABADO		HSSCo 5%	HSSCo 5%	HSSCo 5%	MD	HSSCo 5%	HSSCo 5%	
FORMA		BRILLANTE	BRILLANTE	OX	BRILLANTE	BRILLANTE	CrN	
FORMA		DIENTE ALTERNO	2 CANALES	FORMA C	FORMA C	FORMA C	FORMA C	
		€	€	€	€	€	€	
M 3x0,50	2,50	R 56 x 11 x 3,5 x 2,7	19,71	21,15	13,94	70,68	16,70	18,96
M 4x0,70	3,30	R 63 x 13 x 4,5 x 3,4	19,81	21,15	14,42	70,68	17,72	20,90
M 5x0,80	4,20	R 70 x 16 x 6,0 x 4,9	19,71	21,59	14,42	70,68	17,72	20,98
M 6x1,00	5,00	R 80 x 17 x 6,0 x 4,9	20,77	23,35	16,37	80,62	19,43	22,91
M 8x1,25	6,80	R 90 x 20 x 8,0 x 6,2	24,86	27,98	18,33	90,01	22,14	27,86
M 10x1,50	8,50	R 100 x 22 x 10,0 x 8,0	29,98	33,09	20,97	112,80	26,64	33,89
MANGO DELGADO		M5D	M6D	M1DFM	MHM1D	M1DL	M1DLCRN	
M 12x1,75	10,20	D 110 x 24 x 9,0 x 7,0	37,40	40,82	26,38	154,46	31,08	40,96
M 14x2,00	12,00	D 110 x 26 x 11,0 x 9,0	67,73	70,49	43,35	240,63	38,16	49,92
M 16x2,00	14,00	D 110 x 27 x 12,0 x 9,0	73,82	79,94	51,01	286,27	43,90	55,81
M 18x2,50	15,50	D 125 x 30 x 14,0 x 11,0			71,36	350,91	57,58	70,69
M 20x2,50	17,50	D 140 x 32 x 16,0 x 12,0			71,63	424,94	64,63	78,70



- Lubricación: **CUT MAGIC ALUMINIO**
- Se recomienda la aplicación del Aceite de corte CUT MAGIC ALUMINIO para optimizar el proceso de roscado en Aluminio y sus fundiciones.

Ref. ACAL00250

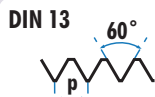
**MACHOS DE MÁQUINA PARA ROSCADO POR LAMINACIÓN**

**HSSCo**  
**5%**
**HSSCo**  
**8%**
**TOL**  
**6HX**
**APLICACIONES**

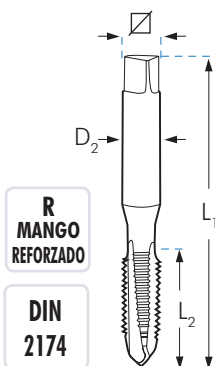
**Al**
**FUNDICIÓN**

*Plus*
**INOX**

APLICACIÓN		M07R	M07RT	M07RCR	M07RCCR	M09RCCR	M07RXTCR	
MATERIAL		HSSCo 5%	HSSCo 5%	HSSCo 5%	HSSCo 5%	HSSCo 8%	HSSCo 5%	
ACABADO		OX	TiN	OX	TiCN	TiCN	TiN	
FORMA								
		L1 x L2 x D2 x $\nabla$ mm	€	€	€	€	€	
M 3x0,50	2,75	R 56 x 11 x 3,5 x 2,7	27,14	29,45	29,04	33,10	89,29	66,59
M 3,5x0,60	3,20	R 56 x 11 x 3,5 x 2,7	28,52	32,49	30,00	35,03		
M 4x0,70	3,65	R 63 x 13 x 4,5 x 3,4	27,14	30,72	29,04	34,52	90,42	66,59
M 5x0,80	4,60	R 70 x 16 x 6,0 x 4,9	27,14	30,72	29,04	34,52	91,63	71,87
M 6x1,00	5,50	R 80 x 17 x 6,0 x 4,9	29,30	32,47	31,33	36,48	93,07	71,87
M 8x1,25	7,40	R 90 x 20 x 8,0 x 6,2	34,14	42,85	36,53	48,16	103,25	86,01
M 10x1,50	9,30	R 100 x 22 x 10,0 x 8,0	37,97	48,05	40,63	53,01	123,28	105,00
<b>MANGO DELGADO</b>		M07D	M07DT	M07DCR	M07DCCR	M09DCCR	M07DXTCR	
M 12x1,75	11,20	D 110 x 24 x 9,0 x 7,0	44,75	62,83	46,10	60,70	145,93	136,73
M 14x2,00	13,05	D 110 x 26 x 11,0 x 9,0	80,68	99,23	81,50	98,54	181,60	196,70
M 16x2,00	15,05	D 110 x 27 x 12,0 x 9,0	94,72	111,76	95,67	100,14	249,78	200,11
M 18x2,50	16,80	D 125 x 30 x 14,0 x 11,0	108,69	133,63	109,78	123,26	295,96	
M 20x2,50	18,80	D 140 x 32 x 16,0 x 12,0	143,21	202,29	144,66	172,97	327,65	

**MACHOS DE MÁQUINA HSSCo TOLERANCIAS ESPECIALES Y SOBREMEDIDAS**



		M2R4H	M4R4H	M2R6G	M4R6G	M2R7G	M4R7G	M2R+0,1	M4R+0,1	M2R+0,2	M4R+0,2
TOLERANCIA		TOL 4H	TOL 4H	TOL 6G	TOL 6G	TOL 7G	TOL 7G	TOL 6H (+0,1)	TOL 6H (+0,1)	TOL 6H (+0,2)	TOL 6H (+0,2)
MATERIAL		HSSCo 5%	HSSCo 5%	HSSCo 5%	HSSCo 5%	HSSCo 5%	HSSCo 5%	HSSCo 5%	HSSCo 5%	HSSCo 5%	HSSCo 5%
ACABADO		BRILLANTE	BRILLANTE	BRILLANTE	BRILLANTE	BRILLANTE	BRILLANTE	BRILLANTE	BRILLANTE	BRILLANTE	BRILLANTE
FORMA		FORMA B	FORMA B 35°	FORMA B	FORMA B 35°	FORMA B	FORMA B 35°	FORMA B	FORMA B 35°	FORMA B	FORMA B 35°
		€	€	€	€	€	€	€	€	€	€
M 3x0,50	2,50 R 56x11x 3,5x 2,7	19,61	24,26	14,39	17,12	19,61	24,26	20,24	27,01	23,23	28,76
M 4x0,70	3,30 R 63x13x 4,5x 3,4	20,07	24,26	14,39	17,12	20,07	24,26	20,73	27,01	23,76	28,76
M 5x0,80	4,20 R 70x16x 6,0x 4,9	20,07	23,24	14,39	16,80	20,07	23,24	20,73	25,87	23,76	27,54
M 6x1,00	5,00 R 80x17x 6,0x 4,9	22,06	25,50	15,49	18,45	22,06	25,50	22,75	28,39	26,12	30,23
M 8x1,00	7,00 D 90x20x 6,0x 4,9			30,17	33,37						
M 8x1,25	6,75 R 90x20x 8,0x 6,2	24,70	29,12	18,01	21,62	24,70	29,12	25,50	32,40	29,26	34,51
M 10x1,00	9,00 D 90x16x 7,0x 5,5			35,63	41,47						
M 10x1,50	8,50 R 100x22x10,0x 8,0	30,37	34,56	22,16	24,74	30,37	34,56	31,36	38,42	36,01	40,91
	<b>MANGO DELGADO</b>	M2D4H	M4D4H	M2D6G	M4D6G	M2D7G	M4D7G	M2D+0,1	M4D+0,1	M2D+0,2	M4D+0,2
M 12x1,50	10,50 D 100x22x 9,0x 7,0			64,92	76,97						
M 12x1,75	10,20 D 110x24x 9,0x 7,0	39,17	46,49	29,23	35,21	39,17	46,49	39,28	49,80	44,64	53,04
M 14x2,00	12,00 D 110x26x11,0x 9,0			35,91	43,14			64,08	79,29	72,83	84,43
M 16x2,00	14,00 D 110x27x12,0x 9,0			44,38	52,10			75,38	95,81	85,68	102,03
M 18x2,50	15,50 D 125x30x14,0x11,0			62,58	64,51			113,97	129,03	121,36	137,40
M 20x2,50	17,50 D 140x32x16,0x12,0			64,63	74,14			123,15	137,31	131,13	146,21

4H.- Para roscas muy precisas. Ajuste más exacto.

6G.- Para roscas con recubrimientos. Espesores entre 20 - 40 μ

7G.- Para roscas con recubrimientos. Espesores entre 40 - 50 μ

6H. (+0,1)- Hay que añadir 0,10mm a la broca previa.

6H. (+0,2)- Hay que añadir 0,20mm a la broca previa.



## MACHOS DE MÁQUINA EXTRALARGOS HSSCo

FORMA  
BHSSCo  
5%

BRILLANTE

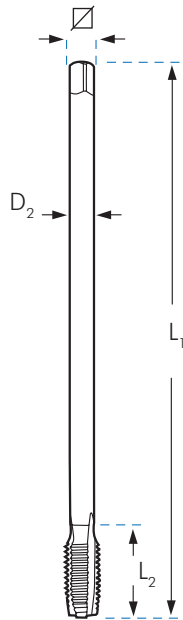
TOL  
6HR  
MANGO  
REFORZADODIN  
371D  
MANGO  
DELGADODIN  
376

				M2L	
				FORMA B	€
			$L_1 \times L_2 \times D_2 \times \square$ mm		
M	3x0,50	2,50	R 100 x 10 x 3,5 x 2,7		31,89
M	4x0,70	3,30	R 120 x 12 x 4,5 x 3,4		32,59
M	5x0,80	4,20	R 140 x 14 x 6,0 x 4,9		32,59
M	6x1,00	5,00	R 160 x 16 x 6,0 x 4,9		35,82
M	7x1,00	6,00	R 160 x 17 x 7,0 x 5,5		39,90
M	8x1,25	6,80	R 180 x 18 x 8,0 x 6,2		41,99

		MANGO DELGADO		M2L-D	
					€
M	6x1,00	5,00	D 160 x 16 x 4,5 x 3,4		36,48
M	8x1,25	6,80	D 180 x 18 x 6,2 x 5,0		42,79
M	10x1,50	8,50	D 200 x 20 x 7,0 x 5,5		51,69
M	12x1,75	10,20	D 220 x 22 x 8,5 x 6,5		63,60
M	14x2,00	12,00	D 220 x 25 x 10,5 x 8,0		96,82
M	16x2,00	14,00	D 220 x 28 x 12,5 x 10,0		113,89
M	18x2,50	15,50	D 250 x 32 x 14,0 x 11,0		207,23
M	20x2,50	17,50	D 250 x 32 x 16,0 x 12,0		223,99

HSSCo  
5%

BRILLANTE

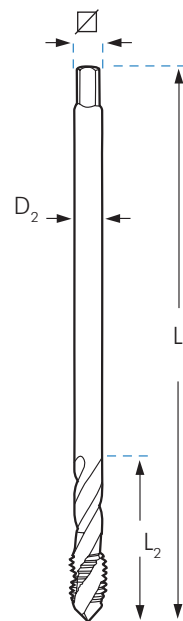
TOL  
6HR  
MANGO  
REFORZADODIN  
371D  
MANGO  
DELGADODIN  
376

				M4L	
				FORMA B 35°	€
			$L_1 \times L_2 \times D_2 \times \square$ mm		
M	3x0,50	2,50	R 100 x 10 x 3,5 x 2,7		39,46
M	4x0,70	3,30	R 120 x 12 x 4,5 x 3,4		39,46
M	5x0,80	4,20	R 140 x 14 x 6,0 x 4,9		37,80
M	6x1,00	5,00	R 160 x 16 x 6,0 x 4,9		41,48
M	7x1,00	6,00	R 160 x 17 x 7,0 x 5,5		46,18
M	8x1,25	6,80	R 180 x 18 x 8,0 x 6,2		50,39

		MANGO DELGADO		M4L-D	
					€
M	6x1,00	5,00	D 160 x 16 x 4,5 x 3,4		42,26
M	8x1,25	6,80	D 180 x 18 x 6,2 x 5,0		49,44
M	10x1,50	8,50	D 200 x 20 x 7,0 x 5,5		58,40
M	12x1,75	10,20	D 220 x 22 x 8,5 x 6,5		75,55
M	14x2,00	12,00	D 220 x 25 x 10,5 x 8,0		108,49
M	16x2,00	14,00	D 220 x 28 x 12,5 x 10,0		157,23
M	18x2,50	15,50	D 250 x 32 x 14,0 x 11,0		234,65
M	20x2,50	17,50	D 250 x 32 x 16,0 x 12,0		249,73

**MACHO TUERQUERO DE ROSCA MÉTRICA DIN 357**



**HSSCo**  
5%

**BRILLANTE**

**TOL**  
6H

**DIN**  
357

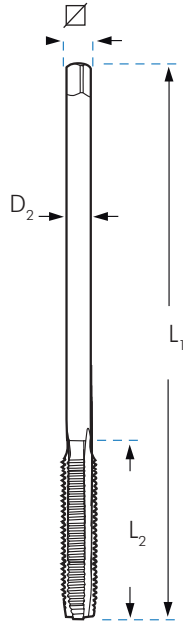

				MTU	
				FORMA	
				A	€
		L <sub>1</sub> x L <sub>2</sub> x D <sub>2</sub> x			
		mm			
M	3x0,50*	2,50	D 70 x 22 x 2,2		21,47
M	4x0,70	3,30	D 90 x 25 x 2,8 x 2,1		21,47
M	5x0,80	4,20	D 100 x 28 x 3,5 x 2,7		21,47
M	6x1,00	5,00	D 110 x 32 x 4,5 x 3,4		21,47
M	8x1,25	6,80	D 125 x 40 x 6,0 x 4,9		25,89
M	10x1,50	8,50	D 140 x 45 x 7,0 x 5,5		25,30
M	12x1,75	10,20	D 180 x 50 x 9,0 x 7,0		30,65
M	14x2,00	12,00	D 200 x 56 x 11,0 x 9,0		48,42
M	16x2,00	14,00	D 200 x 63 x 12,0 x 9,0		59,95
M	18x2,50	15,50	D 220 x 63 x 14,0 x 11,0		80,66
M	20x2,50	17,50	D 250 x 70 x 16,0 x 12,0		113,86
M	22x2,50	19,50	D 280 x 80 x 18,0 x 14,5		139,70
M	24x3,00	21,00	D 280 x 80 x 18,0 x 14,5		190,07

\* Mango cilíndrico

Machos y Terrajas

Rosa

**BLUE-MASTER**  
by CELESA

CONSULTE NUESTRA AMPLIA GAMA DE HERRAMIENTAS PARA LA REPARACIÓN DE ROSCAS



**INSERTOS LIBRES**

**INSERTOS SÓLIDOS CON SELLADOR ANAERÓBICO**

**INSERTOS AUTORROSCANTES**

**CASQUILLOS ROSCADOS DE SEGURIDAD**

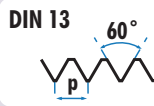
**BROCA MACHO HSSCo**

**HSSCo**  
 5%

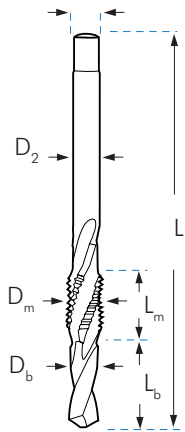
BRILLANTE

**TOL**  
**6H**
**R**  
**MANGO**  
**REFORZADO**
**DIN**  
**371**
**D**  
**MANGO**  
**DELGADO**
**DIN**  
**376**

		L <sub>b</sub> mm	L <sub>m</sub> mm	L <sub>1</sub> mm	D <sub>b</sub> mm	D <sub>m</sub> mm	D <sub>2</sub> mm	∅ mm	M8M €
M 3x0,50	R	9,0	12,5	62,0	2,50	3,0	3,5	2,7	32,31
M 4x0,70	R	10,0	16,0	66,0	3,30	4,0	4,5	3,4	32,31
M 5x0,80	R	12,5	18,0	75,5	4,20	5,0	6,0	4,9	33,58
M 6x1,00	R	14,0	20,0	81,0	5,00	6,0	6,0	4,9	37,09
M 8x1,00	R	20,0	14,0	91,0	7,00	8,0	6,0	4,9	43,52
M 8x1,25	R	20,0	14,0	91,0	6,75	8,0	8,0	6,2	45,15

**MANGO DELGADO**

M 8x1,25	D	20,0	14,0	91,0	6,75	8,0	6,0	4,9	45,15
M 10x1,00	D	20,0	15,0	95,0	9,00	10,0	7,0	5,5	54,03
M 10x1,50	D	25,0	18,0	105,0	8,50	10,0	7,0	5,5	57,34
M 12x1,50	D	24,0	18,0	110,0	10,50	12,0	9,0	7,0	62,59
M 12x1,75	D	28,0	20,0	118,0	10,20	12,0	9,0	7,0	62,22
M 14x1,50	D	28,0	20,0	118,0	12,50	14,0	11,0	9,0	99,04
M 14x2,00	D	28,0	22,0	130,0	12,00	14,0	11,0	9,0	112,65
M 18x2,50	D	40,0	26,0	151,0	15,50	18,0	14,0	11,0	216,09
M 20x2,50	D	45,0	30,0	168,0	17,50	20,0	16,0	12,0	310,32

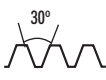
 Nota: Jamás emplee los Broca-Machos en agujeros ciegos o en pasantes más profundos que L<sub>b</sub>
**MACHO DE MÁQUINA ROSCA TRAPEZOIDAL HSS**

**HSS**

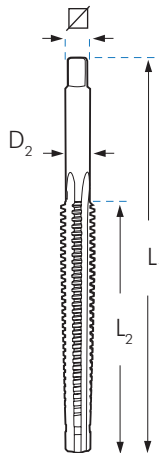
BRILLANTE

**DIN**  
**103**
**TOL**  
**7H**

			L <sub>1</sub> x L <sub>2</sub> x D <sub>2</sub> x ∅ mm	MRTM €
Tr 14 x 3	11,25	160 x 105 x 10,5 x 8,0	507,68	
Tr 16 x 4	12,25	205 x 110 x 11,5 x 9,0	528,52	
Tr 18 x 4	14,25	215 x 120 x 13,0 x 10,0	557,14	
Tr 20 x 4	16,25	230 x 130 x 15,0 x 12,0	559,75	
Tr 22 x 5	17,25	270 x 165 x 16,0 x 12,0	736,79	
Tr 24 x 5	19,25	280 x 165 x 18,0 x 14,5	835,73	
Tr 26 x 5	21,25	290 x 170 x 20,0 x 16,0	864,72	
Tr 28 x 5	23,25	300 x 180 x 22,0 x 18,0	979,54	
Tr 30 x 6	24,25	345 x 200 x 23,0 x 18,0	1.127,31	

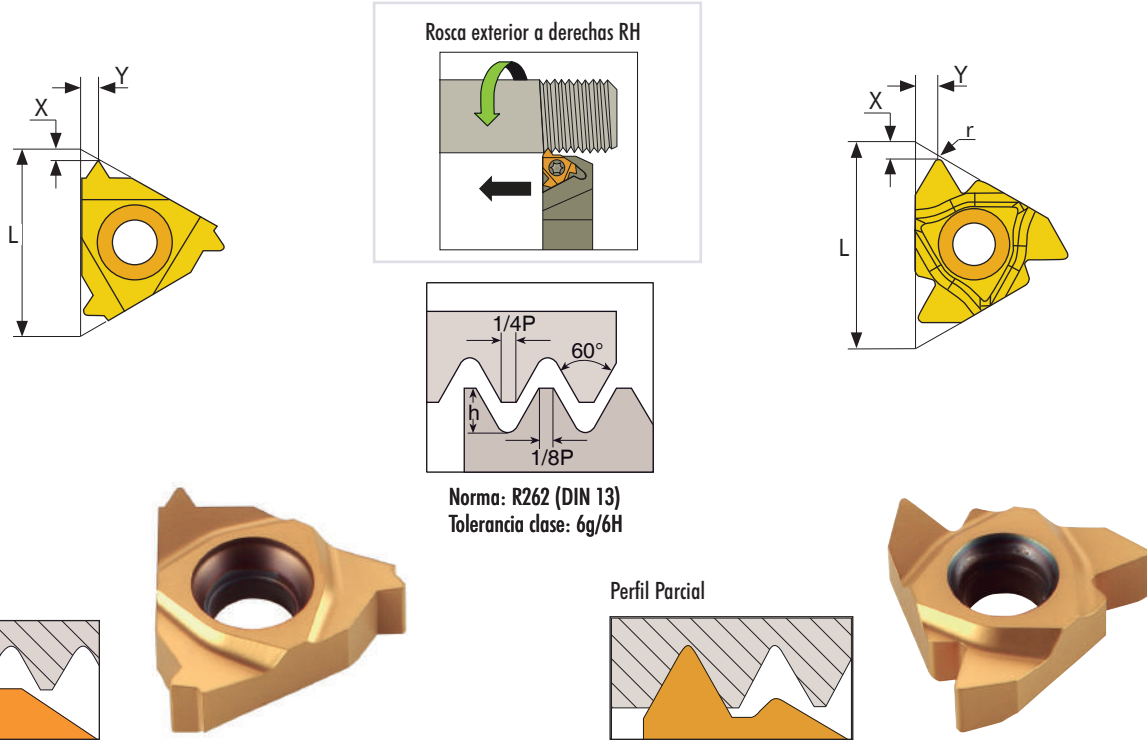
PLAQUITAS PARA ROSCADO DE EXTERIORES



Rosca exterior a derechas RH

Norma: R262 (DIN 13)  
Tolerancia clase: 6g/6H

Perfil Total

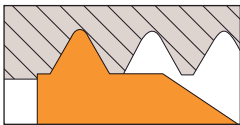

Perfil Parcial

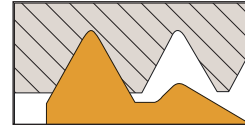

Rosca el perfil completo, terminando el diámetro exterior de la rosca.  
Utilizaremos una plaquita diferente para cada paso.

No termina el diámetro exterior de la rosca.  
La misma plaquita puede ser utilizada para una gama de diferentes pasos, que tengan el mismo ángulo de rosca.

PERFIL TOTAL 60°

ROSCADO EXTERIOR	L	PASO	h	X	Y	€
PRE-16-075	16	0,75	0,46	0,6	0,6	22,74
PRE-16-100		1,00	0,61	0,7	0,7	22,74
PRE-16-125		1,25	0,77	0,8	0,9	22,74
PRE-16-150		1,50	0,92	0,8	1	22,74
PRE-16-175		1,75	1,07	0,9	1,2	22,74
PRE-16-200		2,00	1,23	1	1,3	22,74
PRE-16-250		2,50	1,53	1,1	1,5	22,74
PRE-16-300		3,00	1,84	1,2	1,6	22,74

PERFIL PARCIAL 60°

ROSCADO EXTERIOR	L	RANGOS MÉTRICOS	RANGO PULGADAS	r	X	Y	€
PPRE-16-150	16	0,50-1,50	48 - 16	0,05	0,80	0,90	22,74
PPRE-16-300		1,75-3,00	14 - 8	0,27	1,20	1,70	22,74

PORTAHERRAMIENTAS DE ROSCADO DE EXTERIORES

ROSCADO EXTERIOR	H1=H=B=F	L1	L2	€
PEXT-20-16	20	128	30	145,68
PEXT-25-16	25	153	30	166,31

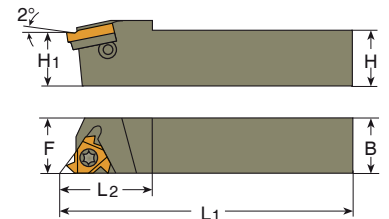

	Vc		Vc
ACERO BLANDO 70 kg/mm <sup>2</sup> BC2	25 m/min	ALUMINIO BC16	50 m/min
ACERO TRATADO 120 kg/mm <sup>2</sup> BC5	13 m/min	TITANIO BC42	18 m/min
INOXIDABLE BC50	11 m/min	FUNDICIÓN BC7	25 m/min
		LATÓN BC66	50 m/min

FÓRMULA MATEMÁTICA PARA OBTENER LA VELOCIDAD DE GIRO DE LA PIEZA (RPM)

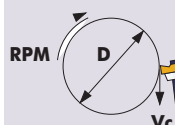

$$RPM = \frac{1000 \times Vc}{\pi \times D}$$

RPM: Revoluciones x minuto  
Vc: Velocidad de Corte (m/min)  
D: Diámetro Pieza (mm)

Las RPM-s se Obtienen en función de Vc y D



## PLAQUITAS PARA ROSCADO DE INTERIORES

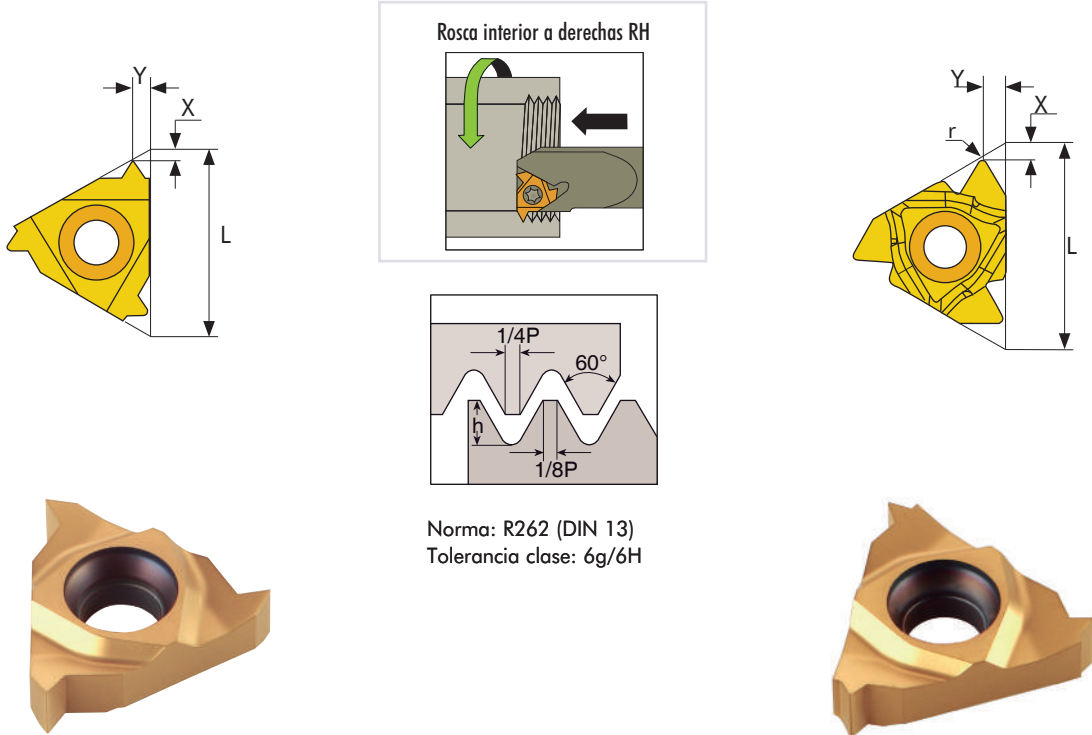

## PERFIL TOTAL 60°

ROSCADO INTERIOR	L	PASO	h	X	Y	€
PRI-16-075	16	0,75	0,43	0,6	0,6	22,74
PRI-16-100		1,00	0,58	0,6	0,7	22,74
PRI-16-125		1,25	0,72	0,8	0,9	22,74
PRI-16-150		1,50	0,87	0,8	1,0	22,74
PRI-16-175		1,75	1,01	0,9	1,2	22,74
PRI-16-200		2,00	1,15	1,0	1,3	22,74
PRI-16-250		2,50	1,44	1,1	1,5	22,74
PRI-16-300		3,00	1,73	1,1	1,5	22,74

## PERFIL PARCIAL 60°

ROSCADO INTERIOR	L	RANGOS MÉTRICOS	RANGO PULGADAS	r	X	Y	€
PPRI-16-150	16	0,50-1,50	48 - 16	0,05	0,80	0,90	22,74
PPRI-16-300		1,75-3,00	14 - 8	0,16	1,20	1,70	22,74

## PORTAHERRAMIENTAS DE ROSCADO DE INTERIORES

ROSCADO INTERIOR	L	L1	D	D1	A	Ø Mín. agujero	€
PINT-20-16	180	40	20	20	18	24	163,92
PINT-25-16	200	45	25	24,6	22,6	29	200,42

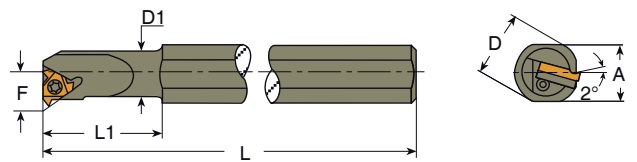

**MACHOS DE MÁQUINA HSSCo EN ESTUCHES METÁLICOS**

**USO  
GENERAL**

**HSSCo  
5%**



Ref. JM6



Ref. JM2





Ref. JM8



Ref. JM4

**CONTENIDO**

	FORMA C	FORMA B	 15°	 35°	 HSS	HSS Co 5% €
JM5	M3 - M4 - M5 - M6 M8 - M10 - M12	-	-	-	-	92,17
JM1	M3 - M4 - M5 - M6 M8 - M10 - M12	-	-	-	2.5 / 3.3 / 4.2 / 5.0 6.8 / 8.5 / 10.2 mm	110,24
JM6	-	M3 - M4 - M5 - M6 M8 - M10 - M12	-	-	-	98,20
JM2	-	M3 - M4 - M5 - M6 M8 - M10 - M12	-	-	2.5 / 3.3 / 4.2 / 5.0 6.8 / 8.5 / 10.2 mm	110,44
JM7	-	-	M3 - M4 - M5 - M6 M8 - M10 - M12	-	-	122,34
JM3	-	-	M3 - M4 - M5 - M6 M8 - M10 - M12	-	2.5 / 3.3 / 4.2 / 5.0 6.8 / 8.5 / 10.2 mm	146,18
JM8	-	-	-	M3 - M4 - M5 - M6 M8 - M10 - M12	-	124,45
JM4	-	-	-	M3 - M4 - M5 - M6 M8 - M10 - M12	2.5 / 3.3 / 4.2 / 5.0 6.8 / 8.5 / 10.2 mm	144,62



## MACHOS DE MÁQUINA EN ESTUCHES METÁLICOS

Plus



Ref. JMPT2

## CONTENIDO

	FORMA B	BRILLANTE	 35°	BRILLANTE	 HSSCo 5%	HSS PM €		TiN €
JMP6	M3 - M4 - M5 - M6 M8 - M10 - M12		-		-	102,33	JMPT6	147,59
JMP2	M3 - M4 - M5 - M6 M8 - M10 - M12		-		2.5 / 3.3 / 4.2 / 5.0 6.8 / 8.5 / 10.2 mm	134,19	JMPT2	179,58
JMP8	-		M3 - M4 - M5 - M6 M8 - M10 - M12		-	147,59	JMPT8	162,55
JMP4	-		M3 - M4 - M5 - M6 M8 - M10 - M12		2.5 / 3.3 / 4.2 / 5.0 6.8 / 8.5 / 10.2 mm	179,58	JMPT4	194,64



INOX

## CONTENIDO

	FORMA B	OX	 35°	OX	 HSSCo 5%	HSS PM €		TiN €
JMX6	M3 - M4 - M5 - M6 M8 - M10 - M12		-		-	132,02	JMXT6	144,01
JMX2	M3 - M4 - M5 - M6 M8 - M10 - M12		-		2.5 / 3.3 / 4.2 / 5.0 6.8 / 8.5 / 10.2 mm	164,01	JMXT2	176,01
JMX8	-		M3 - M4 - M5 - M6 M8 - M10 - M12		-	150,66	JMXT8	166,09
JMX4	-		M3 - M4 - M5 - M6 M8 - M10 - M12		2.5 / 3.3 / 4.2 / 5.0 6.8 / 8.5 / 10.2 mm	182,64	JMXT4	198,07

  
1200  
N/mm<sup>2</sup>

## CONTENIDO

	FORMA B	OX	 35°	OX	 HSSCo 5%	HSS V3 €		TINALOX €
JMMD6	M3 - M4 - M5 - M6 M8 - M10 - M12		-		-	120,00	JMMDT6	170,37
JMMD2	M3 - M4 - M5 - M6 M8 - M10 - M12		-		2.5 / 3.3 / 4.2 / 5.0 6.8 / 8.5 / 10.2 mm	151,99	JMMDT2	202,35
JMMD8	-		M3 - M4 - M5 - M6 M8 - M10 - M12		-	136,95	JMMDT8	196,45
JMMD4	-		M3 - M4 - M5 - M6 M8 - M10 - M12		2.5 / 3.3 / 4.2 / 5.0 6.8 / 8.5 / 10.2 mm	168,94	JMMDT4	228,43

**MACHOS DE MÁQUINA EN ESTUCHES METÁLICOS**



Ref. JMC2

**CONTENIDO**

	FORMA B	TiCN	15°	TiCN	HSSCo 5%	HSS-PM €
JMC6	M3 - M4 - M5 - M6 M8 - M10 - M12		-		-	204,14
JMC2	M3 - M4 - M5 - M6 M8 - M10 - M12		-		2.5 / 3.3 / 4.2 / 5.0 6.8 / 8.5 / 10.2 mm	236,13
JMC8	-		M3 - M4 - M5 - M6 M8 - M10 - M12		-	232,36
JMC4	-		M3 - M4 - M5 - M6 M8 - M10 - M12		2.5 / 3.3 / 4.2 / 5.0 6.8 / 8.5 / 10.2 mm	264,35

**TODO TERRENO**

**CONTENIDO**

	FORMA B	TiN	35°	TiN	HSSCo 5%	HSS Co 5% €
JMD6	M3 - M4 - M5 - M6 M8 - M10 - M12		-		-	184,48
JMD2	M3 - M4 - M5 - M6 M8 - M10 - M12		-		2.5 / 3.3 / 4.2 / 5.0 6.8 / 8.5 / 10.2 mm	216,46
JMD8	-		M3 - M4 - M5 - M6 M8 - M10 - M12		-	208,03
JMD4	-		M3 - M4 - M5 - M6 M8 - M10 - M12		2.5 / 3.3 / 4.2 / 5.0 6.8 / 8.5 / 10.2 mm	240,02

**AI**

**CONTENIDO**

	DIENTE ALTERNO	BRILLANTE	2 CANALES	BRILLANTE	HSS	HSS Co 5% €
JMAL6	M3 - M4 - M5 - M6 M8 - M10 - M12		-		-	146,06
JMAL2	M3 - M4 - M5 - M6 M8 - M10 - M12		-		2.5 / 3.3 / 4.2 / 5.0 6.8 / 8.5 / 10.2 mm	178,05
JMAL8	-		M3 - M4 - M5 - M6 M8 - M10 - M12		-	144,43
JMAL4	-		M3 - M4 - M5 - M6 M8 - M10 - M12		2.5 / 3.3 / 4.2 / 5.0 6.8 / 8.5 / 10.2 mm	176,42

**MACHOS DE MÁQUINA EN ESTUCHES**
**USO  
GENERAL**
**CONTENIDO**

	FORMA B	BRILLANTE	 35°	BRILLANTE	HSS Co 5%
PT01	M4 - M5 - M6 M8 - M10		M4 - M5 - M6 M8 - M10		112,03 €



Ref. PT01

**Plus**
**CONTENIDO**

	FORMA B	BRILLANTE	 35°	BRILLANTE	HSS PM		TiN
PT02	M4 - M5 - M6 M8 - M10		M4 - M5 - M6 M8 - M10		140,93 €	PT03	206,96 €



Ref. PT03

**INOX**
**CONTENIDO**

	FORMA B	OX	 35°	OX	HSS PM		TiN
PT05	M4 - M5 - M6 M8 - M10		M4 - M5 - M6 M8 - M10		185,17 €	PT13	197,06 €



Ref. PT05

**CONTENIDO**

	FORMA B	OX	 35°	OX	HSS V3		TINALOX
PT04	M4 - M5 - M6 M8 - M10		M4 - M5 - M6 M8 - M10		158,92 €	PT14	238,82 €



Ref. PT04

**CONTENIDO**

	FORMA B	TiCN	 15°	TiCN	HSS PM
PT11	M4 - M5 - M6 M8 - M10		M4 - M5 - M6 M8 - M10		287,90 €



Ref. PT11



**MACHOS DE MÁQUINA EN ESTUCHES**



Ref. PT06

**CONTENIDO**

	DIENTE ALTERNO	2 CANALES	HSS Co 5% €
PT06	M4 - M5 - M6 M8 - M10	M4 - M5 - M6 M8 - M10	175,69



Ref. PT07

**CONTENIDO**

	FORMA C	HSS Co 5% €
PT07	M4 - M5 - M6 - M8 - M10 M4 - M5 - M6 - M8 - M10	132,78



Ref. PT10

**CONTENIDO**

	FORMA C	HSS Co 5% €
PT10	M4 - M5 - M6 - M8 - M10 M4 - M5 - M6 - M8 - M10	161,40



Ref. PT08

**CONTENIDO**

	LAMINACIÓN	HSS Co 5% €
PT08	M4 - M5 - M6 - M8 - M10 M4 - M5 - M6 - M8 - M10	243,01



Ref. PT09

**CONTENIDO**

		HSS Co 5% €
PT09	M4 - M5 - M6 - M8 - M10 M4 - M5 - M6 - M8 - M10	327,38



Ref. PT12

**CONTENIDO**

	FORMA B	35°	HSS Co 5% €
PT12	M4 - M5 - M6 M8 - M10	M4 - M5 - M6 M8 - M10	181,54

**EXPOSITORES DE METACRILATO PARA MACHOS DE MÁQUINA**
**EXPOSITOR DE METACRILATO**

MM-03

Composición: Machos de máquina, Serie Normal

**HSSCo**  
**5%**
**FORMA**

Agujeros pasantes, Ref. M2

<b>B</b>	<u>M4</u>	<u>M5</u>	<u>M6</u>	<u>M8</u>	<u>M10</u>	<u>M12</u>	<u>M14</u>
	5	10	10	10	10	5	4



35°

Agujeros ciegos, Ref. M4

	<u>M4</u>	<u>M5</u>	<u>M6</u>	<u>M8</u>	<u>M10</u>	<u>M12</u>	<u>M14</u>
	5	10	10	10	10	5	4

Dimensiones: ancho 240 x fondo 240 x alto 245 mm

1.522,29 €



Ref. MM-03



Ref. MM-04

**EXPOSITOR DE METACRILATO**

MM-04

Composición: Machos de máquina, Serie Plus  
Fabricados en Acero sinterizado PM
**HSS**  
**PM**

Plus

**FORMA**

Agujeros pasantes, Ref. M2

<b>B</b>	<u>M4</u>	<u>M5</u>	<u>M6</u>	<u>M8</u>	<u>M10</u>	<u>M12</u>	<u>M14</u>
	5	10	10	10	10	5	4



35°

Agujeros ciegos, Ref. M4

	<u>M4</u>	<u>M5</u>	<u>M6</u>	<u>M8</u>	<u>M10</u>	<u>M12</u>	<u>M14</u>
	5	10	10	10	10	5	4

Dimensiones: ancho 240 x fondo 240 x alto 245 mm

2.077,06 €

**EXPOSITOR DE METACRILATO**

MM-05

Composición: Machos de máquina para trabajos especiales

**FORMA**

B

Agujeros pasantes, Ref. M2

1200  
N/mm<sup>2</sup>

	<u>M4</u>	<u>M5</u>	<u>M6</u>	<u>M8</u>	<u>M10</u>	<u>M12</u>	<u>M14</u>
	1	2	2	2	2	1	1



INOX

	<u>M4</u>	<u>M5</u>	<u>M6</u>	<u>M8</u>	<u>M10</u>	<u>M12</u>	<u>M14</u>
	1	2	2	2	2	1	1



AI

	<u>M4</u>	<u>M5</u>	<u>M6</u>	<u>M8</u>	<u>M10</u>	<u>M12</u>	<u>M14</u>
	1	2	2	2	2	1	1



TiN

	<u>M4</u>	<u>M5</u>	<u>M6</u>	<u>M8</u>	<u>M10</u>	<u>M12</u>	<u>M14</u>
	1	2	2	2	2	1	1

1400  
N/mm<sup>2</sup>

	<u>M4</u>	<u>M5</u>	<u>M6</u>	<u>M8</u>	<u>M10</u>	<u>M12</u>	
	1	2	2	2	2	1	



35°

Agujeros ciegos, Ref. M4

1200  
N/mm<sup>2</sup>

	<u>M4</u>	<u>M5</u>	<u>M6</u>	<u>M8</u>	<u>M10</u>	<u>M12</u>	<u>M14</u>
	1	2	2	2	2	1	1



INOX

	<u>M4</u>	<u>M5</u>	<u>M6</u>	<u>M8</u>	<u>M10</u>	<u>M12</u>	<u>M14</u>
	1	2	2	2	2	1	1



AI

	<u>M4</u>	<u>M5</u>	<u>M6</u>	<u>M8</u>	<u>M10</u>	<u>M12</u>	<u>M14</u>
	1	2	2	2	2	1	1



TiN

	<u>M4</u>	<u>M5</u>	<u>M6</u>	<u>M8</u>	<u>M10</u>	<u>M12</u>	<u>M14</u>
	1	2	2	2	2	1	1

1400  
N/mm<sup>2</sup>

	<u>M4</u>	<u>M5</u>	<u>M6</u>	<u>M8</u>	<u>M10</u>	<u>M12</u>	
	1	2	2	2	2	1	

Dimensiones: ancho 240 x fondo 240 x alto 245 mm

2.495,93 €