

FRESAS

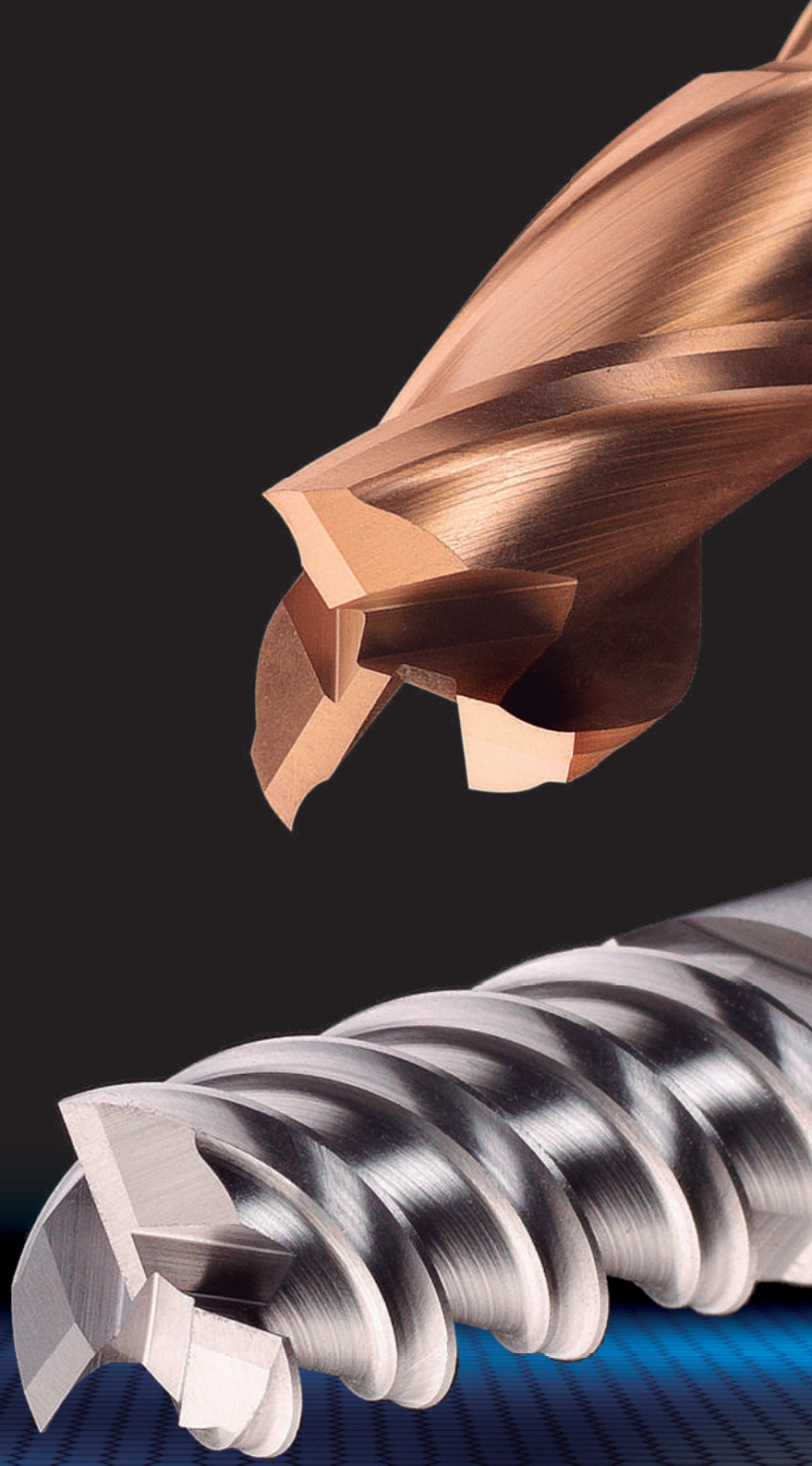

FRESAS FRONTALES SERIE CORTA DE 2 CORTES DIN 327 Y DIN 844

Fresas

Rosa

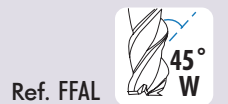
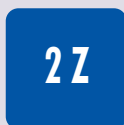

SERIE CORTA

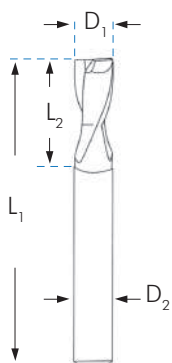

DIN 327	MATERIAL				FF01	FF02	FF60	FT02	FF92	FP05	FT12	FP08	FT01	DIN 844	FFAL
	ACABADO				HSS	HSSCo 8%	HSSCo 8%	HSSCo 8%	HSSCo 8%	ASP 60	ASP 60	ASP 60	ASP 60		HSSCo 8%
	CALIDAD				BRILLANTE	BRILLANTE	TiAIN	TiAISIN	BRILLANTE	BRILLANTE	TiAISIN	BRILLANTE	TiAISIN		BRILLANTE
D1	L1	L2	D2	TOL e8	TOL e8	TOL e8	TOL e8	TOL h10	TOL e8	TOL e8	TOL h10	TOL h10	TOL e8	TOL e8	
mm	mm	mm	mm	€	€	€	€	€	€	€	€	€	€	€	
1,00	47	2,5	6							19,89	26,00	29,00	34,93		
2,00	48	4,0	6	9,29	11,77	19,31	22,10	23,97	16,78	23,11	25,60	31,76		14,25	
2,50	49	5,0	6		11,77	19,31	22,10	25,50						14,14	
3,00	49	5,0	6	9,29	11,77	19,31	22,10	24,10	16,78	23,11	25,60	31,76		13,83	
3,50	50	6,0	6		12,78	20,31	23,23	25,50						14,68	
4,00	51	7,0	6	9,11	11,77	19,32	22,11	24,10	15,26	22,09	25,60	31,76		14,25	
4,50	52	8,0	6		14,07	21,43	24,53	25,50						15,58	
5,00	52	8,0	6	9,11	11,77	19,32	22,11	24,10	15,26	22,09	25,60	31,76		14,25	
5,50	52	8,0	6		14,55	21,99	25,16	25,50						17,44	
6,00	52	8,0	6	9,11	11,77	19,32	22,11	24,10	15,26	22,09	25,60	31,76		15,44	
6,50	60	10,0	10		19,05	27,55	31,53							22,82	
7,00	60	10,0	10	13,61	18,48	26,97	30,87	29,03	23,02	30,56	33,87	45,20		20,75	
7,50	61	11,0	10		18,31	26,80	30,67							24,32	
8,00	61	11,0	10	11,07	15,23	23,82	27,28	25,85	19,99	29,96	33,87	45,20		18,77	
8,50	61	11,0	10		20,57	29,80	34,11							25,64	
9,00	61	11,0	10	14,14	18,81	28,17	32,24	29,72	24,61	33,00	33,87	46,57		23,25	
9,50	63	13,0	10	15,48	20,12	29,16	33,36								
10,00	63	13,0	10	11,64	15,12	24,54	28,22	25,64	22,27	30,52	33,87	46,57		20,30	
10,50	70	13,0	12		24,17	36,71	41,42								
11,00	70	13,0	12		22,95	33,59	38,44	36,21						28,02	
12,00	73	16,0	12	15,20	20,25	30,75	35,20	34,19	28,41	39,40	46,12	59,18		25,45	
13,00	73	16,0	12		29,54	41,41	47,40	45,16						36,28	
14,00	73	16,0	12	21,63	29,54	41,41	47,40	45,16	34,63	48,31	52,12	65,48		35,61	
15,00	73	16,0	12		33,03	46,91	53,71	48,57						39,11	
16,00	79	19,0	16	22,59	29,23	43,06	49,29	49,35	43,35	57,27	60,94	76,41		38,10	
17,00	79	19,0	16		39,68	54,97	62,92							53,01	
18,00	79	19,0	16	29,58	39,68	55,03	62,99	60,10	54,90	68,30	77,25	117,76		47,60	
19,00	79	19,0	16		49,58	66,64	76,28							64,19	
20,00	88	22,0	16		46,94	64,12	73,40								
20,00	88	22,0	20	34,67	46,94	64,12	73,40	71,78	64,68	82,16	90,05	120,28		55,02	
22,00	88	22,0	20	47,57	62,00	84,98	97,26	93,92	82,37	115,24	106,93	138,13		76,60	
24,00	102	26,0	25	59,69	80,01	105,51	120,76	112,25						115,10	
25,00	102	26,0	25	59,70	77,94	101,18	115,80	103,15	109,98	138,85	140,19	174,80		97,49	
26,00	102	26,0	25		91,43	140,10	158,10							153,09	
28,00	102	26,0	25	74,79	98,43	131,29	150,99							118,62	
30,00	102	26,0	25	86,06	112,14	145,34	166,34	149,39						136,51	
32,00	112	32,0	32	89,24	115,20	148,01	169,40							144,59	
36,00	112	32,0	32	114,89	154,09	190,13	217,61								
40,00	130	38,0	40	139,68	189,21	235,07	269,05								

FRESAS FRONTALES SERIE LARGA DE 2 CORTES DIN 327 Y DIN 844/L

2Z



INOX
Al
TOL D₂
h6
Ref. FFLAL

SERIE LARGA



DIN 327/L				MATERIAL ACABADO CALIDAD					DIN 844/L			FFLAL	
				FF06	FF67	FT06	FF15	FP21					HSSCo 8% BRILLANTE **
D ₁ mm	L ₁ mm	L ₂ mm	D ₂ mm	TOL e8	TOL e8	TOL e8	TOL h10	TOL h10	TOL h10	L ₁ mm	L ₂ mm	D ₂ mm	€
2,00	54	7	6	12,97	20,48	23,43	26,36	30,06		54	10	6	20,90
2,50	56	8	6	13,05	20,48	23,43	26,39			56	12	6	
3,00	56	8	6	12,97	20,52	23,49	26,39	30,99		56	12	6	21,00
3,50	59	10	6	14,74	24,38	27,92				59	15	6	
4,00	63	11	6	13,04	20,52	23,49	26,39	30,99		63	19	6	21,14
4,50	63	11	6	14,74	20,96	23,99				63	19	6	
5,00	68	13	6	13,04	20,52	23,49	27,94	32,80		68	24	6	21,23
5,50	68	13	6	14,74	24,38	27,92				68	24	6	
6,00	68	13	6	13,04	20,52	23,49	25,24	29,63		68	24	6	22,04
6,50	80	16	10	24,45	40,01	45,15				68	24	6	
7,00	80	16	10	21,53	30,05	34,40	31,84	37,02		80	30	10	31,76
7,50	88	19	10							80	30	10	
8,00	88	19	10	18,94	27,44	31,43	31,84	37,38		88	38	10	30,12
8,50	88	19	10	29,00	39,46	45,16				88	38	10	
9,00	88	19	10	25,49	34,76	39,76	34,93	40,64		88	38	10	31,76
10,00	95	22	10	20,87	31,78	36,37	34,79	41,02		95	45	10	30,12
11,00	102	22	12	32,91	44,38	50,80	46,33			102	45	12	42,21
12,00	110	26	12	30,01	41,97	48,05	45,43	53,09		110	53	12	38,97
13,00	110	26	12							110	53	12	49,54
14,00	110	26	12	39,55	51,30	58,72	60,28	66,55		110	53	12	44,59
15,00	123	32	16							110	53	12	56,97
16,00	123	32	16	45,33	63,32	72,47	68,62	79,41		123	63	16	54,44
17,00	123	32	16							123	63	16	
18,00	123	32	16	51,80	74,31	85,04	82,46	95,42		123	63	16	67,38
20,00	141	38	20	59,57	81,52	93,30	89,41	103,46		141	75	20	80,37
22,00	141	38	20	81,66	110,62	126,60	110,82	128,27		141	75	20	
24,00	166	45	25	124,28	140,73	158,81	149,09			166	90	25	
25,00	166	45	25	117,15	148,85	170,36	136,30	157,74		166	90	25	
26,00	166	45	25	155,56	165,72	187,01				166	90	25	
28,00	166	45	25	141,96	181,22	207,42				166	90	25	
30,00	166	45	25	157,82	195,08	223,27	203,05			166	90	25	
32,00	186	53	32	218,34	254,30	291,05	264,57			186	106	32	
36,00	186	53	32	247,02	289,14	330,93				186	106	32	
40,00	196	63	32	323,69	390,65	447,12				196	125	40	





Fresas

Rosa

FRESAS FRONTALES SERIE CORTA DE 3 CORTES DIN 844 Y DIN 327

Fresas

Rosa

3Z   **WELDON**  **34 HRc** **INOX** **Al** **TOL D2 h6** 

SERIE CORTA

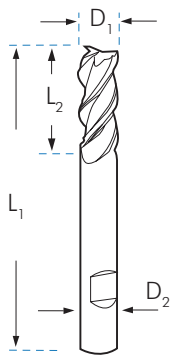

DIN 844	MATERIAL ACABADO CALIDAD DESBASTE				FF63	FF75	FT63	FF73	FF76	FT73	DIN 327			FP06	FT03
					HSSCo 8% BRILLANTE ★★ TOL k10	HSSCo 8% TiAlN ★★★ TOL k10	HSSCo 8% TiAlSiN ★★★★ TOL k10	HSSCo 8% BRILLANTE ★★ TOL k12	HSSCo 8% TiAlN ★★★ TOL k12	HSSCo 8% TiAlSiN ★★★★ TOL k12				ASP 60 BRILLANTE Premium Quality TOL e8	ASP 60 TiAlSiN Premium Quality TOL e8
	D1 mm	L1 mm	L2 mm	D2 mm	€	€	€	€	€	€	L1 mm	L2 mm	D2 mm	€	€
1,00	49	3	6								47	2,5	6	20,45	25,70
2,00	51	7	6	12,95	20,37	23,31					48	4,0	6	16,61	25,11
2,50	52	8	6	12,95	20,37	23,31					49	5,0	6		
3,00	52	8	6	12,90	20,37	23,31					49	5,0	6	16,61	25,11
3,50	55	11	6	13,34	20,75	23,87					50	6,0	6		
4,00	55	11	6	12,94	20,37	23,31					51	7,0	6	16,61	25,11
4,50	57	13	6	14,25	21,53	24,64					52	8,0	6		
5,00	57	13	6	12,94	20,46	23,43					52	8,0	6	16,61	25,11
5,50	57	13	6	17,59	28,00	32,05					52	8,0	6		
6,00	57	13	6	13,62	22,88	26,19	36,93	44,59	50,32		52	8,0	6	16,61	25,11
6,50	66	16	10	24,42	37,45	42,27					60	10,0	10		
7,00	66	16	10	19,03	27,50	31,62	43,67	53,24	60,07		60	10,0	10	22,37	30,60
7,50	69	19	10	24,60	37,85	42,72					61	11,0	10		
8,00	69	19	10	17,00	25,39	29,06	37,84	44,08	50,45		61	11,0	10	22,37	30,60
8,50	69	19	10	25,94	39,09	44,11					61	11,0	10		
9,00	69	19	10	21,23	30,44	34,84	44,91	52,71	60,32		61	11,0	10	26,22	33,69
9,50	72	22	10	28,02	41,08	46,35					63	13,0	10		
10,00	72	22	10	18,42	27,55	31,53	38,06	46,85	53,61		63	13,0	10	23,71	31,65
11,00	79	22	12	29,24	43,49	49,09	54,95	63,29	72,45		70	13,0	12		
12,00	83	26	12	23,12	32,89	37,64	45,80	53,92	61,71		73	16,0	12	30,59	40,03
13,00	83	26	12	36,77	50,57	57,08	59,84	69,70	79,79		73	16,0	12		
14,00	83	26	12	31,50	43,14	49,38	52,27	61,50	70,40		73	16,0	12	39,63	48,74
15,00	83	26	12	37,78	52,48	59,23	66,16	72,42	78,35		73	16,0	12		
16,00	92	32	16	34,59	48,14	55,10	63,36	76,42	87,49		79	19,0	16	46,61	56,11
17,00	92	32	16	56,61	74,32	83,86					79	19,0	16		
18,00	92	32	16	43,45	58,78	67,27	69,33	84,13	96,29		79	19,0	16	57,35	68,63
19,00	92	31	16	69,22	85,51	96,51					79	19,0	16		
20,00	104	38	20	49,90	66,26	75,84	84,59	98,95	113,26		88	22,0	20	68,21	82,16
22,00	104	38	20	79,55	100,03	112,90					88	22,0	20	91,05	117,55
25,00	121	45	25	103,93	132,45	149,48	128,13	146,42	167,59		102	26,0	25	114,30	132,55
28,00	121	45	25	120,73	148,10	167,13					102	26,0	25		
30,00	121	45	25	148,52	173,94	196,30	159,34	188,00	215,19		102	26,0	25		
32,00	133	53	32	151,17	187,73	211,85					112	32,0	32		

FRESAS FRONTALES SERIE LARGA DE 3 CORTES DIN 844/L

3 Z



SERIE LARGA

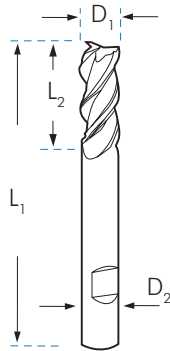

DIN 844/L		MATERIAL		FF83	FF86	FT83
		ACABADO		HSSCo 8%	HSSCo 8%	HSSCo 8%
		CALIDAD		BRILLANTE	TiAIN	TiAlSiN
				★★	★★★	★★★★
D1	L1	L2	D2	€	€	€
mm	mm	mm	mm			
1,00	52	7	6			
2,00	54	10	6	17,44	25,54	29,22
2,50	56	12	6	17,78	25,50	29,19
3,00	56	12	6	17,44	25,46	29,14
3,50	59	15	6	19,52	27,30	31,25
4,00	63	19	6	17,44	25,46	29,14
4,50	63	19	6	19,52	27,30	31,25
5,00	68	24	6	17,44	25,46	29,14
5,50	68	24	6	19,52	27,30	31,25
6,00	68	24	6	19,55	26,63	30,48
6,50	68	24	6			
7,00	80	30	10	26,47	35,65	40,80
7,50	80	30	10			
8,00	88	38	10	24,21	32,16	36,80
8,50	88	38	10			
9,00	88	38	10	29,47	38,15	43,67
9,50	88	38	10			
10,00	95	45	10	24,35	35,36	40,48
11,00	102	45	12	37,43	48,16	55,13
12,00	110	53	12	30,99	43,11	49,35
13,00	110	53	12			
14,00	110	53	12	40,35	52,72	60,34
15,00	110	53	12			
16,00	123	63	16	45,47	63,54	72,73
17,00	123	63	16			
18,00	123	63	16	55,09	75,12	85,97
19,00	123	63	16			
20,00	141	75	20	64,67	85,94	98,36
22,00	141	75	20	81,56	110,82	126,84
25,00	166	90	25	118,88	146,40	167,57
28,00	166	90	25	132,34	175,32	200,68
30,00	166	90	25	147,34	187,28	214,35
32,00	186	106	32	175,31	210,91	241,42

FRESAS FRONTALES SERIE CORTA Y LARGA VARIOS CORTES DIN 844 Y DIN 844/L

Fresas

Rosa

4-6 Z



INOX

Al

**TOL D1
k10**

**TOL D2
h6**





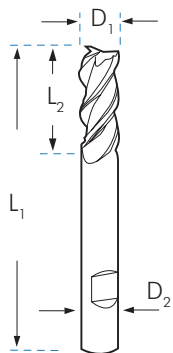

SERIE CORTA

SERIE LARGA



DIN 844		MATERIAL		ACABADO		CALIDAD		FF18	FF20	FT18	FP07	FT09	DIN 844/L		MATERIAL		ACABADO		CALIDAD		FF21	FF23	FT21	FP20
D1	L1	L2	D2	Z	HSSCo 8%	HSSCo 8%	HSSCo 8%	HSSCo 8%	HSSCo 8%	HSSCo 8%	ASP 60	ASP 60	L1	L2	D2	Z	HSSCo 8%	HSSCo 8%	HSSCo 8%	ASP 60	HSSCo 8%	HSSCo 8%	HSSCo 8%	ASP 60
mm	mm	mm	mm		BRILLANTE	TiAIN	TiAISIN	BRILLANTE	TiAISIN	BRILLANTE	TiAISIN	BRILLANTE	mm	mm	mm		BRILLANTE	TiAIN	TiAISIN	BRILLANTE	BRILLANTE	TiAIN	TiAISIN	BRILLANTE
					★★	★★★	★★★★	★★★★	★★★★	★★★★	Premium Quality	Premium Quality					★★	★★★	★★★★	★★★★	★★★★	★★★★	Premium Quality	Premium Quality
€	€	€	€	€	€	€	€	€	€	€	€	€	€	€	€	€	€	€	€	€	€	€	€	€
1,00	49	3	6	4							22,67	27,17	52	7	6	4								
2,00	51	7	6	4	12,98	20,42	23,37	16,57	22,92				54	10	6	4	15,84	23,19	26,54	24,61				
2,50	52	8	6	4	12,98	20,42	23,37	16,57	22,92				56	12	6	4	15,76	23,19	26,54	24,61				
3,00	52	8	6	4	12,98	20,42	23,37	16,57	22,92				56	12	6	4	15,84	23,21	26,55	24,61				
3,50	55	11	6	4	13,37	20,80	23,82						59	15	6	4	20,83	28,13	32,18					
4,00	55	11	6	4	12,98	20,42	23,37	16,57	22,92				63	19	6	4	15,84	23,21	26,55	24,61				
4,50	57	13	6	4	14,27	21,57	24,68						63	19	6	4	20,83	28,13	32,18					
5,00	57	13	6	4	12,98	20,42	23,37	16,57	22,92				68	24	6	4	15,84	23,21	26,55	24,61				
5,50	57	13	6	4	20,76	28,00	32,05						68	24	6	4	20,70	28,13	32,18					
6,00	57	13	6	4	13,55	21,06	24,10	16,57	22,92				68	24	6	4	15,84	23,21	26,55	24,61				
6,50	66	16	10	4	20,71	29,15	33,36						68	24	6	4								
7,00	66	16	10	4	19,03	27,51	31,48	22,52	32,71				80	30	10	4	24,05	32,27	36,94	36,72				
7,50	69	16	10	4	24,53	32,75	37,49						80	30	10	4								
8,00	69	19	10	4	16,75	25,49	29,18	22,42	32,38				88	38	10	4	21,84	29,07	33,27	36,72				
8,50	69	19	10	4	25,58	34,63	39,65						88	38	10	4								
9,00	69	19	10	4	21,14	30,48	34,89	26,49	35,32				88	38	10	4	24,89	33,89	38,80	36,72				
9,50	69	19	10	4	27,06	36,03	41,23						88	38	10	4								
10,00	72	22	10	4	18,32	27,67	31,68	23,81	33,19				95	45	10	4	21,93	32,09	36,73	36,72				
11,00	79	22	12	4	25,48	36,00	41,21						102	45	12	4	31,17	42,28	48,41					
12,00	83	26	12	4	23,12	31,98	36,61	31,45	43,95				110	53	12	4	28,71	40,16	45,98	53,24				
13,00	83	26	12	4	32,61	44,48	50,91						110	53	12	4								
14,00	83	26	12	4	30,79	43,40	49,68	40,86	48,94				110	53	12	4	37,57	48,97	56,06	61,45				
15,00	83	26	12	4	35,15	48,50	55,51						110	53	12	4								
16,00	92	32	16	4	34,30	48,37	55,36	47,88	57,97				123	63	16	4	41,07	57,61	65,95	76,15				
17,00	92	32	16	4	42,75	57,93	66,30						123	63	16	4								
18,00	92	32	16	4	42,25	58,84	67,34	58,39	72,50				123	63	16	4	50,16	68,59	78,50	97,43				
19,00	92	31	16	4	50,04	66,58	76,20						123	63	16	4								
20,00	104	38	20	4	49,48	66,58	76,20	68,68	94,19				141	75	20	4	58,75	79,22	90,68	119,48				
22,00	104	38	20	5	68,67	92,30	105,64	90,50	111,08				141	75	20	5	81,46	104,41	119,52	134,01				
24,00	121	45	25	5	86,33	108,76	124,48						141	75	25	5								
25,00	121	45	25	5	82,52	108,24	123,90	116,76	146,49				166	90	25	5	108,01	133,35	152,62	194,67				
26,00	121	45	25	5	99,06	131,40	152,57						166	90	25	5								
28,00	121	45	25	5	98,23	131,69	155,89						166	90	25	5	120,81	158,63	181,56					
30,00	121	45	25	6	114,19	146,17	175,63						166	90	25	6	136,36	174,27	199,47					
32,00	133	53	32	6	117,08	149,54	179,68						186	106	32	6	137,48	175,50	200,87					
36,00	133	53	32	6	156,03	188,93	226,98						186	106	32	6	197,05	236,59	270,77					
40,00	155	63	32	6	187,57	229,75	276,05						217	125	32	6	218,41	282,07	324,39					

FRESAS FRONTALES DE DESBASTE VARIOS CORTES DIN 844 Y DIN 844/L

4-6 Z   **30° N**  **WELDON**  **34 HRC** **INOX** **Al** **TOL D1 k12** **TOL D2 h6**

SERIE CORTA

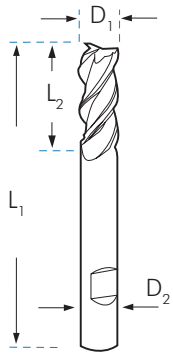

SERIE LARGA



DIN 844					MATERIAL	FF25	FF27	FT25
					ACABADO	HSSCo 8%	HSSCo 8%	HSSCo 8%
					CALIDAD	BRILLANTE	TiAIN	TiAISIN
					DESBASTE	★★	★★★	★★★★
						NR	NR	NR
D1 mm	L1 mm	L2 mm	D2 mm	Z	€	€	€	
2,00	51	7	6	3				
2,50	52	8	6	3				
3,00	52	8	6	3				
3,50	55	11	6	3				
4,00	55	11	6	3				
4,50	57	13	6	3				
5,00	57	13	6	3				
5,50	57	13	6	3				
6,00	57	13	6	4	33,23	40,12	45,92	
6,50	66	16	10	4				
7,00	66	16	10	4	39,94	47,89	54,81	
7,50	69	19	10	4				
8,00	69	19	10	4	34,69	42,64	48,80	
8,50	69	19	10	4				
9,00	69	19	10	4	41,46	50,21	57,48	
10,00	72	22	10	4	34,42	42,23	48,32	
11,00	79	22	12	4	50,43	60,49	69,24	
12,00	83	26	12	4	41,57	51,48	58,92	
13,00	83	26	12	4	59,02	69,85	79,95	
14,00	83	26	12	4	48,26	59,70	68,34	
15,00	83	26	12	4	63,46	76,85	87,96	
16,00	92	32	16	4	57,25	70,36	80,54	
17,00	92	32	16	4	78,17	93,01	106,45	
18,00	92	32	16	4	62,42	77,52	88,73	
19,00	92	31	16	4	92,39	107,80	123,40	
20,00	104	38	20	4	78,23	94,69	108,38	

SIN CORTE AL CENTRO					FF05	FF74	FT05
22,00	104	38	20	6	88,38	114,26	
24,00	121	45	25	6	111,32	135,50	148,41
25,00	121	45	25	6	110,27	134,72	147,55
26,00	121	45	25	6	127,70	164,85	180,54
28,00	121	45	25	6	127,70	164,41	180,06
30,00	121	45	25	6	137,18	179,94	197,07
32,00	133	53	32	6	155,41	193,54	211,96
36,00	133	53	32	6	184,19	223,02	244,27
40,00	155	63	32	6	207,07	258,25	282,85

DIN 844/L					MATERIAL	FF29	FF31	FT29
					ACABADO	HSSCo 8%	HSSCo 8%	HSSCo 8%
					CALIDAD	BRILLANTE	TiAIN	TiAISIN
					DESBASTE	★★	★★★	★★★★
						NR	NR	NR
L1 mm	L2 mm	D2 mm	Z		€	€	€	
54	10	6	3					
56	12	6	3					
56	12	6	3					
59	15	6	3					
63	19	6	3					
63	19	6	3					
68	24	6	3					
68	24	6	3					
68	24	6	4		47,10	53,28	61,27	
68	24	6	4					
80	30	10	4		53,41	60,87	69,67	
80	30	10	4					
88	38	10	4		48,72	56,33	64,47	
88	38	10	4					
88	38	10	4		53,41	61,72	70,63	
95	45	10	4		42,42	52,46	60,05	
102	45	12	4		69,44	79,57	91,08	
110	53	12	4		52,41	63,41	72,58	
110	53	12	4					
110	53	12	4		60,55	71,64	82,01	
110	53	12	4					
123	63	16	4		70,89	86,93	99,49	
123	63	16	4					
123	63	16	4		82,78	101,65	116,34	
123	63	16	4					
141	75	20	4		100,76	119,84	137,16	

					FF08	FF58	FT08
141	75	20	6		113,49	153,08	167,65
141	75	25	6				
166	90	25	6		143,33	181,35	198,62
166	90	25	6				
166	90	25	6		161,63	208,49	228,34
166	90	25	6		209,55	249,04	272,77
186	106	32	6		219,17	254,60	278,85
186	106	32	6		263,17	304,04	332,99
217	125	40	6		311,16	378,43	414,48









Fresas

Rosa

FRESAS FRONTALES, SIN CORTE AL CENTRO, VARIOS CORTES DIN 844 Y DIN 844/L

Fresas

Rosa

4-6 Z   **30° N**  **WELDON**  **34 HRc**  **INOX**  **Al**  **TOL D1 k10**  **TOL D2 h6** 

SERIE CORTA

SERIE LARGA

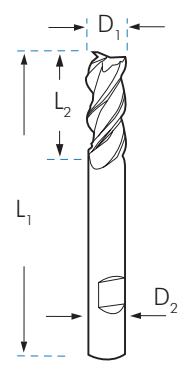

DIN 844		MATERIAL			FF03	FF04	FF54	FT04	DIN 844/L		MATERIAL			FF07	FF57	FT07
		ACABADO			HSS	HSSCo 8%	HSSCo 8%	HSSCo 8%			ACABADO			HSSCo 8%	HSSCo 8%	HSSCo 8%
		CALIDAD			BRILLANTE	BRILLANTE	TiAlN	TiAlSiN			CALIDAD			BRILLANTE	TiAlN	TiAlSiN
		★			★	★★	★★★	★★★★			★			★★	★★★	★★★★
D1	L1	L2	D2	Z	€	€	€	€	L1	L2	D2	Z	€	€	€	
mm	mm	mm	mm						mm	mm	mm					
2,00	51	7	6	4	9,30	12,20	19,62	22,47	54	10	6	4	15,25	23,60	27,14	
2,50	52	8	6	4	9,30	12,20	19,62	22,47	56	12	6	4	15,25	21,66	24,92	
3,00	52	8	6	4	9,30	12,20	19,62	22,47	56	12	6	4	15,25	24,55	28,23	
3,50	55	11	6	4	9,60	12,58	20,07	22,95	59	15	6	4	20,06	29,46	33,88	
4,00	55	11	6	4	9,30	12,20	19,70	22,53	63	19	6	4	15,25	24,55	28,23	
4,50	57	13	6	4	9,60	12,57	20,07	22,95	63	19	6	4	20,06	29,46	33,88	
5,00	57	13	6	4	9,30	12,20	19,70	22,53	68	24	6	4	15,25	24,55	28,23	
5,50	57	13	6	4	14,46	18,97	26,38	30,19	68	24	6	4	20,06	29,46	33,88	
6,00	57	13	6	4	9,30	12,20	19,69	22,52	68	24	6	4	15,25	24,55	28,23	
6,50	66	16	10	4	14,46	18,97	27,30	31,25	68	24	6	4				
7,00	66	16	10	4	13,64	17,91	26,30	30,10	80	30	10	4	23,08	33,87	38,96	
7,50	69	16	10	4	17,10	22,41	30,58	35,00	80	30	10	4				
8,00	69	19	10	4	10,61	13,76	22,30	25,53	88	38	10	4	21,18	31,92	36,70	
8,50	69	19	10	4	17,82	23,42	32,39	37,08	88	38	10	4				
9,00	69	19	10	4	14,27	18,71	27,94	31,98	88	38	10	4	23,96	35,72	41,09	
9,50	72	22	10	4	19,35	24,74	34,01	38,93	88	38	10	4				
10,00	72	22	10	4	12,96	16,97	26,32	30,12	95	45	10	4	21,07	33,97	39,07	
11,00	79	22	12	4	17,85	23,42	33,96	38,86	102	45	12	4	28,82	42,87	49,31	
12,00	83	26	12	4	15,39	20,25	30,54	34,95	110	53	12	4	26,76	40,77	46,89	
13,00	83	26	12	4	22,95	30,23	41,61	47,62	110	53	12	4				
14,00	83	26	12	4	21,71	28,41	40,03	45,80	110	53	12	4	34,99	49,47	56,89	
15,00	83	26	12	4	24,76	32,43	46,10	52,75	110	53	12	4				
16,00	92	32	16	4	24,15	31,64	45,34	51,89	123	63	16	4	38,24	58,47	67,25	
17,00	92	32	16	4	29,76	39,17	54,21	62,04	123	63	16	4				
18,00	92	32	16	4	29,72	39,00	54,21	62,04	123	63	16	4	46,70	69,48	79,89	
19,00	92	31	16	4	35,20	45,89	62,20	71,20	123	63	16	4				
20,00	104	38	20	4	34,84	45,89	62,20	71,20	141	75	20	4	54,69	79,74	91,70	
22,00	104	38	20	5	48,36	63,68	86,09	98,54	141	75	20	5	75,86	104,80	120,53	
24,00	121	45	25	5	60,07	79,13	101,20	115,84	141	75	25	5				
25,00	121	45	25	5	59,87	79,13	101,20	115,84	166	90	25	5	100,61	134,19	154,31	
26,00	121	45	25	5	75,10	98,92	127,93	146,42	166	90	25	5				
28,00	121	45	25	5	75,10	98,92	131,39	150,37	166	90	25	5	122,98	165,24	190,04	
30,00	121	45	25	6	87,06	114,03	146,51	167,70	166	90	25	6	140,75	183,19	210,66	
32,00	133	53	32	6	89,53	116,97	149,92	171,59	186	106	32	6	140,53	184,49	212,15	
36,00	133	53	32	6	117,17	154,31	187,72	214,85	186	106	32	6	200,42	253,48	291,51	
40,00	143	63	32	6	140,47	185,49	230,36	263,66	217	125	40	6	222,79	340,67	391,78	

FRESAS FRONTALES DE DESBASTE VARIOS CORTES DIN 844 Y DIN 844/L

3-5 Z



SERIE CORTA

SERIE LARGA

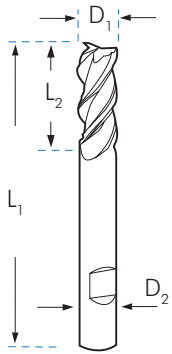

DIN 844	MATERIAL				Z	€	€	€	€
	ACABADO	DESBASTE	CALIDAD						
	ASP 60	NF	Premium Quality						
	BRILLANTE	NF	Premium Quality						
	TiAlSiN	NF	Premium Quality						
	BRILLANTE	NR	Premium Quality						
	TiAlSiN	NR	Premium Quality						
D1 mm	L1 mm	L2 mm	D2 mm						
2,00	51	7	6	3					
2,50	52	8	6	3					
3,00	52	8	6	3					
3,50	55	11	6	3					
4,00	55	11	6	3					
4,50	57	13	6	3					
5,00	57	13	6	3					
5,50	57	13	6	3					
6,00	57	13	6	3	40,48	46,88	37,51	40,57	
6,50	66	16	10	3					
7,00	66	16	10	3	51,90	57,04	47,09	54,09	
7,50	69	19	10	3					
8,00	69	19	10	3	44,71	52,54	40,98	47,79	
8,50	69	19	10	3					
9,00	69	19	10	3	53,84	59,50	48,98	56,55	
9,50	72	22	10	3					
10,00	72	22	10	4	42,62	50,99	38,64	48,43	
11,00	79	22	12	4					
12,00	83	26	12	4	56,07	64,09	51,12	59,04	
13,00	83	26	12	4					
14,00	83	26	12	4	68,09	78,13	61,73	70,85	
15,00	83	26	12	4					
16,00	92	32	16	4	83,46	92,89	76,10	86,54	
17,00	92	32	16	4					
18,00	92	32	16	4	91,64	101,00	82,58	94,66	
19,00	92	31	16	4					
20,00	104	38	16	4					
20,00	104	38	20	4	113,68	126,49	102,76	118,66	
22,00	104	38	20	5	140,14	155,83	127,09	145,78	
22,00	121	45	25	5					
24,00	121	45	25	5					
25,00	121	45	25	5	166,13	186,30	150,69	172,55	
26,00	121	45	25	5					
28,00	121	45	25	5					
30,00	121	45	25	5					
32,00	133	53	32	5					
36,00	133	53	32	5					
40,00	155	63	40	5					

DIN 844/L	MATERIAL				Z	€	€	€	€
	ACABADO	DESBASTE	CALIDAD						
	ASP 60	NF	Premium Quality						
	BRILLANTE	NF	Premium Quality						
	TiAlSiN	NF	Premium Quality						
	BRILLANTE	NR	Premium Quality						
	TiAlSiN	NR	Premium Quality						
L1 mm	L2 mm	D2 mm							
54	10	6	3						
56	12	6	3						
56	12	6	3						
59	15	6	3						
63	19	6	3						
63	19	6	3						
68	24	6	3						
68	24	6	3						
68	24	6	3		63,51	67,73	56,34	62,57	
68	24	6	3						
80	30	10	3		71,80	82,50	65,21	76,85	
80	30	10	3						
88	38	10	3		66,81	71,76	59,13	66,84	
88	38	10	3						
88	38	10	3		70,47	81,39	65,21	77,34	
88	38	10	3						
95	45	10	4		60,11	67,46	53,56	62,30	
102	45	12	4						
110	53	12	4		76,18	83,98	67,27	76,88	
110	53	12	4						
110	53	12	4		89,28	103,39	80,29	91,51	
110	53	12	4						
123	63	16	4		106,80	118,39	95,29	109,24	
123	63	16	4						
123	63	16	4		119,46	140,39	108,83	125,15	
123	63	16	4						
141	75	16	4						
141	75	20	4		155,27	171,91	137,57	159,84	
141	75	20	5		237,24	255,87	207,74	232,11	
141	75	25	5						
141	75	25	5						
166	90	25	5		238,22	263,98	210,14	246,00	
166	90	25	5						
166	90	25	5						
166	90	25	5						
186	106	32	5						
186	106	32	5						
217	125	40	5						

FRESAS SERIE SUPER CORTA Y EXTRA CORTA DE 3 CORTES

3 Z



INOX

Al

TOL D1
e8TOL D2
h6

SERIE SUPER CORTA



MATERIAL ACABADO					FF51 HSSCo 8% BRILLANTE
D1 mm	L1 mm	L2 mm	D2 mm	Z	€
1,00	34	2	6	3	12,41
1,50	34	3	6	3	12,41
2,00	35	4	6	3	12,40
2,50	36	5	6	3	12,40
3,00	36	5	6	3	12,40
3,50	37	6	6	3	12,40
4,00	38	7	6	3	12,40
4,50	38	7	6	3	12,40
5,00	39	8	6	3	12,40
5,50	39	8	6	3	12,40
6,00	39	8	6	3	12,40
6,50	42	10	8	3	17,04
7,00	42	10	8	3	17,04
7,50	42	10	8	3	17,04
8,00	43	11	8	3	17,04
8,50	48	11	10	3	19,53
9,00	48	11	10	3	19,53
9,50	48	11	10	3	19,53
10,00	50	13	10	3	19,53

SERIE EXTRA CORTA



MATERIAL ACABADO					FF53 HSSCo 8% BRILLANTE
D1 mm	L1 mm	L2 mm	D2 mm	Z	€
2,00	38	7	6	3	13,60
2,50	39	8	6	3	13,60
3,00	39	8	6	3	13,60
3,50	41	10	6	3	13,60
4,00	42	11	6	3	13,60
4,50	42	11	6	3	13,60
5,00	44	13	6	3	13,60
5,50	44	13	6	3	13,60
6,00	44	13	6	3	13,60
6,50	48	16	8	3	18,71
7,00	48	16	8	3	18,71
8,00	51	19	8	3	18,71
8,50	56	19	10	3	21,39
9,00	56	19	10	3	21,39
10,00	59	22	10	3	21,39

3-4 Z

DIN
844NHSS
PM

Al

Cu

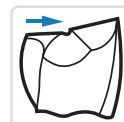
TOL D1
k10TOL D2
h6Mejora la
extracción de
viruta

	FP22					
	D1 mm	L1 mm	L2 mm	D2 mm	Z	€
FP220600	6,00	57	13	6	3	32,14
FP220700	7,00	66	16	10	3	43,42
FP220800	8,00	69	19	10	3	43,42
FP220900	9,00	69	19	10	3	43,42
FP221000	10,00	72	22	10	3	43,42
FP221200	12,00	83	26	12	3	59,77
FP221400	14,00	83	26	12	3	68,13
FP221500	15,00	83	26	12	3	83,22
FP221600	16,00	92	32	16	3	83,22
FP221800	18,00	92	32	16	3	116,67
FP222000	20,00	104	38	20	3	139,23

FRESAS DE METAL DURO PARA MATERIALES COMPUESTOS: FIBRA DE CARBONO, PANEL FENÓLICO, ETC...

MD



REVOLUCIONES Y AVANCES

D ₁ mm	RPM rev./min	AVANCE mm/min
1,50	60.000	3.000
2,00	50.000	2.500
3,00	32.000	1.600
5,00	20.000	1.200
6,00	16.000	1.000
6,35	14.000	1.000
8,00	9.000	700
10,00	7.000	550
12,00	6.000	450



D ₁ mm	L ₁ mm	L ₂ mm	D ₂ mm	RFC		RF		RFC TL		RF TL	
				€		€	TiAlN	€	TiAlN	€	
1,50	38	5	3,00	RFC0150	16,12	RF0150	15,28	RFC0150TL	24,36	RF0150TL	23,53
2,00	38	10	3,00	RFC0200	16,12	RF0200	15,28	RFC0200TL	24,36	RF0200TL	23,53
3,00	38	12	3,00	RFC0300	16,12	RF0300	15,28	RFC0300TL	24,36	RF0300TL	23,53
5,00	50	16	5,00	RFC0500	32,00	RF0500	29,06	RFC0500TL	40,26	RF0500TL	37,31
6,00	63	25	6,00	RFC0600	38,06	RF0600	34,51	RFC0600TL	48,08	RF0600TL	44,55
6,35	75	30	6,35	RFC0635	42,25	RF0635	38,69	RFC0635TL	52,32	RF0635TL	48,73
8,00	63	25	8,00	RFC0800	63,36	RF0800	57,52	RFC0800TL	72,85	RF0800TL	66,99
10,00	63	25	10,00	RFC1000	80,49	RF1000	73,19	RFC1000TL	90,46	RF1000TL	83,15
12,00	75	25	12,00	RFC1200	101,20	RF1200	92,03	RFC1200TL	113,53	RF1200TL	104,35

FRESA DE METAL DURO PARA REPARACIÓN DE PINCHAZOS

MD



	RN				
	D ₁ mm	L ₁ mm	L ₂ mm	D ₂ mm	€
RN0300	3,00	50	25	3	15,69
RN0600	6,00	80	50	6	37,86
RN0800	8,00	110	50	8	42,65
RN1000	10,00	110	60	10	66,93

FRESAS DE METAL DURO ACCESORIOS TIPO ROTOZIP



Ref.: RR0317



Ref.: RR0635



Ref.: RR0435



Ref.: RR0247



Ref.: RR0535

		RR				
		D ₁ mm	L ₁ mm	L ₂ mm	D ₂ mm	€
RR0317	Cortador Azulejo	3,17	50	25	3,17	18,09
RR0635	Cortador Azulejo	6,35	50	25	6,35	30,33
RR0435	Trabajos en Yeso	6,35	52	32	6,35	37,95
RR0247	Argamasa	2,47	38	14	3,17	13,29
RR0535*	Fresas para Chapa	6,35	50	10	6,35	16,01*

*Hasta fin de existencias

FRESAS DE 1 LABIO HSSCo

HSSCo

Al

PVC

TOL D1
k12TOL D2
h6
SERIE CORTA

FF13

	D1 mm	L1 mm	L2 mm	D2 mm	HSSCo €	TiN €
FF1381	1,0	60	12	8	36,31	53,00
FF1382	2,0	60	12	8	36,31	53,00
FF1383	3,0	60	12	8	14,33	20,92
FF1384	4,0	60	12	8	14,33	20,92
FF1385	5,0	60	13	8	14,33	20,92
FF1386	6,0	60	16	8	14,60	20,92
FF1387	7,0	60	16	8	17,49	24,59
FF1388	8,0	80	16	8	17,49	24,59
FF131010	10,0	80	15	10	18,72	24,59
FF1361	1,0	45	6	6	26,26	34,83
FF13615	1,5	45	6	6	26,26	34,83
FF1362	2,0	45	6	6	26,26	34,83
FF1363	3,0	60	12	6	13,60	19,08
FF1364	4,0	60	12	6	13,65	19,08
FF1365	5,0	60	12	6	13,65	19,08
FF1366	6,0	60	14	6	13,65	19,08

SERIE LARGA

FF14

	D1 mm	L1 mm	L2 mm	L3 mm	D2 mm	HSSCo €	TiN €
FF1483	3	80	16	45	8	23,80	30,21
FF1484	4	80	16	45	8	20,27	26,83
FF1485	5	80	16	45	8	20,27	26,83
FF1486	6	90	16	45	8	20,27	26,83
FF1487	7	90	20	50	8	26,24	33,09
FF1488	8	100	30	70	8	23,72	30,50
FF1465	5	80	14	45	6	20,25	26,83
FF1466	6	80	14	45	6	20,27	26,83

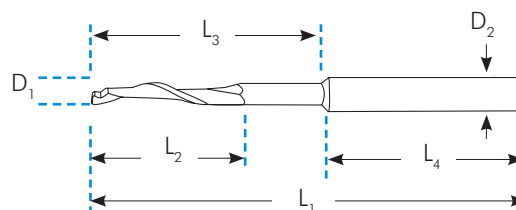
SERIE EXTRA LARGA

FF14-E

	D1 mm	L1 mm	L2 mm	L3 mm	D2 mm	L4 mm	HSSCo €	TiN €
FF14-E	5	100	30	55	8	45	19,16	25,75
FF14-EL	5	100	50	-	8	50	24,62	34,97

ALUMINIO LACADO

FF50

	D1 mm	L1 mm	L2 mm	L3 mm	D2 mm	HSSCo €	TiN €
FF5084	4	80	16	35	8	19,08	26,03
FF5085	5	80	18	35	8	19,08	26,03

MEDIDAS ESPECIALES

FF14 Especiales

	D1 mm	L1 mm	L2 mm	L3 mm	D2 mm	HSSCo €
FF148412020	4	120	20	-	8	21,19
FF14856018	5	60	18	-	8	17,46
FF14859025	5	90	25	-	8	22,79
FF148510025	5	100	25	-	8	21,18
FF148512014	5	120	14	-	8	21,18
FF14851001817	5	100	18	35	8	21,51
FF14851201461	5	120	14	75	8	28,98
FF14851201817	5	120	18	35	8	28,98
FF1486801421	6	80	14	35	8	24,01
FF14861001835	6	100	18	35	8	24,01
FF14861201461	6	120	14	75	8	34,72

FF14 Especiales

	D1 mm	L1 mm	L2 mm	L3 mm	D2 mm	HSSCo €
FF14861003045	6	100	30	45	8	29,12
FF14861006040	6	100	60	-	8	37,39
FF14888025	8	80	25	-	8	18,12
FF148810014	8	100	14	-	8	20,04
FF148812014	8	120	14	-	8	20,43
FF14881201476	8	120	14	90	8	26,26
FF14898014	9	80	14	-	8	21,02
FF148108014	10	80	14	-	8	22,38
FF1410101003040	10	100	30	70	10	27,31
FF1410101201481	10	120	14	95	10	27,31
FF14101012014	10	120	14	-	10	23,45
FF148128014	12	80	14	-	8	25,38

FRESAS DE 1 LABIO DE METAL DURO

MD **Al** PVC TOL h10 TOL D2 h6

HÉLICE A - SERIE CORTA



A	D1 mm	L1 mm	L2 mm	D2 mm	FMGA13	
					MD	€
FMGA13305	0,5	39	1,5	3	45,36	
FMGA1331	1,0	39	3,0	3	35,43	
FMGA13315	1,5	39	4,0	3	31,88	
FMGA1322	2,0	40	10,0	2	26,87	
FMGA1333	3,0	40	12,0	3	22,75	
FMGA1336	3,0	64	12,0	6	39,81	
FMGA1338	3,0	64	12,0	8	57,66	
FMGA1344	4,0	50	16,0	4	25,02	
FMGA1346	4,0	64	16,0	6	40,21	
FMGA1348	4,0	64	16,0	8	67,10	
FMGA135550	5,0	50	16,0	5	25,97	
FMGA1355	5,0	64	16,0	5	28,44	
FMGA1356	5,0	64	16,0	6	45,26	
FMGA1358	5,0	64	16,0	8	68,62	
FMGA136650	6,0	50	16,0	6	34,91	
FMGA1366	6,0	64	20,0	6	38,46	
FMGA1368	6,0	64	20,0	8	69,66	
FMGA1378	7,0	64	20,0	8	78,10	
FMGA138816	8,0	66	16,0	8	39,60	
FMGA1388	8,0	76	38,0	8	52,51	
FMGA131010	10,0	76	30,0	10	65,80	

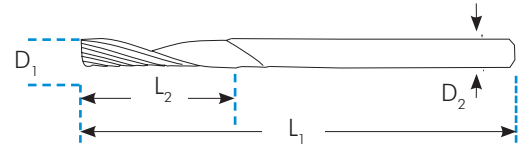

HÉLICE A - SERIE LARGA



A	D1 mm	L1 mm	L2 mm	D2 mm	FMGA13E	
					MD	€
FMGA1355E	5	80	38	5	50,14	
FMGA1366E	6	85	40	6	55,38	
FMGA1388E	8	90	38	8	71,18	
FMGA1388EX	8	110	43	8	93,39	
FMGA131010E	10	100	40	10	102,06	
FMGA131010EL	10	120	60	10	132,29	

HÉLICE B



B	D1 mm	L1 mm	L2 mm	D2 mm	FMGA13HI	
					MD	€
FMGA1333HI	3	50	8	3	29,64	
FMGA1344HI	4	64	12	4	29,65	
FMGA1355HI	5	64	16	5	32,10	
FMGA1366HI	6	64	20	6	48,47	
FMGA1388HI	8	76	38	8	64,13	
FMGA131010HI	10	76	35	10	78,38	

HÉLICE C



C	D1 mm	L1 mm	L2 mm	D2 mm	FMGA13CO	
					MD	€
FMGA1366CO	6	64	25	6	117,48	
FMGA1388CO	8	64	25	8	162,46	
FMGA131010CO	10	76	35	10	190,94	
FMGA131212CO	12	76	35	12	253,31	

CANAL RECTO



R	D1 mm	L1 mm	L2 mm	D2 mm	FMGA13R	
					MD	€
FMGA1346R	4	64	16	6	43,45	
FMGA1356R	5	64	20	6	43,45	
FMGA1366R	6	64	25	6	50,58	
FMGA1388R	8	64	25	8	74,81	
FMGA131010R	10	88	35	10	97,91	
FMGA131212R	12	88	35	12	141,32	

TIPOS DE HÉLICES

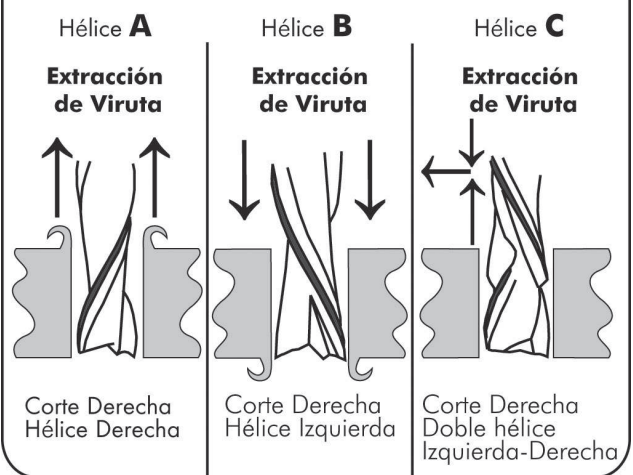

VELOCIDADES DE CORTE

D1 mm	HSSCo		MD	
	Aluminio (R.P.M.)	P.V.C. (R.P.M.)	Aluminio (R.P.M.)	P.V.C. (R.P.M.)
3,00	12000	12000	19000	19000
4,00	11000	11000	18000	18000
5,00	10000	10000	18000	18000
6,00	10000	10000	17000	17000
7,00	9000	9000	17000	17000
8,00	9000	9000	16000	16000
9,00	9000	9000	16000	16000
10,00	9000	9000	16000	16000

NOTA: Para la serie larga conviene reducir las RPM en un 15%

FRESAS PARA RANURAR

RANURAR
EN "T"DIN
851A

Ref. FF17

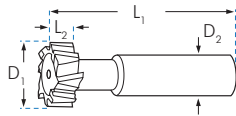
TOL D1
d11TOL D2
h6

FF17

D1 x L2 mm	D2 mm	Z	L1 mm	HSSCo €	TiAIN €
11,0x4,0	10	4	53,5	84,33	103,61
12,5x6,0	10	6	57,0	87,66	109,59
16,0x8,0	10	6	62,0	96,39	122,29
18,0x8,0	12	8	70,0	101,54	130,76
21,0x9,0	12	8	74,0	111,83	157,07
25,0x11,0	16	8	82,0	126,21	171,05
32,0x14,0	16	10	90,0	159,20	221,82
40,0x18,0	25	10	108,0	220,83	309,24
50,0x22,0	32	10	124,0	243,41	348,23
60,0x28,0	32	10	139,0	254,45	364,06
72,0x35,0	32	10	153,0	265,51	379,88

RANURAR
EN "T"DIN
851B

Ref. FF17C

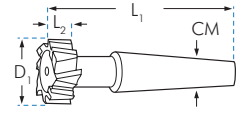
TOL D2
h12

FF17C

D1 x L2 mm	CM	ROSCA	L1 mm	HSSCo €	TiAIN €
11,0x4,0			53,5		
12,5x6,0			57,0		
16,0x8,0			62,0		
18,0x8,0	1	M6	70,0	110,63	137,17
21,0x9,0	2	M10	74,0	121,46	150,61
25,0x11,0	2	M10	82,0	126,63	157,03
32,0x14,0	2	M10	90,0	168,88	209,41
40,0x18,0	3	M12	108,0	213,51	264,76
50,0x22,0	4	M16	124,0	282,00	349,67
60,0x28,0	4	M16	139,0	373,12	462,66
72,0x35,0	5	M20	153,0	506,45	627,98

FRESA DE 1/4 DE CÍRCULO PARA
REMATADO DE ARISTAS

4 Z

HSSCo
8%DIN
6518N

WELDON

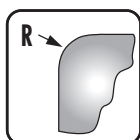
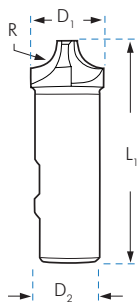

FF1/4R

	TOL H11 R	±15 D1 mm	TOL h6 D2 mm	L1 mm	€
FF1/4R1	1,0	8	10	60	56,00
FF1/4R1.50	1,5	9	10	60	54,17
FF1/4R2	2,0	10	10	60	45,57
FF1/4R2.50	2,5	11	10	60	52,43
FF1/4R3	3,0	12	12	60	52,24
FF1/4R3.50	3,5	13	12	60	68,04
FF1/4R4	4,0	14	12	60	58,00
FF1/4R4.50	4,5	15	12	60	77,54
FF1/4R5	5,0	16	12	60	65,00
FF1/4R5.50	5,5	19	16	67	77,54
FF1/4R6	6,0	20	16	67	65,12
FF1/4R6.50	6,5	21	16	71	98,69
FF1/4R7	7,0	22	16	71	88,99
FF1/4R7.50	7,5	23	16	71	107,43
FF1/4R8	8,0	24	16	71	88,99
FF1/4R8.50	8,5	25	25	85	131,59
FF1/4R9	9,0	26	25	85	115,98
FF1/4R9.50	9,5	27	25	85	138,30
FF1/4R10	10,0	28	25	85	115,98
FF1/4R10.50	10,5	31	25	90	161,13
FF1/4R11	11,0	32	25	90	154,85
FF1/4R12	12,0	34	25	90	127,58
FF1/4R12.50	12,5	41	25	100	165,68
FF1/4R13	13,0	42	25	100	205,37
FF1/4R14	14,0	44	25	100	213,10
FF1/4R15	15,0	46	25	100	265,30
FF1/4R16	16,0	48	25	100	243,84
FF1/4R18	18,0	52	32	112	314,52
FF1/4R20	20,0	56	32	112	353,35

FRESA PARA RANURAR
"WOODRUFF"TIPO
WOODRUFFDIN
850BTOL D1
h12TOL D2
h6

Ref. FF16

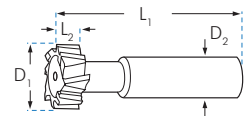

FF16

D1 x L2 mm	D2 mm	Z	L1 mm	HSSCo €	TiAIN €
4,5x1,0	6	6	50	45,85	54,23
7,5x1,5	6	6	50	47,74	57,39
7,5x2,0	6	6	50	47,74	57,39
10,5x2,0	6	6	50	51,37	61,93
10,5x2,5	6	6	50	51,37	61,93
10,5x3,0	6	6	50	51,37	61,93
13,5x3,0	10	6	56	52,19	65,18
13,5x4,0	10	6	56	52,19	65,18
16,5x3,0	10	6	56	52,66	69,80
16,5x4,0	10	6	56	52,66	69,80
16,5x5,0	10	6	56	52,66	67,53
19,5x4,0	10	8	63	59,94	79,18
19,5x5,0	10	8	63	59,94	75,87
19,5x6,0	10	8	63	59,94	75,87
22,5x5,0	10	8	63	65,67	87,96
22,5x6,0	10	8	63	65,67	88,39
22,5x8,0	10	8	63	65,67	88,39
25,5x6,0	10	10	63	76,89	109,46
28,5x6,0	10	10	63	78,21	110,78
28,5x8,0	10	10	63	78,21	110,78
28,5x10,0	12	10	71	78,21	110,78
32,5x7,0	12	10	71	97,00	132,57
32,5x8,0	12	10	71	97,00	132,57
32,5x10,0	12	10	71	97,00	132,57
45,5x10,0	12	12	71	153,46	218,16

FRESAS CÓNICAS ANGULARES, CON MANGO CILÍNDRICO HSSCo



Ref. FF98
Ref. FF99

HSSCo

DIN 1833A

TOL D1 js16

TOL D2 h6



Ref. FF97
Ref. FF95

HSSCo

DIN 1833B

TOL D1 js16

TOL D2 h6

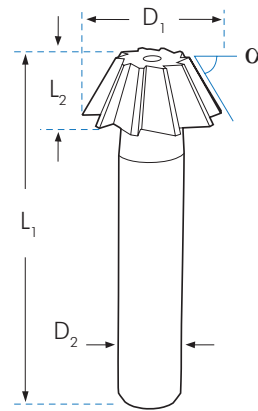
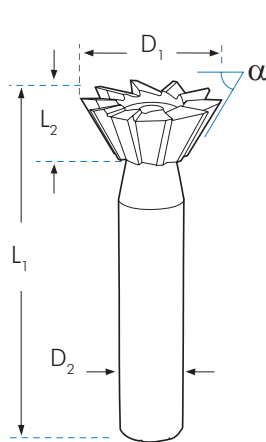

FF98							
45°	D1 mm	α	D2 mm	L1 mm	L2 mm	Z	€
FF981600	16	45°	12	60	4,0	8	85,28
FF982000	20	45°	12	63	5,0	10	90,42
FF982500	25	45°	12	67	6,3	12	110,57
FF983200	32	45°	16	71	8,0	14	123,38

FF97							
45°	D1 mm	α	D2 mm	L1 mm	L2 mm	Z	€
FF971600	16	45°	12	60	4,0	8	68,66
FF972000	20	45°	12	63	5,0	10	77,21
FF972500	25	45°	12	67	6,3	12	86,81
FF973200	32	45°	16	71	8,0	12	98,73

FF99							
60°	D1 mm	α	D2 mm	L1 mm	L2 mm	Z	€
FF991600	16	60°	12	60	6,3	8	85,25
FF992000	20	60°	12	63	8,0	10	90,39
FF992500	25	60°	12	67	10,0	12	110,54
FF993200	32	60°	16	71	12,5	14	123,34

FF95							
60°	D1 mm	α	D2 mm	L1 mm	L2 mm	Z	€
FF951600	16	60°	12	60	6,3	8	67,36
FF952000	20	60°	12	63	8,0	10	75,76
FF952500	25	60°	12	67	10,0	12	85,20
FF953200	32	60°	16	71	12,5	12	96,88

MEDIDAS ESPECIALES							FF99
FF991600-50	16	50°	12	60	5,0	8	95,74
FF992000-50	20	50°	12	63	6,3	10	102,05
FF992500-50	25	50°	12	67	8,0	12	126,09
FF991600-55	16	55°	12	60	5,6	8	95,74
FF992000-55	20	55°	12	63	7,1	10	102,05
FF992500-55	25	55°	12	67	9,0	12	126,09
FF991600-75	16	75°	12	60	8,0	8	95,74
FF992500-75	25	75°	12	67	10,0	12	126,09
FF991600-80	16	80°	12	60	8,0	8	95,74
FF992500-80	25	80°	12	67	10,0	12	126,09
FF991600-85	16	85°	12	60	8,0	8	95,74
FF992500-85	25	85°	12	67	10,0	12	126,09

MEDIDAS ESPECIALES							FF95
FF951600-50	16	50°	12	60	5,0	8	79,93
FF952000-50	20	50°	12	63	6,3	10	102,04
FF952500-50	25	50°	12	67	8,0	12	127,30
FF951600-55	16	55°	12	60	5,6	8	79,93
FF952000-55	20	55°	12	63	7,1	10	102,04
FF952500-55	25	55°	12	67	9,0	12	127,30
FF951600-75	16	75°	12	60	8,0	8	79,93
FF952500-75	25	75°	12	67	10,0	12	127,30

FRESAS FRONTALES CON MANGO CÓNICO SERIE CORTA
4-8 Z

INOX
Al
2 Z

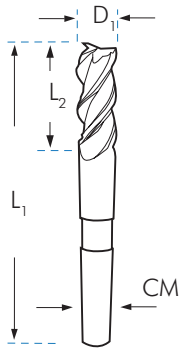
SERIE CORTA

DIN 845B			MATERIAL			FF09						FF35			FF39			FF10			FF46			FF48			DIN 326			FF55		
			ACABADO			CALIDAD			DESBASTE			HSSCo 8%			HSSCo 8%			HSSCo 8%			HSSCo 8%			HSSCo 8%			HSSCo 8%			HSSCo 8%		
BRILLANTE			★★			TOL k10			BRILLANTE			TiN			TiAlN			BRILLANTE			TiN			TiAlN			BRILLANTE					
★★			★★★			TOL k10			★★			★★★			★★★			NR			NR			NR			TOL e8					
TOL k10			TOL k10			TOL k10			TOL k12			TOL k12			TOL k12			TOL k12			TOL k12			TOL e8								
D1	L1	L2	Z	CM	ROSCA	€	€	€	€	€	€	€	€	€	€	L1	L2	Z	€													
mm	mm	mm														mm	mm															
10,00	92	22	4	1	M6	46,40	64,43	66,35	68,82	85,98	88,48	83	13	2	58,34																	
12,00	111	26	4	2	M6	61,34	78,69	82,48	70,14	87,79	91,19	86	16	2	60,56																	
14,00	111	26	4	2	M10	67,97	86,17	91,15	79,68	98,09	102,87	101	16	2	62,84																	
15,00	111	26	4	2	M10	72,92	94,31	98,86	99,56	119,94	125,77																					
16,00	117	32	4	2	M10	67,66	89,44	93,74	82,19	103,97	107,99	104	19	2	68,66																	
18,00	117	32	4	2	M10	71,87	93,35	97,84	90,21	111,34	116,76	104	19	2	71,97																	
20,00	123	38	4	2	M10	80,17	105,13	110,19	99,20	123,82	129,84	107	22	2	75,53																	
22,00	123	38	5	2	M10	90,67	114,37	120,98	109,22	133,05	139,50	107	22	2	88,96																	
24,00	147	45	6	3	M12	137,12	157,33	167,99	152,28	174,63	183,10	128	26	2	115,09																	
25,00	154	45	5	3	M12	123,77	152,23	161,08	152,32	180,86	189,65	128	26	2	120,97																	
26,00	147	45	6	3	M12	124,98	158,07	161,08	167,33	194,66	204,15	128	26	2	127,00																	
28,00	154	50	5	3	M12	124,98	158,07	161,08	167,38	194,66	204,15	128	26	2	140,22																	
30,00	154	50	6	3	M12	138,11	181,62	185,06	196,53	232,47	243,79	128	26	2	154,36																	
32,00	178	53	6	4	M16	181,42	233,05	237,49	233,04	287,56	301,54	157	32	2	169,95																	
36,00	178	53	6	4	M16	206,64	258,11	265,63	256,90	312,14	327,32	157	32	2	216,78																	
40,00	188	63	6	4	M16	248,96	309,77	318,77	358,89	422,46	442,98	163	38	2	249,84																	
45,00	188	63	6	4	M16	320,63	392,56	403,86	407,91	467,11	489,83	163	38	2	360,83																	
50,00	233	75	6	5	M20	386,26	453,63	466,71	432,60	509,33	534,07	203	45	2	453,31																	
56,00	233	75	8	5	M20	532,85	590,11	607,11	616,00	658,32	690,32																					
63,00	241	90	8	5	M20	669,00	716,87	737,51	773,70	803,23	842,25																					

FRESAS FRONTALES CON MANGO CÓNICO SERIE LARGA DIN 845B/L

4-8 Z



SERIE LARGA

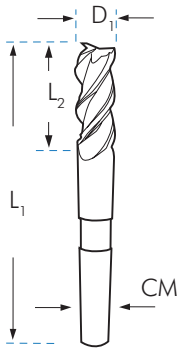

DIN 845B/L						MATERIAL	FF11	FF61	FF71	FF12	FF33	FF43
						ACABADO	HSSCo 8%	HSSCo 8%	HSSCo 8%	HSSCo 8%	HSSCo 8%	HSSCo 8%
						CALIDAD	BRILLANTE	TiN	TiAlN	BRILLANTE	TiN	TiAlN
						DESBASTE	★★	★★★	★★★	★★	★★★	★★★
						TOL k10	TOL k10	TOL k10	TOL k12	TOL k12	TOL k12	TOL k12
D1 mm	L1 mm	L2 mm	Z	CM	ROSCA	€	€	€	€	€	€	€
10,00	115	45	4	1	M6	84,28	102,72	106,20	123,00	140,55	145,33	
12,00	138	53	4	2	M6	79,46	102,72	109,21	125,31	142,40	148,62	
14,00	138	53	4	2	M10	83,62	111,58	116,45	157,88	174,76	182,40	
15,00	138	53	4	2	M10	91,80	116,98	122,06	181,56	200,80	209,59	
16,00	148	63	4	2	M10	90,87	114,05	119,02	131,32	153,33	160,03	
18,00	148	63	4	2	M10	103,24	125,20	130,63	136,31	158,08	164,98	
20,00	160	75	4	2	M10	114,53	140,05	146,14	156,37	181,38	189,28	
22,00	160	75	5	2	M10	129,62	154,10	161,54	162,40	187,05	195,21	
24,00	192	90	5	3	M12	176,32	199,55	210,20	220,51	244,02	256,31	
25,00	184	80	5	3	M12	175,11	205,92	216,37	230,55	259,92	271,25	
26,00	192	90	5	3	M12	193,95	222,33	233,64	239,58	268,44	280,16	
28,00	192	90	5	3	M12	196,53	235,26	247,80	237,84	268,44	280,16	
30,00	192	90	5	3	M12	226,55	264,17	277,58	283,65	321,53	335,58	
32,00	229	100	6	4	M16	267,09	312,80	328,68	337,81	383,86	400,63	
36,00	231	106	6	4	M16	305,83	350,75	368,55	386,93	431,89	450,73	
40,00	250	125	6	4	M16	339,83	394,66	414,72	475,47	528,50	551,60	
45,00	250	125	6	4	M16	458,02	524,76	552,75	606,46	667,85	697,03	
50,00	268	110	6	5	M20	558,98	614,81	647,62	756,81	809,91	845,27	
56,00	308	150	8	5	M20	588,24	641,90	677,27	881,92	928,07	977,69	
63,00	338	180	8	5	M20	778,08	818,67	862,20	1.110,27	1.143,82	1.204,94	

Fresas

Rosa

JUEGOS DE FRESAS CON CORTE AL CENTRO EN ESTUCHES DE PLÁSTICO

2Z

DIN
327

4Z

DIN
844

REFERENCIA	PTF20	PTF60
Nº FRESAS	8	8
TIPO	Ref. FF02	Ref. FF60
CALIDAD	HSSCo 8%	TiAlN
CONTENIDO	6 8 10 12	6 8 10 12
Ø mm	2 2 2 2	2 2 2 2
P.V.P. €	125,48	198,94

REFERENCIA	PTF24	PTF64
Nº FRESAS	8	8
TIPO	Ref. FF18	Ref. FF20
CALIDAD	HSSCo 8%	TiAlN
CONTENIDO	6 8 10 12	6 8 10 12
Ø mm	2 2 2 2	2 2 2 2
P.V.P. €	138,92	210,77

2Z

DIN
327

4Z

DIN
844

REFERENCIA	PTF21	PTF61
Nº FRESAS	6	6
TIPO	Ref. FF02	Ref. FF60
CALIDAD	HSSCo 8%	TiAlN
CONTENIDO	6-8-10-12-16-20	6-8-10-12-16-20
Ø mm		
P.V.P. €	135,80	206,58

REFERENCIA	PTF25	PTF65
Nº FRESAS	6	6
TIPO	Ref. FF18	Ref. FF20
CALIDAD	HSSCo 8%	TiAlN
CONTENIDO	6-8-10-12-16-20	6-8-10-12-16-20
Ø mm		
P.V.P. €	151,64	218,70

2Z

DIN
327

4Z

DIN
844

REFERENCIA	PTF22	PTF62
Nº FRESAS	6	6
TIPO	Ref. FF02	Ref. FF60
CALIDAD	HSSCo 8%	TiAlN
CONTENIDO	4-5-6-8-10-12	4-5-6-8-10-12
Ø mm		
P.V.P. €	86,05	138,38

REFERENCIA	PTF26	PTF66
Nº FRESAS	6	6
TIPO	Ref. FF18	Ref. FF20
CALIDAD	HSSCo 8%	TiAlN
CONTENIDO	4-5-6-8-10-12	4-5-6-8-10-12
Ø mm		
P.V.P. €	95,29	146,92

JUEGOS DE FRESAS CON CORTE AL CENTRO EN ESTUCHES METÁLICOS

2Z



DIN
327

Ref. FF020787

Ref. FT020787

Ref. FF600787



REFERENCIA	FF010787	FF020787	FT020787	FF600787
Nº FRESAS	6	6	6	6
TIPO	Ref. FF01	Ref. FF02	Ref. FT02	Ref. FF60
CALIDAD	HSS	HSSCo 8%	TiAlSiN	TiAlN
CONTENIDO Ø mm	4 - 5 - 6 - 8 - 10 - 12	4 - 5 - 6 - 8 - 10 - 12	4 - 5 - 6 - 8 - 10 - 12	4 - 5 - 6 - 8 - 10 - 12
P.V.P. €	79,65	105,33	120,55	157,66

REFERENCIA	FF010447	FF020447	FT020447	FF600447
Nº FRESAS	6	6	6	6
TIPO	Ref. FF01	Ref. FF02	Ref. FT02	Ref. FF60
CALIDAD	HSS	HSSCo 8%	TiAlSiN	TiAlN
CONTENIDO Ø mm	6 - 8 - 10 - 12 - 16 - 20	6 - 8 - 10 - 12 - 16 - 20	6 - 8 - 10 - 12 - 16 - 20	6 - 8 - 10 - 12 - 16 - 20
P.V.P. €	119,13	157,99	180,83	228,75

REFERENCIA	FF010801	FF020801	FT020801	FF600801
Nº FRESAS	14	14	14	14
TIPO	Ref. FF01	Ref. FF02	Ref. FT02	Ref. FF60
CALIDAD	HSS	HSSCo 8%	TiAlSiN	TiAlN
CONTENIDO Ø mm	3 - 4 - 5 - 6 - 7 - 8 - 9 - 10 12 - 14 - 15 - 16 - 18 - 20	3 - 4 - 5 - 6 - 7 - 8 - 9 - 10 12 - 14 - 15 - 16 - 18 - 20	3 - 4 - 5 - 6 - 7 - 8 - 9 - 10 12 - 14 - 15 - 16 - 18 - 20	3 - 4 - 5 - 6 - 7 - 8 - 9 - 10 12 - 14 - 15 - 16 - 18 - 20
P.V.P. €	282,48	371,19	424,85	524,42

ESTUCHES METÁLICOS VACÍOS PARA FRESAS

2-4Z



DIN
327

REFERENCIA	EV0787	EV0847	EV0764
Nº FRESAS	6	6	14
CONTENIDO Ø mm	4 - 5 - 6 - 8 - 10 - 12	6 - 8 - 10 - 12 - 16 - 20	3 - 4 - 5 - 6 - 7 - 8 - 9 - 10 12 - 14 - 15 - 16 - 18 - 20
P.V.P. €	24,83	27,75	80,35



Fresas

Rosa

JUEGOS DE FRESAS EN ESTUCHES METÁLICOS

4 Z

DIN
844

REFERENCIA	FF030787	FF040787	FT040787	FF540787
Nº FRESAS	6	6	6	6
TIPO	Ref. FF03	Ref. FF04	Ref. FT04	Ref. FF54
CALIDAD	HSS	HSSCo 8%	TiAlSiN	TiAlN
CONTENIDO Ø mm	4 - 5 - 6 - 8 - 10 - 12	4 - 5 - 6 - 8 - 10 - 12	4 - 5 - 6 - 8 - 10 - 12	4 - 5 - 6 - 8 - 10 - 12
P.V.P. €	78,34	103,31	118,80	157,65

REFERENCIA	FF030847	FF040847	FT040847	FF540847
Nº FRESAS	6	6	6	6
TIPO	Ref. FF03	Ref. FF04	Ref. FT04	Ref. FF54
CALIDAD	HSS	HSSCo 8%	TiAlSiN	TiAlN
CONTENIDO Ø mm	6 - 8 - 10 - 12 - 16 - 20	6 - 8 - 10 - 12 - 16 - 20	6 - 8 - 10 - 12 - 16 - 20	6 - 8 - 10 - 12 - 16 - 20
P.V.P. €	117,04	157,04	180,60	226,22



REFERENCIA	FF030764	FF040764	FT040764	FF540764
Nº FRESAS	14	14	14	14
TIPO	Ref. FF03	Ref. FF04	Ref. FT04	Ref. FF54
CALIDAD	HSS	HSSCo 8%	TiAlSiN	TiAlN
CONTENIDO Ø mm	3 - 4 - 5 - 6 - 7 - 8 - 9 - 10 12 - 14 - 15 - 16 - 18 - 20	3 - 4 - 5 - 6 - 7 - 8 - 9 - 10 12 - 14 - 15 - 16 - 18 - 20	3 - 4 - 5 - 6 - 7 - 8 - 9 - 10 12 - 14 - 15 - 16 - 18 - 20	3 - 4 - 5 - 6 - 7 - 8 - 9 - 10 12 - 14 - 15 - 16 - 18 - 20
P.V.P. €	273,92	362,74	417,15	521,48

4 Z

DIN
844

NR

REFERENCIA	FF250847	FT250847	FF270847
Nº FRESAS	6	6	6
TIPO	Ref. FF25	Ref. FT25	Ref. FF27
CALIDAD	HSSCo 8%	TiAlSiN	TiAlN
CONTENIDO Ø mm	6 - 8 - 10 - 12 - 16 - 20	6 - 8 - 10 - 12 - 16 - 20	6 - 8 - 10 - 12 - 16 - 20
P.V.P. €	292,31	334,57	351,60

JUEGOS DE FRESAS EN ESTUCHES METÁLICOS

4 Z  **DIN 844**

REFERENCIA	FF180787	FT180787	FF200787
Nº FRESAS	6	6	6
TIPO	Ref. FF18	Ref. FT18	Ref. FF20
CALIDAD	HSSCo 8%	TiAlSiN	TiAlN
CONTENIDO Ø mm	4 - 5 - 6 - 8 - 10 - 12	4 - 5 - 6 - 8 - 10 - 12	4 - 5 - 6 - 8 - 10 - 12
P.V.P. €	109,99	125,88	166,18



Ref. FF180787

REFERENCIA	FF180847	FT180847	FF200847
Nº FRESAS	6	6	6
TIPO	Ref. FF18	Ref. FT18	Ref. FF20
CALIDAD	HSSCo 8%	TiAlSiN	TiAlN
CONTENIDO Ø mm	6 - 8 - 10 - 12 - 16 - 20	6 - 8 - 10 - 12 - 16 - 20	6 - 8 - 10 - 12 - 16 - 20
P.V.P. €	171,95	196,81	238,58



Ref. FF180847

REFERENCIA	FF180764	FT180764	FF200764
Nº FRESAS	14	14	14
TIPO	Ref. FF18	Ref. FT18	Ref. FF20
CALIDAD	HSSCo 8%	TiAlSiN	TiAlN
CONTENIDO Ø mm	3 - 4 - 5 - 6 - 7 - 8 - 9 - 10 - 12 - 14 - 15 - 16 - 18 - 20	3 - 4 - 5 - 6 - 7 - 8 - 9 - 10 - 12 - 14 - 15 - 16 - 18 - 20	3 - 4 - 5 - 6 - 7 - 8 - 9 - 10 - 12 - 14 - 15 - 16 - 18 - 20
P.V.P. €	393,19	450,03	543,28



Ref. FF180764







EXPOSITOR DE METACRILATO

Ref. MF-01

MF-01

Contenido: 163 Fresas



Ref. FF13	1 Z	HSSCo	Al	SERIE CORTA	Ø / Cant.	5 x 8 / 5 Mango	6 x 8 / 5 Mango
Ref. FF14	1 Z	HSSCo	Al	SERIE LARGA	Ø / Cant.	5 x 8 / 5 Mango	6 x 8 / 5 Mango
Ref. FF02	2 Z		HSSCo	DIN 327N		Ø / Cant.	2/5 3/5 4/5 5/5 6/5 7/5 8/5 9/5 10/5 12/5 14/5 16/3
Ref. FF18	4 Z		HSSCo	DIN 844N		Ø / Cant.	2/5 3/5 4/5 5/5 6/5 7/5 8/5 9/5 10/5 12/5 14/5 16/3
Ref. FF25	4 Z		HSSCo	DIN 844N	 	Ø / Cant.	6/3 7/3 8/3 9/3 10/3 11/3 12/3 14/3 16/3

Dimensiones: ancho 245 x fondo 210 x alto 350 mm
NOTA: Composiciones especiales bajo demanda

P.V.P. 3.253,13 €

PARÁMETROS DE CORTE ORIENTATIVOS FRESAS HSSCo 8%

		DIÁMETRO Ø (mm)														
		2	4	6	8	10	12	18	22	26	30	32	36	40		
ACERO BLANDO 70 kg/mm ²	V/C 39	RPM	6207	3104	2069	1552	1241	1035	690	564	477	414	388	345	310	
	AVANCE (mm/min)	Nº cortes	2	50	56	74	84	82	81	80	81	76	68	68	62	60
			3	74	84	112	126	123	121	120	122	115	102	102	93	89
			4	99	112	149	168	164	161	160	163	153	136	137	124	119
ACERO TRATADO 120 kg/mm ²	V/C 20	RPM	3183	1592	1061	796	637	531	354	289	245	212	199	177	159	
	AVANCE (mm/min)	Nº cortes	2	25	29	38	43	42	41	41	42	39	35	35	32	31
			3	38	43	57	64	63	62	62	63	59	52	53	48	46
			4	51	57	76	86	84	83	82	83	78	70	70	64	61
INOXIDABLE	V/C 15	RPM	2387	1194	796	597	477	398	265	217	184	159	149	133	119	
	AVANCE (mm/min)	Nº cortes	2	19	21	29	32	32	31	31	31	29	26	26	24	23
			3	29	32	43	48	47	47	46	47	44	39	39	36	34
			4	38	43	57	64	63	62	62	63	59	52	53	48	46
ALUMINIO	V/C 230	RPM	36606	18303	12202	9151	7321	6101	4067	3328	2816	2440	2288	2034	1830	
	AVANCE (mm/min)	Nº cortes	2	293	329	439	494	483	476	472	479	451	400	403	366	351
			3	439	494	659	741	725	714	708	719	676	600	604	549	527
			4	586	659	879	988	966	952	944	958	901	800	805	732	703
TITANIO	V/C 12	RPM	1910	955	637	477	382	318	212	174	147	127	119	106	95	
	AVANCE (mm/min)	Nº cortes	2	15	17	23	26	25	25	25	25	24	21	21	19	18
			3	23	26	34	39	38	37	37	38	35	31	32	29	28
			4	31	34	46	52	50	50	49	50	47	42	42	38	37

* Para fresas recubiertas y/o ASP 60, multiplicar los parámetros de la tabla por el factor 1,3

* V/C: Velocidad de corte (m/min)

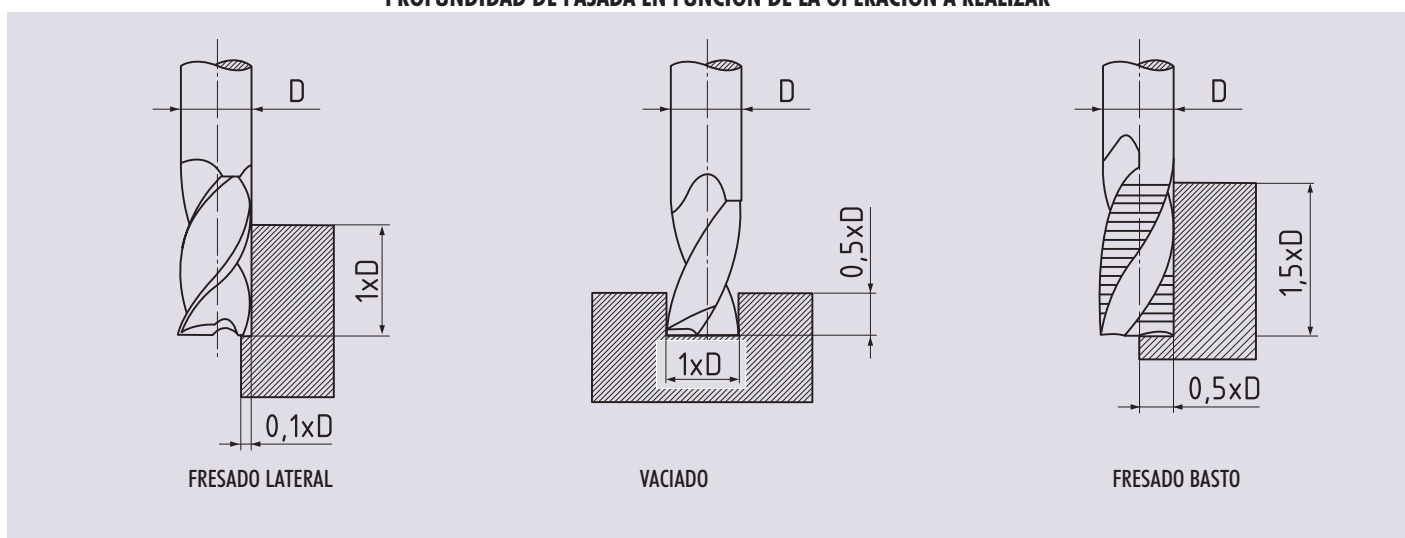
PROFUNDIDAD DE PASADA EN FUNCIÓN DE LA OPERACIÓN A REALIZAR

FRESAS METAL DURO



FRESAS DE METAL DURO INTEGRAL PARA APLICACIONES GENERALES SERIE CORTA, LARGA Y EXTRALARGA

Fresas

Rosa



SERIE CORTA

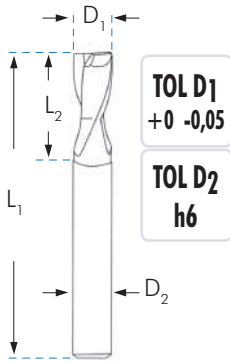

D1 mm	L1 mm	L2 mm	D2 mm	FMD2		FMD63		FMD48	
				MD	MD	MD	MD	MD	MD
				BRILLANTE	TiAIN	BRILLANTE	TiAIN	BRILLANTE	TiAIN
				★★	★★★	★★	★★★	★★	★★★
2Z		2Z		3Z		3Z		4Z	
€	€	€	€	€	€	€	€	€	€
1,00	38	3	3	15,34	20,34	15,34	20,34	15,34	20,34
1,50	38	4	3	15,34	20,34	15,34	20,34	15,34	20,34
2,00	38	6	3	15,34	20,34	15,34	20,34	15,34	20,34
2,50	38	8	3	15,34	20,34	15,34	20,34	15,34	20,34
3,00	38	8	3	14,72	19,72	14,72	19,72	14,72	19,72
3,50	50	11	4	17,20	22,20	17,20	22,20	17,20	22,20
4,00	50	11	4	14,63	19,63	14,63	19,63	14,63	19,63
4,50	50	13	5	18,84	23,84	18,84	23,84	18,84	23,84
5,00	50	13	5	16,61	21,61	16,61	21,61	16,61	21,61
6,00	50	16	6	18,17	23,17	18,17	23,17	18,17	23,17
7,00	60	16	8	29,73	35,73	29,73	35,73	29,73	35,73
8,00	60	19	8	27,00	33,00	27,00	33,00	27,00	33,00
9,00	72	19	10	42,79	49,79	42,79	49,79	42,79	49,79
10,00	72	22	10	40,57	47,57	40,57	47,57	40,57	47,57
11,00	75	26	12	67,75	75,75	67,75	75,75	67,75	75,75
12,00	75	26	12	51,73	59,73	51,73	59,73	51,73	59,73
14,00	84	30	14	79,48	89,48	79,48	89,48	79,48	89,48
16,00	92	32	16	102,69	113,69	102,69	113,69	102,69	113,69
18,00	100	38	18	150,46	165,46	150,46	165,46	150,46	165,46
20,00	100	38	20	171,14	190,14	171,14	190,14	171,14	190,14
25,00	100	38	25	296,98	325,98			296,98	325,98

SERIE LARGA

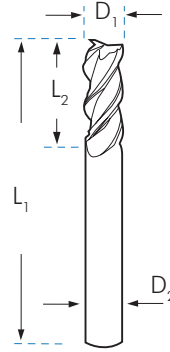

D1 mm	L1 mm	L2 mm	D2 mm	FMD54		FMD58	
				MD	MD	MD	MD
				BRILLANTE	TiAIN	BRILLANTE	TiAIN
				★★	★★★	★★	★★★
2Z		2Z		4Z		4Z	
€	€	€	€	€	€	€	€
3,00	60	15	3	16,29	22,29	16,29	22,29
4,00	80	20	4	17,17	23,17	17,17	23,17
5,00	80	25	5	21,37	27,37	21,37	27,37
6,00	90	35	6	30,14	36,14	30,14	36,14
8,00	90	35	8	34,32	42,32	34,32	42,32
10,00	100	45	10	48,50	56,50	48,50	56,50
12,00	100	50	12	66,21	76,21	66,21	76,21
14,00	150	65	14	108,94	121,94	108,94	121,94
16,00	150	65	16	119,35	132,35	119,35	132,35
18,00	150	65	18	172,36	190,36		
20,00	150	70	20	211,71	231,71		

SERIE EXTRA LARGA

Ø mm	L1 mm	L2 mm	D2 mm	FMD53		FMD56	
				MD	MD	MD	MD
				BRILLANTE	TiAIN	BRILLANTE	TiAIN
				★★	★★★	★★	★★★
2Z		2Z		4Z		4Z	
€	€	€	€	€	€	€	€
3,00	75	25	3	35,04	45,04	36,25	46,25
4,00	100	25	4	38,06	48,06	39,25	49,25
5,00	100	25	5	43,02	53,02	45,21	55,21
6,00	150	75	6	71,80	87,80	78,98	94,98
8,00	150	75	8	98,87	117,87	108,75	127,75
10,00	150	75	10	125,23	150,23	137,76	162,76
12,00	150	75	12	183,24	215,24	201,56	233,56
14,00	150	75	14	253,31	292,31	278,64	317,64
16,00	200	75	16	344,16	389,16	378,57	423,57
18,00	200	75	18	366,71	415,71	403,38	452,38
20,00	200	75	20	537,00	597,00	537,00	597,00

FRESAS DE METAL DURO INTEGRAL PARA APLICACIONES GENERALES SERIE CORTA, LARGA Y EXTRALARGA



SERIE CORTA

SERIE LARGA

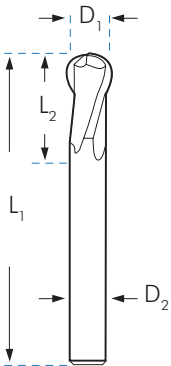

TOL D1
+0 -0,05
TOL D2
h6

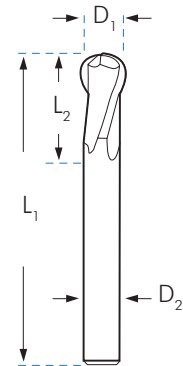

MATERIAL ACABADO CALIDAD				FMD92	FMD92TL	FMD51	FMD51TL
MATERIAL				MD	MD	MD	MD
ACABADO				BRILLANTE	TiAlN	BRILLANTE	TiAlN
CALIDAD				★★	★★★	★★	★★★
				2Z	2Z	4Z	4Z
D1 mm	L1 mm	L2 mm	D2 mm	€	€	€	€
1,00	38	2	3	18,41	23,41		
1,50	38	3	3	18,41	23,41		
2,00	38	4	3	18,41	23,41		
2,50	38	5	3	18,41	23,41		
3,00	38	6	3	18,41	23,41	20,25	25,75
4,00	50	8	4	20,97	25,97	23,06	28,56
5,00	50	10	5	22,19	27,19	24,41	29,91
6,00	50	12	6	26,11	31,11	28,72	34,22
8,00	60	15	8	32,24	38,24	40,30	47,80
10,00	75	20	10	48,43	55,43	60,54	69,29
12,00	75	20	12	60,18	68,18	75,22	85,22
14,00	90	25	14	89,09	99,09	111,36	123,86
16,00	100	25	16	112,71	123,71	140,89	154,64
18,00	100	30	18	167,58	182,58	209,47	228,22
20,00	100	30	20	173,72	192,72	217,15	240,90

MATERIAL ACABADO CALIDAD				FMD57	FMD57TL
MATERIAL				MD	MD
ACABADO				BRILLANTE	TiAlN
CALIDAD				★★	★★★
				2Z	2Z
D1 mm	L1 mm	L2 mm	D2 mm	€	€
3,00	60	4	3	27,75	33,75
4,00	80	5	4	32,21	38,21
5,00	80	6	5	38,09	44,09
6,00	80	8	6	44,52	50,52
8,00	100	12	8	58,77	66,77
10,00	100	15	10	72,60	81,60
12,00	100	15	12	125,82	135,82
14,00	150	20	14	157,77	170,77
16,00	150	20	16	199,26	212,26
18,00	150	25	18	309,51	324,51
20,00	150	25	20	411,30	431,30

CONDICIONES DE CORTE ORIENTATIVAS

	RPM	Ø2	Ø3	Ø4	Ø5	Ø6	Ø8	Ø10	Ø12	Ø14
	AVANCE (mm/min)	4000	2600	2000	1600	1300	1000	800	660	570
	RPM	50	55	55	55	55	55	55	55	55
	AVANCE (mm/min)	8000	5300	4000	3200	2600	2000	1600	1300	1100
	RPM	55	55	55	55	60	60	60	60	60
	AVANCE (mm/min)	16000	11000	8000	6400	5300	4000	3200	2600	2300
	RPM	290	290	290	290	290	290	290	290	290

* Para obtener parámetros de corte recomendados para fresas recubiertas de TiAlN, multiplicar valores del recuadro por el factor 1,3

SERIE EXTRA LARGA

MATERIAL ACABADO CALIDAD				FMD55	FMD55TL
MATERIAL				MD	MD
ACABADO				BRILLANTE	TiAlN
CALIDAD				★★	★★★
				2Z	2Z
D1 mm	L1 mm	L2 mm	D2 mm	€	€
3,00	75	6	3	33,25	43,25
4,00	100	6	4	38,36	48,36
5,00	100	6	5	46,36	56,36
6,00	100	15	6	58,25	68,25
8,00	150	25	8	78,25	93,25
10,00	150	25	10	110,25	125,25
12,00	150	25	12	175,36	203,36
14,00	200	50	14	215,36	247,36
16,00	200	50	16	289,36	324,36
18,00	200	75	18	425,00*	480,00*
20,00	200	75	20	550,00*	615,00*

*Hasta fin de existencias

FRESAS FRONTALES DE MD INTEGRAL DESBASTE FINO, MEDIO Y GRUESO

Fresas

Rosa



FMD1

FMD3

D1 mm	D2 mm	L1 mm	L2 mm	Z	€
TOL D1 +0 -0,05	TOL D2 h6				
6	6	63	19	3	78,25
8	8	63	19	3	83,99
10	10	63	22	3	107,37
12	12	75	25	4	135,61
16	16	88	32	4	232,03
20	20	100	38	4	271,59

D1 mm	D2 mm	L1 mm	L2 mm	Z	€
TOL D1 +0 -0,05	TOL D2 h6				
6	6	63	19	3	78,25
8	8	63	19	3	83,99
10	10	63	22	3	107,37
12	12	75	25	4	135,61
16	16	88	32	4	232,03
20	20	100	38	4	271,59

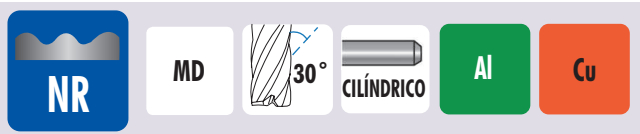

FMD6

D1 mm	D2 mm	L1 mm	L2 mm	Z	€
TOL D1 +0 -0,05	TOL D2 h6				
6	6	63	19	3	78,25
8	8	63	19	3	83,99
10	10	63	22	3	107,37
12	12	75	25	4	135,61
16	16	88	32	4	232,03
20	20	100	38	4	271,59

FRESAS DE METAL DURO INTEGRAL ESPECIALES PARA INOXIDABLE Y ALEACIONES DE NIQUEL

INOX Ni Ti 44 HRc **CILÍNDRICO** **2Z** **3Z** **4Z** **Muy recomendado para mecanizado de inoxidable, titanio y aleaciones de níquel.** **Micro Grano MD**

SERIE CORTA

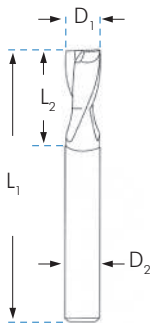

TOL D1
+0 -0,05
TOL D2
h6



				FMT2	FMT63	FMT48
MATERIAL				MD	MD	MD
ACABADO				TiAlSiN	TiAlSiN	TiAlSiN
CALIDAD				Premium Quality	Premium Quality	Premium Quality
				2Z	3Z	4Z
D1	L1	L2	D2	€	€	€
mm	mm	mm	mm			
1,00	38	3	3	38,51	38,51	38,51
1,50	38	4	3	37,60	37,60	37,60
2,00	38	6	3	29,93	29,93	29,93
2,50	38	8	3	29,24	29,24	29,24
3,00	38	8	3	25,19	25,19	25,19
3,50	50	11	4	30,91	30,91	30,91
4,00	50	11	4	28,72	28,72	28,72
4,50	50	13	5	36,74	36,74	36,74
5,00	50	13	5	36,29	36,29	36,29
6,00	50	16	6	40,92	40,92	40,92
7,00	60	16	8	57,07	57,07	57,07
8,00	60	19	8	48,43	48,43	48,43
9,00	72	19	10	69,44	69,44	69,44
10,00	72	22	10	77,20	77,20	77,20
11,00	75	26	12	102,70	102,70	102,70
12,00	75	26	12	95,49	95,49	95,49
14,00	84	30	14	141,94	141,94	141,94
16,00	92	32	16	183,88	183,88	183,88
18,00	100	38	18	255,51	255,51	255,51
20,00	100	38	20	291,31	291,31	291,31
25,00	100	38	25	478,16	478,16	478,16

				FMT81
MATERIAL				MD
ACABADO				TiAlSiN
CALIDAD				Premium Quality
				4Z
D1	L1	L2	D2	€
mm	mm	mm	mm	
1,00	38	3	3	
1,50	38	5	3	
2,00	38	6	3	
2,50	38	7	3	
3,00	38	12	3	
3,50	50	12	4	
4,00	50	14	4	
4,50	50	14	5	
5,00	50	16	5	39,92
6,00	63	19	6	45,01
7,00	63	19	8	
8,00	63	19	8	53,27
9,00	70	22	10	
10,00	70	22	10	84,91
11,00	75	25	11	
12,00	75	25	12	105,03
14,00	88	30	14	156,14
16,00	88	32	16	202,26
18,00	100	36	18	281,05
20,00	100	36	20	320,44
25,00	100	38	25	

				FMT92
MATERIAL				MD
ACABADO				TiAlSiN
CALIDAD				Premium Quality
				2Z
D1	L1	L2	D2	€
mm	mm	mm	mm	
1,00	38	2	3	
1,50	38	3	3	
2,00	38	4	3	
2,50	38	5	3	
3,00	38	6	3	33,25
4,00	50	8	4	36,89
5,00	50	10	5	45,59
6,00	50	12	6	52,17
8,00	60	15	8	64,13
10,00	75	20	10	92,97
12,00	75	20	12	114,33
14,00	90	25	14	166,17
16,00	100	25	16	207,47
18,00	100	30	18	306,20
20,00	100	30	20	323,21



FMT81: Fresa de 4 cortes, corte al centro, Hélice Variable con recubrimiento TiAlSiN. Su ángulo de Hélice Variable minimiza las vibraciones y junto con el recubrimiento TiAlSiN ofrece un espectacular rendimiento en el mecanizado.

CONDICIONES DE CORTE ORIENTATIVAS

		Ø 2	Ø 3	Ø 4	Ø 5	Ø 6	Ø 8	Ø 10	Ø 12	Ø 14	Ø 16	Ø 20	Ø 25
	RPM	5600	3640	2800	2240	1820	1400	1120	924	798	700	560	420
	AVANCE (mm/min)	70	77	77	77	77	77	77	77	77	91	91	70
INOX Ti	RPM	11200	7420	5600	4480	3640	2800	2240	1820	1540	1400	1120	840
	AVANCE (mm/min)	77	77	77	77	84	84	84	84	84	98	98	77
Ni	RPM	11200	7420	5600	4480	3640	2800	2240	1820	1540	1400	1120	840
	AVANCE (mm/min)	77	77	77	77	84	84	84	84	84	98	98	77

FRESA 2 LABIOS, SERIE CORTA, HÉLICE A 35°

INOX

Ref. FMG10

2 Z

MG
MD

WELDON

TiAlN

INOX



Ti

INC

SERIE CORTA

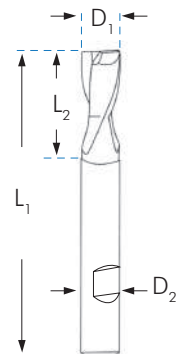
Micro Grano
MD

FMG10

	TOL -0,03	TOL h6			€
	D1 mm	D2 mm	L1 mm	L2 mm	
FMG100100	1,0	6	40	2,5	64,52
FMG100150	1,5	6	40	4,0	64,52
FMG100200	2,0	6	40	6,0	58,72
FMG100300	3,0	6	45	8,0	58,72
FMG100400	4,0	6	45	11,0	58,72
FMG100500	5,0	6	50	13,0	58,72
FMG100600	6,0	6	50	13,0	58,72
FMG100700	7,0	8	60	16,0	75,08
FMG100800	8,0	8	60	19,0	75,08
FMG100900	9,0	10	70	19,0	110,88
FMG101000	10,0	10	70	22,0	110,88
FMG101200	12,0	12	75	26,0	151,87
FMG101400	14,0	16	85	26,0	251,60
FMG101600	16,0	16	100	32,0	251,60
FMG101800	18,0	16	100	32,0	334,24
FMG102000	20,0	20	105	38,0	416,83
FMG102200	22,0	20	105	38,0	541,78
FMG102500	25,0	25	120	45,0	666,69

REVOLUCIONES Y AVANCES

<30 HRc		30-45 HRc		INOX	
R.P.M. rev./min	AVANCE mm/min	R.P.M. rev./min	AVANCE mm/min	R.P.M. rev./min	AVANCE mm/min
11.560	190	7.560	120	6.300	90
8.920	210	5.560	140	4.620	120
7.560	300	4.620	180	3.880	150
6.300	320	3.780	190	3.160	160
5.560	350	3.360	220	2.840	180
4.200	380	2.520	200	2.100	180
3.260	330	2.000	160	1.680	160
2.740	280	1.680	130	1.360	130
2.200	220	1.360	110	1.060	110
1.680	170	1.060	80	840	80
1.360	130	840	70	680	60

FRESA 3 LABIOS, SERIE CORTA, HÉLICE A 45°

INOX

Ref. FMD67

3 Z



MD



CILÍNDRICO

INOX

Ti

Ni

TiAlN

SERIE CORTA

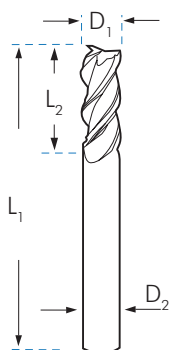
Micro Grano
MD

FMD67

	TOL e8	TOL h6			TiAlN
	D1 mm	D2 mm	L1 mm	L2 mm	€
FMD670300	3	3	32	17	26,28
FMD670400	4	4	40	12	29,97
FMD670500	5	5	50	14	37,86
FMD670600	6	6	63	20	42,70
FMD670800	8	8	63	22	50,53
FMD671000	10	10	70	25	80,56
FMD671200	12	12	75	25	99,65
FMD671400	14	14	83	30	148,11
FMD671600	16	16	88	30	191,88
FMD671800	18	18	100	38	239,16
FMD672000	20	20	100	38	303,98

FRESA 4 LABIOS, SERIE CORTA, HÉLICE A 35°

INOX Ref. FMG12

4 Z

MG MD

35°

WELDON

TiAlN

INOX

45 HRc

Ti

INC

SERIE CORTA

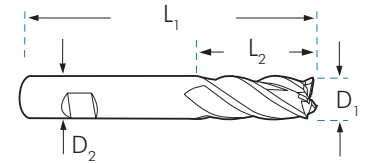

FMG12					
	TOL -0,03	TOL h6			
	D1 mm	D2 mm	L1 mm	L2 mm	€
FMG120200	2,0	6	40	6	58,72
FMG120250	2,5	6	40	8	58,72
FMG120300	3,0	6	45	8	58,72
FMG120400	4,0	6	45	11	58,72
FMG120500	5,0	6	50	13	58,72
FMG120600	6,0	6	50	13	58,72
FMG120700	7,0	8	60	16	75,08
FMG120800	8,0	8	60	19	75,08
FMG120900	9,0	10	70	19	110,88
FMG121000	10,0	10	70	22	110,88
FMG121200	12,0	12	75	26	151,87
FMG121400	14,0	16	85	26	251,60
FMG121600	16,0	16	100	32	251,60
FMG121800	18,0	16	100	32	334,24
FMG122000	20,0	20	105	38	416,83
FMG122200	22,0	20	105	38	541,78
FMG122500	25,0	25	120	40	666,69

REVOLUCIONES Y AVANCES					
<30 HRc		30-45 HRc		INOX	
R.P.M. rev./min	AVANCE mm/min	R.P.M. rev./min	AVANCE mm/min	R.P.M. rev./min	AVANCE mm/min
11.560	280	7.560	170	6.300	140
8.920	320	5.560	200	4.620	170
7.560	570	4.620	350	3.880	280
6.300	600	3.780	360	3.160	300
5.560	660	3.360	410	2.840	330
4.200	710	2.520	380	2.100	350
3.260	610	2.000	300	1.680	300
2.740	520	1.680	250	1.360	240
2.200	410	1.360	200	1.060	200
1.680	320	1.060	160	840	150
1.360	250	840	130	680	130

FRESA 6 Y 8 LABIOS, SERIE CORTA, HÉLICE A 45°

INOX Ref. FMG14

6-8 Z

MG MD

45°

WELDON

TiAlN

INOX

45 HRc

Ti

INC

SERIE CORTA

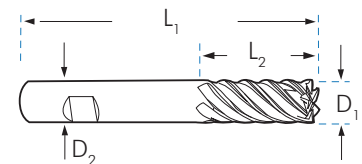

FMG14														
	TOL -0,03	TOL h6					<30 HRc	30-45 HRc	INOX	INC				
	D1 mm	D2 mm	L1 mm	L2 mm	Z	€	R.P.M. rev./min	AVANCE mm/min	R.P.M. rev./min	AVANCE mm/min	R.P.M. rev./min	AVANCE mm/min	R.P.M. rev./min	AVANCE mm/min
FMG140600	6,0	6	57	13	6	70,63	5.560	2.000	3.880	1.370	3.370	1.100	1.350	280
FMG140800	8,0	8	63	19	6	89,28	4.200	2.000	2.940	1.370	2.490	1.100	1.000	280
FMG141000	10,0	10	72	22	6	127,29	3.360	2.000	2.320	1.370	1.920	1.100	440	280
FMG141200	12,0	12	83	26	6	172,85	2.840	1.680	2.000	1.160	1.610	1.000	400	250
FMG141400	14,0	14	83	26	6	226,65	2.470	1.470	1.740	1.020	1.380	885	355	220
FMG141600	16,0	16	92	32	6	290,34	2.100	1.260	1.480	880	1.160	770	310	190
FMG141800	18,0	18	92	32	8	355,91	1890	1130	1.320	785	1.030	695	280	170
FMG142000	20,0	20	104	38	8	426,36	1680	1010	1.160	690	900	920	250	155
FMG142500	25,0	25	104	44	8	788,52	1500	900	1.100	600	850	540	220	135

FRESAS 4 LABIOS DE HÉLICE VARIABLE

INOX

Ref. FMG83

4 Z

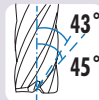
DIN
6527MG
MD

WELDON

TiAIN

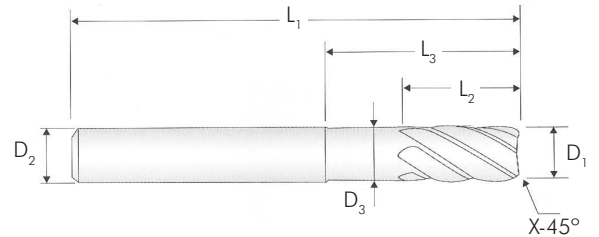
Micro Grano
MD

FMG83

REVOLUCIONES Y AVANCES

	TOL		FMG83					REVOLUCIONES Y AVANCES							
	-0,03	h6	D1	D2	L1	L2	L3	X-45°	€	INOX AISI 316L	INOX AISI 304	R.P.M. rev./min	AVANCE mm/min	R.P.M. rev./min	AVANCE mm/min
FMG830300			3,0	6	57	8	11	0,07	47,70			10.185	195	14.260	205
FMG830400			4,0	6	57	11	14	0,09	47,70			7.600	250	14.260	255
FMG830500			5,0	6	57	13	16	0,12	47,70			6.110	310	8.655	310
FMG830600			6,0	6	57	13	21	0,20	47,70			5.095	360	7.130	360
FMG830800			8,0	8	63	19	27	0,25	61,10			3.820	435	5.345	465
FMG831000			10,0	10	73	22	32	0,35	89,20			3.055	590	4.275	585
FMG831200			12,0	12	83	26	38	0,40	120,23			2.545	565	3.565	565
FMG831400			14,0	14	84	30	40	0,40	172,54			2.180	520	3.055	520
FMG831600			16,0	16	92	32	44	0,40	202,62			1.910	480	2.670	480
FMG832000			20,0	20	104	38	55	0,40	320,35			1.525	470	2.140	470

FRESA 3 A 4 LABIOS, SERIE CORTA, HÉLICE A 50°

INOX Ref. FMG13 **3-4 Z** **MG MD** **50°** **WELDON** **TiAlN** **INOX** **45 HRc** **Ti** **INC**

SERIE CORTA

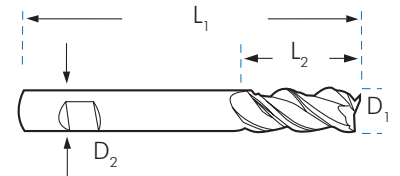

	FMG13						REVOLUCIONES Y AVANCES								
	TOL -0,03	TOL h6					€	<30 HRc		30-45 HRc		INOX		INC	
	D1 mm	D2 mm	L1 mm	L2 mm	Z	R.P.M. rev./min		AVANCE mm/min	R.P.M. rev./min	AVANCE mm/min	R.P.M. rev./min	AVANCE mm/min	R.P.M. rev./min	AVANCE mm/min	
FMG130600	6,0	6	50	13	3	76,18	5.560	310	3.360	200	2.840	160	1.280	40	
FMG130800	8,0	8	60	19	3	97,44	4.200	310	2.520	180	2.100	160	920	40	
FMG131000	10,0	10	70	22	3	143,96	3.260	310	2.000	140	1.680	140	740	40	
FMG131200	12,0	12	75	25	3	197,27	2.740	250	1.680	120	1.370	120	620	30	
FMG131600	16,0	16	90	32	3	326,93	2.200	200	1.360	100	1.050	100	460	25	
FMG131800	18,0	18	90	32	3	477,74	1.940	175	1.210	85	950	85	410	20	
FMG132000	20,0	20	100	28	4	541,78	1.680	150	1.060	70	840	70	350	20	
FMG132500	25,0	25	120	45	4	866,52	1.360	115	840	60	670	60	300	15	

NOTA: En operaciones de fresado por una cara deberemos aumentar los avances señalados en un 30%, manteniendo las mismas revoluciones.

TOLERANCIAS SEGÚN DIN 7160 y 7161

Gama de tolerancias μm / Diámetro nominal en mm					
	de 1 a 3	de 3 a 6	de 6 a 10	de 10 a 18	de 18 a 30
TOL e8	- 14	- 20	- 25	- 32	- 40
	- 28	- 38	- 47	- 59	- 73
TOL h6	0	0	0	0	0
	- 6	- 8	- 9	- 11	- 13

FRESAS 3 A 5 LABIOS, DESBASTE FINO

INOX

Ref. FMG15
Ref. FMG16

3-5 Z

MG
MD

NF

WELDON

TiAlN

INOX

45
HRc

Ti

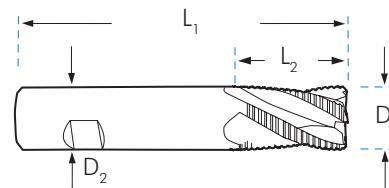

INC

SERIE CORTA

Micro Grano
MD

FMG15

REVOLUCIONES Y AVANCES

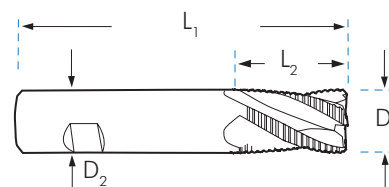

	TOL					€					INOX		INC	
	h10	h6	D1	D2	Z		R.P.M.	AVANCE	R.P.M.	AVANCE	R.P.M.	AVANCE	R.P.M.	AVANCE
	mm	mm	mm	mm			rev./min	mm/min	rev./min	mm/min	rev./min	mm/min	rev./min	mm/min
FMG150600	6,0	6	54	7	3	72,54	15.600	2.320	12.400	840	8.400	570	2.400	190
FMG150700	7,0	8	58	8	3	84,77	13.600	2.320	10.800	840	7.350	570	2.100	190
FMG150800	8,0	8	58	9	3	84,77	11.600	2.320	9.200	840	6.300	570	1.800	190
FMG150900	9,0	10	66	13	4	126,41	10.400	2.320	8.400	840	5.700	570	1.550	190
FMG151000	10,0	10	66	14	4	126,41	9.200	2.320	7.600	840	5.100	570	1.300	190
FMG151200	12,0	12	73	16	4	162,16	8.000	2.400	6.000	800	4.200	570	1.200	190
FMG151400	14,0	14	75	18	4	196,69	6.800	2.400	5.200	840	3.600	570	900	130
FMG151600	16,0	16	82	22	4	263,92	6.000	2.400	4.800	760	3.300	510	800	110
FMG151800	18,0	18	84	24	4	338,05	5.200	2.320	4.400	720	2.700	420	700	100
FMG152000	20,0	20	92	26	4	424,49	4.800	2.160	3.600	560	2.400	360	660	100
FMG152500	25,0	25	110	25	5	743,95	4.300	2.150	3.200	620	2.160	410	600	100

SERIE LARGA



FMG16





REVOLUCIONES Y AVANCES

	TOL					€					INOX		INC	
	h10	h6	D1	D2	Z		R.P.M.	AVANCE	R.P.M.	AVANCE	R.P.M.	AVANCE	R.P.M.	AVANCE
	mm	mm	mm	mm			rev./min	mm/min	rev./min	mm/min	rev./min	mm/min	rev./min	mm/min
FMG160600	6,0	6	57	16	3	77,95	15.600	2.320	12.400	840	8.400	570	2.400	190
FMG160700	7,0	8	63	16	3	91,11	13.600	2.320	10.800	840	7.350	570	2.100	190
FMG160800	8,0	8	63	16	3	91,11	11.600	2.320	9.200	840	6.300	570	1.800	190
FMG160900	9,0	9	72	19	4	135,88	10.400	2.320	8.400	840	5.700	570	1.550	190
FMG161000	10,0	10	72	22	4	135,88	9.200	2.320	7.600	840	5.100	570	1.300	190
FMG161200	12,0	12	83	26	4	174,35	8.000	2.400	6.000	800	4.200	570	1.200	190
FMG161400	14,0	14	83	26	4	211,44	6.800	2.400	5.200	840	3.600	570	900	130
FMG161600	16,0	16	92	32	4	283,75	6.000	2.400	4.800	760	3.300	510	800	110
FMG161800	18,0	18	92	32	4	363,46	5.200	2.320	4.400	720	2.700	420	700	100
FMG162000	20,0	20	104	38	4	456,40	4.800	2.160	3.600	560	2.400	360	660	100
FMG162500	25,0	25	121	45	5	799,91	4.300	2.150	3.200	620	2.160	410	600	100

TOLERANCIAS SEGÚN DIN 7160 y 7161

Gama de tolerancias μm / Diámetro nominal en mm					
	de 1 a 3	de 3 a 6	de 6 a 10	de 10 a 18	de 18 a 30
TOL e8	0 - 40	0 - 48	0 - 58	0 - 70	0 - 84
TOL h6	0 - 6	0 - 8	0 - 9	0 - 11	0 - 13



FRESA 4 A 6 LABIOS, SERIE CORTA, HÉLICE A 45°

INOX Ref. FMG17 **4-6 Z**   **MG MD**  **NF**  **WELDON** **TiAIN** **INOX** **45 HRc** **INC**

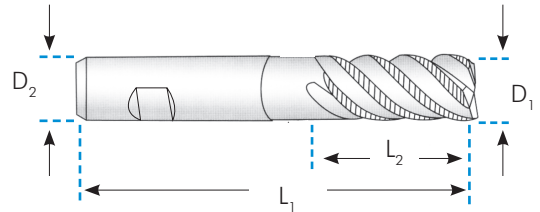

SERIE CORTA

Micro Grano MD



	FMG17						REVOLUCIONES Y AVANCES									
	TOL h10	TOL h6	D1 mm	D2 mm	L1 mm	L2 mm	Z	€					INOX		INC	
R.P.M. rev./min	AVANCE mm/min	R.P.M. rev./min							AVANCE mm/min	R.P.M. rev./min	AVANCE mm/min	R.P.M. rev./min	AVANCE mm/min	R.P.M. rev./min	AVANCE mm/min	R.P.M. rev./min
FMG170600	6,0	6	6,0	6,0	54	7	4	72,54	15.600	2.320	12.400	840	8.400	570	2.400	190
FMG170800	8,0	8	8,0	8,0	58	9	4	84,77	11.600	2.320	9.200	840	6.300	570	1.800	190
FMG171000	10,0	10	10,0	10,0	66	14	4	126,41	9.200	2.320	7.600	840	5.100	570	1.300	190
FMG171200	12,0	12	12,0	12,0	73	16	4	162,16	8.000	2.400	6.000	800	4.200	570	1.200	190
FMG171600	16,0	16	16,0	16,0	82	22	5	263,92	6.000	2.400	4.800	760	3.300	510	800	110
FMG172000	20,0	20	20,0	20,0	92	26	6	424,49	4.800	2.160	3.600	560	2.400	360	660	100



FRESA 3 A 6 LABIOS, SERIE LARGA, HÉLICE A 45°

INOX Ref. FMG18 **3-6 Z**   **MG MD**  **NF**  **WELDON** **TiAIN** **INOX** **45 HRc** **INC**

SERIE LARGA

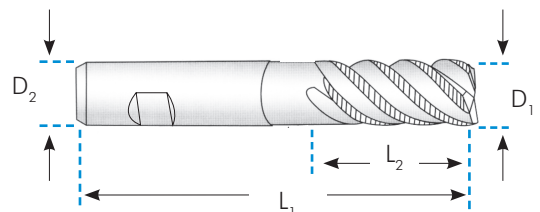
Micro Grano MD



	FMG18						REVOLUCIONES Y AVANCES									
	TOL h10	TOL h6	D1 mm	D2 mm	L1 mm	L2 mm	Z	€					INOX		INC	
R.P.M. rev./min	AVANCE mm/min	R.P.M. rev./min							AVANCE mm/min	R.P.M. rev./min	AVANCE mm/min	R.P.M. rev./min	AVANCE mm/min	R.P.M. rev./min	AVANCE mm/min	R.P.M. rev./min
FMG180400	4,0	6	4,0	6,0	57	11	3	75,68	20.100	4.600	18.400	1.700	12.600	1.040	3.800	399
FMG180500	5,0	6	5,0	6,0	57	13	4	75,68	18.000	4.600	15.000	1.650	10.200	1.040	2.200	390
FMG180600	6,0	6	6,0	6,0	57	16	4	75,68	15.600	2.320	12.400	840	8.400	570	2.400	190
FMG180700	7,0	8	7,0	8,0	63	16	4	88,45	13.600	2.320	10.800	840	7.350	570	2.100	190
FMG180800	8,0	8	8,0	8,0	63	16	4	88,45	11.600	2.320	9.200	840	6.300	570	1.800	190
FMG180900	9,0	10	9,0	10,0	72	19	4	131,92	10.400	2.320	8.400	840	5.700	570	1.550	190
FMG181000	10,0	10	10,0	10,0	72	22	4	131,92	9.200	2.320	7.600	840	5.100	570	1.300	190
FMG181200	12,0	12	12,0	12,0	83	26	4	169,27	8.000	2.400	6.000	800	4.200	570	1.200	190
FMG181400	14,0	14	14,0	14,0	83	26	5	205,28	6.800	2.400	5.200	840	3.600	570	900	130
FMG181600	16,0	16	16,0	16,0	92	32	5	275,49	6.000	2.400	4.800	760	3.300	510	800	110
FMG182000	20,0	20	20,0	20,0	104	38	6	443,11	4.800	2.160	3.600	560	2.400	360	660	100
FMG182500	25,0	25	25,0	25,0	121	45	6	776,61	4.300	2.150	3.200	620	2.160	410	600	100

FRESA 4 A 6 LABIOS, SERIE LARGA, HÉLICE A 45°

INOX

Ref. FMG19

4-6 Z

MG
MD45
HRc

SERIE LARGA

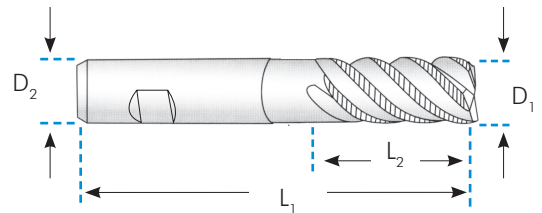
Micro Grano
MD

FMG19

REVOLUCIONES Y AVANCES

	TOL							€					INOX		INC		
	h10	h6	D1	D2	D3	L1	L2		L3	Z	R.P.M.	AVANCE	R.P.M.	AVANCE	R.P.M.	AVANCE	R.P.M.
	mm	mm	mm	mm	mm	mm	mm	mm		rev./min	mm/min	rev./min	mm/min	rev./min	mm/min	rev./min	mm/min
FMG190600	6,0	6	5,5	57	16	20	4	93,44	15.600	2.320	12.400	840	8.400	570	2.400	190	
FMG190800	8,0	8	7,5	63	16	26	4	109,24	11.600	2.320	9.200	840	6.300	570	1.800	190	
FMG191000	10,0	10	9,5	72	22	31	4	162,96	9.200	2.320	7.600	840	5.100	570	1.300	190	
FMG191200	12,0	12	11,5	83	26	37	4	209,10	8.000	2.400	6.000	800	4.200	570	1.200	190	
FMG191600	16,0	16	15,5	100	32	51	5	340,65	6.000	2.400	4.800	760	3.300	510	800	110	
FMG192000	20,0	20	19,2	110	38	59	6	547,59	4.800	2.160	3.600	560	2.400	360	660	100	

TOLERANCIAS SEGÚN DIN 7160 y 7161

Gama de tolerancias μm / Diámetro nominal en mm					
	de 1 a 3	de 3 a 6	de 6 a 10	de 10 a 18	de 18 a 30
TOL h10	0 - 40	0 - 48	0 - 58	0 - 70	0 - 84
TOL h6	0 - 6	0 - 8	0 - 9	0 - 11	0 - 13

FRESA 2 Y 3 LABIOS, SERIE CORTA, HÉLICE A 45°, PARA ALUMINIO

AI

MG
MD



45°
N
CILÍNDRICO

2Z



Ref. FMD59

3Z



Ref. FMD33

SERIE CORTA

Micro Grano
MD

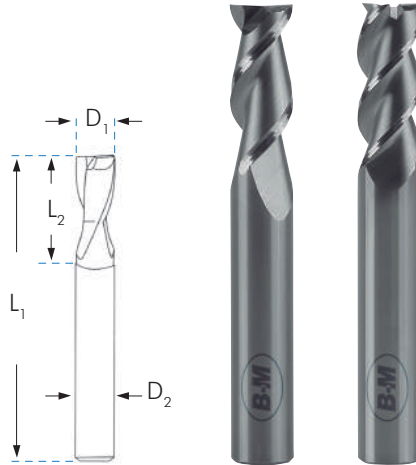

TOL -0,05	TOL h6			FMD59	FMD33		
		D1 mm	D2 mm	L1 mm	L2 mm	2Z	3Z
		3,0	6,0	50	8	23,18	23,18
		4,0	6,0	50	11	25,11	25,11
		5,0	6,0	50	13	25,95	25,95
		6,0	6,0	50	16	29,46	29,46
		8,0	8,0	60	19	41,98	41,98
		10,0	10,0	72	25	61,70	61,70
		12,0	12,0	75	30	81,54	81,54
		14,0	14,0	84	35	114,43	114,43
		16,0	16,0	92	40	145,13	145,13
		20,0	20,0	100	45	239,36	239,36

REVOLUCIONES Y AVANCES		
AI		
R.P.M. rev./min.	AVANCE 1 mm/min	AVANCE 2 mm/min
10.000	700	900
10.000	900	1.100
10.000	1.000	1.300
10.000	1.200	1.500
8.000	1.400	1.800
8.000	1.700	2.100
8.000	2.100	2.600
6.000	1.800	2.200
6.000	1.900	2.400
4.000	1.600	1.900

TOLERANCIAS SEGÚN DIN 7160 y 7161

Gama de tolerancias μm / Diámetro nominal en mm

	de 1 a 3	de 3 a 6	de 6 a 10	de 10 a 18	de 18 a 30
TOL	0	0	0	0	0
h10	-40	-48	-58	-70	-84
TOL	0	0	0	0	0
h6	-6	-8	-9	-11	-13

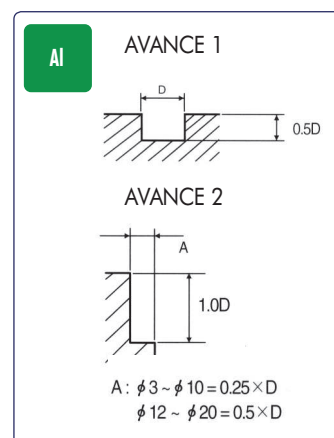

FRESAS ESPECIALES PARA ALUCOBOND

PMD

Ref. FFALUC

MDI

Ref. FFALUC...MDI

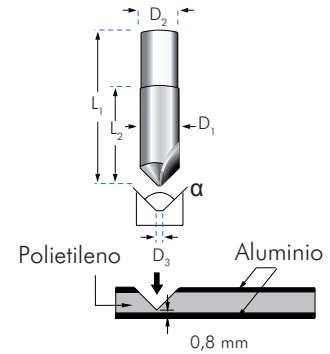
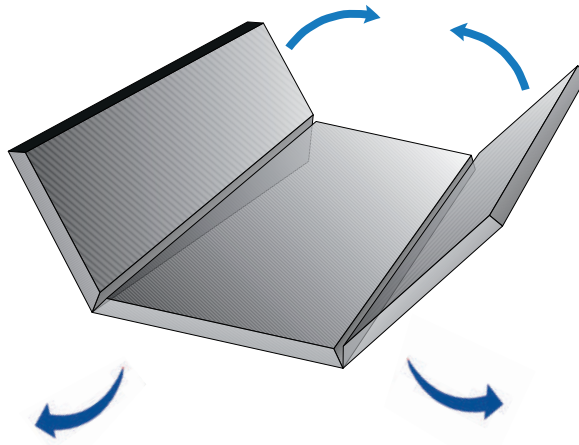
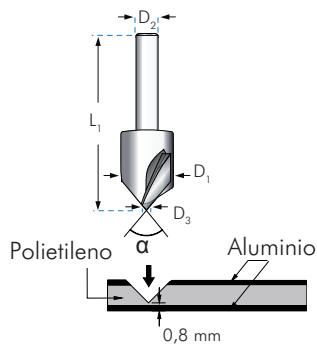

DE PLAQUITA SOLDADA

DE METAL DURO INTEGRAL

FFALUC						
	D1 mm	D2 mm	D3 mm	L1 mm	α	€
FFALUC1600	16,00	8	2,5	55	90°	148,90
FFALUC1800	18,00	8	2,5	55	90°	150,81
FFALUC2000	20,00	8	2,5	55	90°	155,26
FFALUC1600-135	16,00	8	2,3	55	135°	180,53
FFALUC1800-135	18,00	8	2,3	55	135°	187,27
FFALUC2000-135	20,00	8	2,3	55	135°	214,38

FFALUC...MDI							
	D1 mm	D2 mm	D3 mm	L1 mm	L2 mm	α	€
FFALUC1400MDI	14,00	14	2,5	50	14	90°	155,10
FFALUC1600MDI	16,00	16	2,5	50	16	90°	185,59
FFALUC1800MDI	18,00	18	2,5	50	18	90°	268,20
FFALUC1400MDI-135	14,00	14	0,5	50	14	135°	155,10
FFALUC1600MDI-135	16,00	16	0,5	50	16	135°	185,59
FFALUC1800MDI-135	18,00	18	0,5	50	18	135°	268,20

FRESAS DE METAL DURO FRONTALES CON CUELLO



Ref. FMG74
Ref. FMG75
Ref. FMG76

2 Z



MG
MD



30°



CILÍNDRICO

TiAlN



50
HRc

Micro Grano
MD

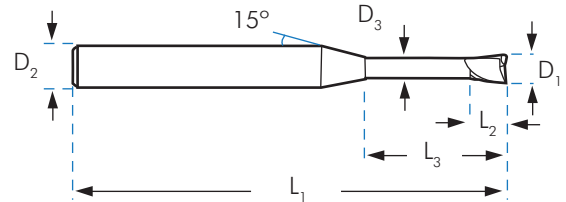

FMG74

	TOL -0,015	TOL h6					€
	D1 mm	D2 mm	D3 mm	L1 mm	L2 mm	L3 mm	
FMG740050	0,5	4	0,45	45	0,7	8	86,67
FMG740100	1,0	4	0,95	55	1,5	20	88,92
FMG740150	1,5	4	1,45	55	2,3	20	80,27
FMG740200	2,0	4	1,95	55	3,0	20	77,03
FMG740300	3,0	6	2,85	60	4,5	20	99,62
FMG740400	4,0	6	3,85	60	6,0	20	99,62
FMG740500	5,0	6	4,85	60	7,5	20	99,62
FMG740600	6,0	6	5,85	80	9,0	20	99,62

FMG75

	TOL -0,015	TOL h6					€
	D1 mm	D2 mm	D3 mm	L1 mm	L2 mm	L3 mm	
FMG750200	2,0	4	1,95	70	3,0	30	91,05
FMG750300	3,0	6	2,85	70	4,5	30	103,48
FMG750400	4,0	6	3,85	70	6,0	30	103,48
FMG750500	5,0	6	4,85	80	7,5	30	103,48
FMG750600	6,0	6	5,85	90	9,0	30	103,48

FMG76

	TOL -0,015	TOL h6					€
	D1 mm	D2 mm	D3 mm	L1 mm	L2 mm	L3 mm	
FMG760400	4,0	6	3,85	90	6,0	40	113,79
FMG760500	5,0	6	4,85	80	7,5	40	113,79
FMG760600	6,0	6	5,85	100	9,0	40	113,79

FRESAS DE METAL DURO SEMIESFÉRICAS CON CUELLO



Ref. FMG77
Ref. FMG78
Ref. FMG79

2 Z

MG
MD

30°



CILÍNDRICO

TiAlN

50
HRc

Micro Grano
MD

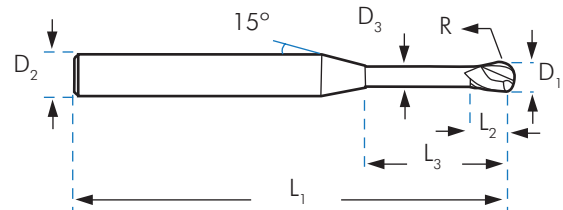

R : ± 0,01 mm

FMG77

	TOL -0,02	TOL h6					€
	D1 mm	D2 mm	D3 mm	L1 mm	L2 mm	L3 mm	
FMG770050	0,5	4	0,45	45	0,7	8	86,67
FMG770100	1,0	4	0,95	55	1,5	20	88,92
FMG770150	1,5	4	1,45	55	2,3	20	80,27
FMG770200	2,0	4	1,95	55	3,0	20	77,03
FMG770300	3,0	6	2,85	60	4,5	20	99,62
FMG770400	4,0	6	3,85	65	6,0	20	99,62
FMG770500	5,0	6	4,85	60	7,5	20	99,62
FMG770600	6,0	6	5,85	80	9,0	20	99,62

FMG78

	TOL -0,02	TOL h6					€
	D1 mm	D2 mm	D3 mm	L1 mm	L2 mm	L3 mm	
FMG780200	2,0	4	1,95	70	3,0	30	91,05
FMG780300	3,0	6	2,85	70	4,5	30	103,48
FMG780400	4,0	6	3,85	70	6,0	30	103,48
FMG780500	5,0	6	4,85	80	7,5	30	103,48
FMG780600	6,0	6	5,85	90	9,0	30	103,48

FMG79

	TOL -0,02	TOL h6					€
	D1 mm	D2 mm	D3 mm	L1 mm	L2 mm	L3 mm	
FMG790400	4,0	6	3,85	90	6,0	40	113,79
FMG790600	6,0	6	5,85	100	9,0	40	113,79

FRESA DE 2 LABIOS PARA ACEROS DE TEMPLE EXTREMO 70HRC



Ref. FMG01

2 Z



MG MD



CILÍNDRICO

BLUE

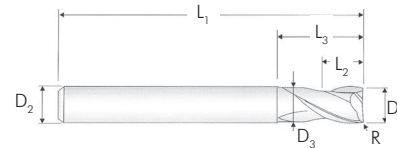

Micro Grano MD

FMG01

REVOLUCIONES Y AVANCES

	TOL Especial		TOL h6					€	50-55 HRc		55-60 HRc		60-65 HRc		65-70 HRc	
	D1 mm	D2 mm	D3 mm	L1 mm	L2 mm	L3 mm	R		R.P.M. rev./min.	AVANCE mm/min	R.P.M. rev./min.	AVANCE mm/min	R.P.M. rev./min.	AVANCE mm/min	R.P.M. rev./min.	AVANCE mm/min
FMG010100	1,0	3	-	40	1,5	-	0,1	55,15	25.500	360	20.500	215	16.000	135	12.500	88
FMG010150	1,5	3	-	40	2,2	-	0,1	55,15	21.500	390	17.500	240	13.500	150	11.000	102
FMG010200	2,0	3	1,9	40	3,0	6	0,1	50,03	17.500	420	14.500	260	11.000	160	9.500	115
FMG010250	2,5	3	2,4	40	4,0	6	0,1	50,03	14.500	420	12.000	260	9.250	160	7.950	115
FMG010300	3,0	6	2,9	45	4,0	7	0,1	73,07	11.500	420	9.500	260	7.500	160	6.400	115
FMG010350	3,5	6	3,3	45	5,0	9	0,1	73,07	10.150	430	8.350	270	6.550	165	5.575	118
FMG010400	4,0	6	3,8	45	5,0	9	0,1	73,07	8.800	440	7.200	270	5.600	170	4.750	118
FMG010450	4,5	6	4,3	45	6,0	10	0,1	73,07	8.550	470	6.800	280	5.350	175	4.600	125
FMG010500	5,0	6	4,8	50	6,0	11	0,2	73,07	8.300	500	6.400	285	5.100	180	4.450	132
FMG010600	6,0	6	5,8	50	7,0	14	0,2	73,07	6.900	480	5.300	280	4.200	180	3.700	130
FMG010800	8,0	8	7,8	60	9,0	18	0,2	92,40	5.200	445	4.000	255	3.200	165	2.800	120
FMG011000	10,0	10	9,7	75	12,0	25	0,2	138,11	4.100	415	3.200	240	2.550	155	2.200	112
FMG011200	12,0	12	11,7	75	15,0	30	0,3	190,45	3.500	415	2.650	240	2.100	155	1.860	112
FMG011600	16,0	16	15,7	90	18,0	38	0,3	317,52	2.600	365	2.000	210	1.600	135	1.400	98
FMG012000	20,0	20	19,7	100	24,0	45	0,3	525,01	2.050	335	1.600	295	1.300	125	1.100	88

FRESA DE 4 LABIOS PARA ACEROS DE TEMPLE EXTREMO 70HRC



Ref. FMG04

4 Z



MG MD



CILÍNDRICO

BLUE

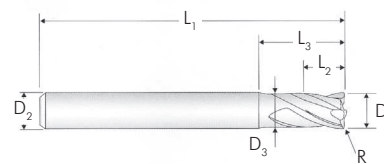

Micro Grano MD

FMG04

REVOLUCIONES Y AVANCES

	TOL Especial		TOL h6					€	50-55 HRc		55-60 HRc		60-65 HRc		65-70 HRc	
	D1 mm	D2 mm	D3 mm	L1 mm	L2 mm	L3 mm	R		R.P.M. rev./min.	AVANCE mm/min	R.P.M. rev./min.	AVANCE mm/min	R.P.M. rev./min.	AVANCE mm/min	R.P.M. rev./min.	AVANCE mm/min
FMG040100	1,0	3	-	40	1,5	-	0,1	55,15	25.500	710	20.500	430	16.000	270	12.500	175
FMG040150	1,5	3	-	40	2,2	-	0,1	55,15	21.500	775	17.500	475	13.500	295	11.000	200
FMG040200	2,0	3	1,9	40	3,0	6	0,1	50,03	17.500	840	14.500	520	11.000	320	9.500	230
FMG040250	2,5	3	2,4	40	4,0	6	0,1	50,03	14.500	840	12.000	520	9.250	320	7.950	230
FMG040300	3,0	6	2,9	45	4,0	7	0,1	73,07	11.500	840	9.500	520	7.500	320	6.400	230
FMG040350	3,5	6	3,3	45	5,0	9	0,1	73,07	10.150	860	8.350	530	6.550	328	5.575	240
FMG040400	4,0	6	3,8	45	5,0	9	0,1	73,07	8.800	880	7.200	540	5.600	335	4.750	240
FMG040450	4,5	6	4,3	45	6,0	10	0,1	73,07	8.550	940	6.800	560	5.350	353	4.600	255
FMG040500	5,0	6	4,8	50	6,0	11	0,2	73,07	8.300	1.000	6.400	580	5.100	370	4.450	270
FMG040600	6,0	6	5,8	50	7,0	14	0,2	73,07	6.900	950	5.300	560	4.200	350	3.700	260
FMG040800	8,0	8	7,8	60	9,0	18	0,2	92,40	5.200	900	4.000	520	3.200	330	2.800	240
FMG041000	10,0	10	9,7	75	12,0	25	0,2	138,11	4.100	840	3.200	480	2.550	310	2.200	220
FMG041200	12,0	12	11,7	75	15,0	30	0,3	190,45	3.500	840	2.650	480	2.100	300	1.860	220
FMG041600	16,0	16	15,7	90	18,0	38	0,3	317,52	2.600	730	2.000	420	1.600	270	1.400	200
FMG042000	20,0	20	19,7	100	24,0	45	0,3	525,01	2.050	650	1.600	380	1.300	250	1.100	180

FRESA DE 2 LABIOS SEMIESFÉRICA PARA ACEROS DE TEMPLE EXTREMO 70HRc



Ref. FMG02

2 Z

MG
MD

30°

CILÍNDRICO

BLUE

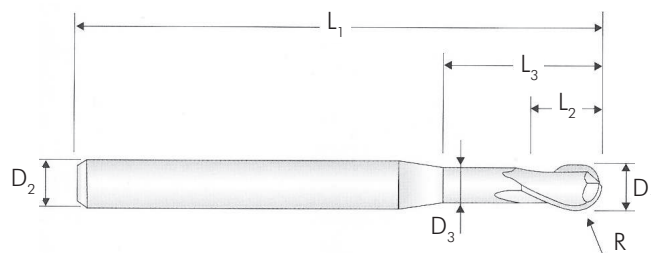

SERIE CORTA

Micro Grano
MD

FMG02

	TOL Especial		TOL h6		TOL R			€
	D1	D2	D3	L1	L2	L3	R	
	mm	mm	mm	mm	mm	mm	mm	
FMG020100	1,0	4	0,95	50	1,0	2,2	0,5	90,93
FMG020120	1,2	4	1,10	50	1,2	2,6	0,6	90,93
FMG020150	1,5	4	1,40	50	1,5	3,0	0,8	90,93
FMG020200	2,0	4	1,90	50	2,0	4,0	1,0	86,36
FMG020300	3,0	6	2,90	60	3,0	6,0	1,5	86,36
FMG020400	4,0	6	3,30	70	4,0	8,0	2,0	90,24
FMG020500	5,0	6	4,90	80	5,0	10,0	2,5	92,93
FMG020600	6,0	6	5,90	90	6,0	12,0	3,0	99,65
FMG020700	7,0	8	6,90	90	7,0	14,0	3,5	157,10
FMG020800	8,0	8	7,90	100	8,0	16,0	4,0	155,49
FMG020900	9,0	10	8,90	100	9,0	18,0	4,5	256,45
FMG021000	10,0	10	9,90	100	10,0	20,0	5,0	256,45
FMG021200	12,0	12	11,90	110	12,0	24,0	6,0	329,19
FMG021400	14,0	14	13,80	110	14,0	28,0	7,0	416,28
FMG021600	16,0	16	15,80	140	16,0	32,0	8,0	549,53
FMG021800	18,0	18	17,80	140	18,0	36,0	9,0	593,39
FMG022000	20,0	20	19,80	160	20,0	40,0	10,0	840,96
FMG022500	25,0	25	24,80	180	25,0	50,0	12,5	1.363,19

REVOLUCIONES Y AVANCES

	50-55 HRc		55-60 HRc		60-65 HRc		65-70 HRc	
	R.P.M	AVANCE	R.P.M	AVANCE	R.P.M	AVANCE	R.P.M	AVANCE
	rev./min.	mm/min	rev./min.	mm/min	rev./min.	mm/min	rev./min.	mm/min
FMG020100	57.000	4.000	54.000	3.400	51.000	2.700	48.000	2.300
FMG020120	52.750	4.000	50.000	3.300	46.000	2.700	43.000	2.300
FMG020150	48.500	4.000	44.500	3.275	41.500	2.750	38.250	2.300
FMG020200	40.000	4.000	35.000	3.150	32.000	2.800	28.500	2.300
FMG020300	26.500	4.000	23.500	3.150	21.000	2.800	19.000	2.300
FMG020400	20.000	4.000	17.500	3.150	16.000	2.800	14.500	2.300
FMG020500	15.000	3.750	13.500	3.050	11.500	2.550	10.500	2.100
FMG020600	11.000	3.100	10.000	2.500	8.800	2.150	8.000	1.750
FMG020700	10.000	2.900	9.000	2.325	7.900	2.000	7.250	1.650
FMG020800	9.000	2.700	8.000	2.150	7.000	1.850	6.500	1.550
FMG020900	8.250	2.500	7.300	2.025	6.400	1.750	5.900	1.465
FMG021000	7.500	2.400	6.600	1.900	5.800	1.650	5.300	1.380
FMG021200	5.600	1.900	5.000	1.550	4.400	1.250	4.000	1.050
FMG021400	5.000	1.800	4.500	1.450	3.950	1.125	3.600	950
FMG021600	4.500	1.700	4.000	1.350	3.500	1.000	3.200	850
FMG021800	4.000	1.600	3.600	1.275	3.150	900	2.875	750
FMG022000	3.600	1.500	3.200	1.200	2.800	800	2.550	660
FMG022500	-	-	-	-	-	-	-	-

TOLERANCIAS SEGÚN DIN 7160 y 7161

	Gama de tolerancias μm / Diámetro nominal en mm				
	de 1 a 3	de 3 a 6	de 6 a 10	de 10 a 18	de 18 a 30
TOL Especial	0 - 12	0 - 12	0 - 15	0 - 15	0 - 15
TOL h6	0 - 6	0 - 8	0 - 9	0 - 11	0 - 13
TOL R	0 - 5	0 - 10	0 - 10	0 - 10	0 - 10

FRESAS DE 6 LABIOS PARA ACEROS DE TEMPLE EXTREMO 70HRc

70 HRc Ref. FMG06

6 Z

MG MD

45°

CILÍNDRICO

BLUE

70 HRc

SERIE CORTA

Micro Grano MD

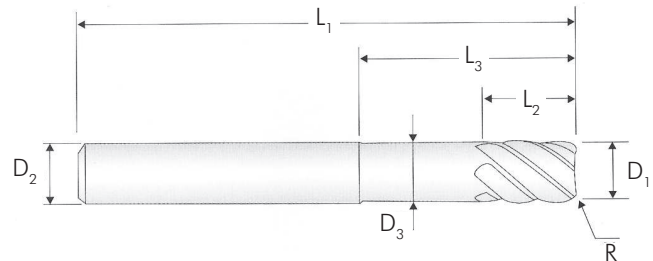

FMG06								REVOLUCIONES Y AVANCES								
TOL Especial	TOL h6			TOL R			€	50-55 HRc	55-60 HRc	60-65 HRc	65-70 HRc	50-55 HRc	55-60 HRc	60-65 HRc	65-70 HRc	
	D1 mm	D2 mm	D3 mm	L1 mm	L2 mm	L3 mm	R	€	R.P.M rev./min.	AVANCE 1 mm/min	R.P.M rev./min.	AVANCE 1 mm/min	R.P.M rev./min.	AVANCE 1 mm/min	R.P.M rev./min.	AVANCE 1 mm/min
FMG060600	6,0	6	5,70	50	6	14	0,5	104,53	16.000	4.900	13.500	3.300	10.500	2.100	8.000	1.450
FMG060800	8,0	8	7,65	60	8	24	0,5	124,69	12.000	4.600	10.000	3.100	8.000	2.000	6.000	1.400
FMG061000	10,0	10	9,65	70	10	30	1,0	194,51	9.500	4.100	8.000	2.900	6.400	1.800	4.800	1.300
FMG061200	12,0	12	11,60	75	12	30	1,0	232,33	8.000	3.800	6.600	2.500	5.300	1.600	4.000	1.150

SERIE LARGA

FMG07							REVOLUCIONES Y AVANCES								
TOL Especial	TOL h6			TOL R			€	50-55 HRc	55-60 HRc	60-65 HRc	65-70 HRc	50-55 HRc	55-60 HRc	60-65 HRc	65-70 HRc
	D1 mm	D2 mm	L1 mm	L2 mm	R	€	€	R.P.M rev./min.	AVANCE 1 mm/min	R.P.M rev./min.	AVANCE 1 mm/min	R.P.M rev./min.	AVANCE 1 mm/min	R.P.M rev./min.	AVANCE 1 mm/min
FMG070600	6,0	6	70	13	0,5	118,77	118,77	16.000	4.900	13.500	3.300	10.500	2.100	8.000	1.450
FMG070800	8,0	8	90	19	0,5	148,86	148,86	12.000	4.600	10.000	3.100	8.000	2.000	6.000	1.400
FMG071000	10,0	10	100	22	0,5	224,28	224,28	9.500	4.100	8.000	2.900	6.400	1.800	4.800	1.300
FMG071001	10,0	10	100	22	1,0	224,28	224,28	9.500	4.100	8.000	2.900	6.400	1.800	4.800	1.300
FMG071200	12,0	12	110	26	0,5	305,91	305,91	8.000	3.800	6.600	2.500	5.300	1.600	4.000	1.150
FMG071201	12,0	12	110	26	1,0	305,91	305,91	8.000	3.800	6.600	2.500	5.300	1.600	4.000	1.150
FMG071600	16,0	16	130	32	1,0	515,88	515,88	6.000	3.400	5.000	2.300	4.000	1.250	3.000	870
FMG071601	16,0	16	130	32	1,5	563,41	563,41	6.000	3.400	5.000	2.300	4.000	1.250	3.000	870
FMG072000	20,0	20	140	38	1,0	754,96	754,96	4.800	3.200	4.000	2.100	3.200	1.020	2.400	690
FMG072001	20,0	20	140	38	1,5	824,72	824,72	4.800	3.200	4.000	2.100	3.200	1.020	2.400	690
FMG072002	20,0	20	140	38	2,0	824,72	824,72	4.800	3.200	4.000	2.100	3.200	1.020	2.400	690

TOLERANCIAS SEGÚN DIN 7160 y 7161

Gama de tolerancias μm / Diámetro nominal en mm

	de 1 a 3	de 3 a 6	de 6 a 10	de 10 a 18	de 18 a 30
TOL Especial	0	0	0	0	0
	- 12	- 12	- 15	- 15	- 15
TOL h6	0	0	0	0	0
	- 6	- 8	- 9	- 11	- 13

FRESAS PARA ACEROS DE TEMPLE EXTREMO 70HRC, TECNOLOGÍA DE MICROFRESADO PIEZAS DE PRECISIÓN



Ref. FMG09

2 Z

MG
MD

30°



CILÍNDRICO

BLUE

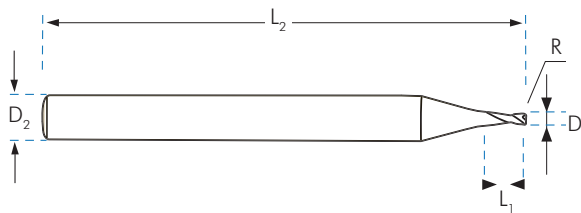
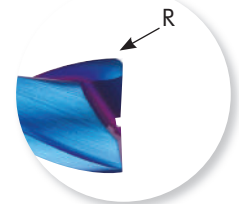
70
HRcTOL D1
-0,012TOL D2
h6Micro Grano
MD

FMG09

	D1 mm	D2 mm	L1 mm	L2 mm	R	€
FMG090030	0,30	6	50	0,45	-	96,72
FMG090040	0,40	6	50	0,60	-	90,76
FMG090050	0,50	6	50	0,70	0,05	78,95
FMG090060	0,60	6	50	0,90	0,05	75,96
FMG090080	0,80	6	50	1,20	0,05	69,99
FMG090100	1,00	6	50	1,50	0,10	67,07
FMG090120	1,20	6	50	1,80	0,10	67,07
FMG090150	1,50	6	50	2,20	0,15	67,07
FMG090200	2,00	6	50	2,20	0,15	60,80



Ref. FMG08

2 Z

MG
MD

30°



CILÍNDRICO

BLUE

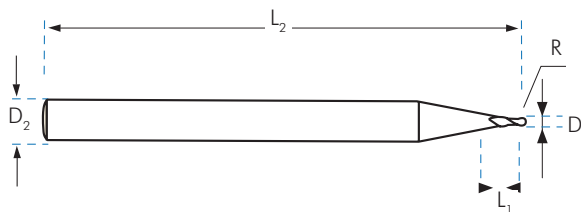
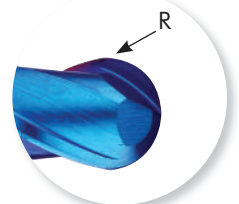
70
HRcTOL D1
-0,012TOL D2
h6Micro Grano
MD

FMG08

	D1 mm	D2 mm	L1 mm	L2 mm	R	€
FMG080040	0,40	6	50	0,40	0,20	98,16
FMG080050	0,50	6	50	0,50	0,25	90,62
FMG080060	0,60	6	50	0,60	0,30	83,09
FMG080080	0,80	6	50	0,80	0,40	67,77
FMG080100	1,00	6	50	1,00	0,50	63,81
FMG080120	1,20	6	50	1,20	0,60	63,81
FMG080150	1,50	6	50	1,50	0,75	63,81
FMG080200	2,00	6	50	2,00	1,00	57,81

FRESAS

DE AGUJERO

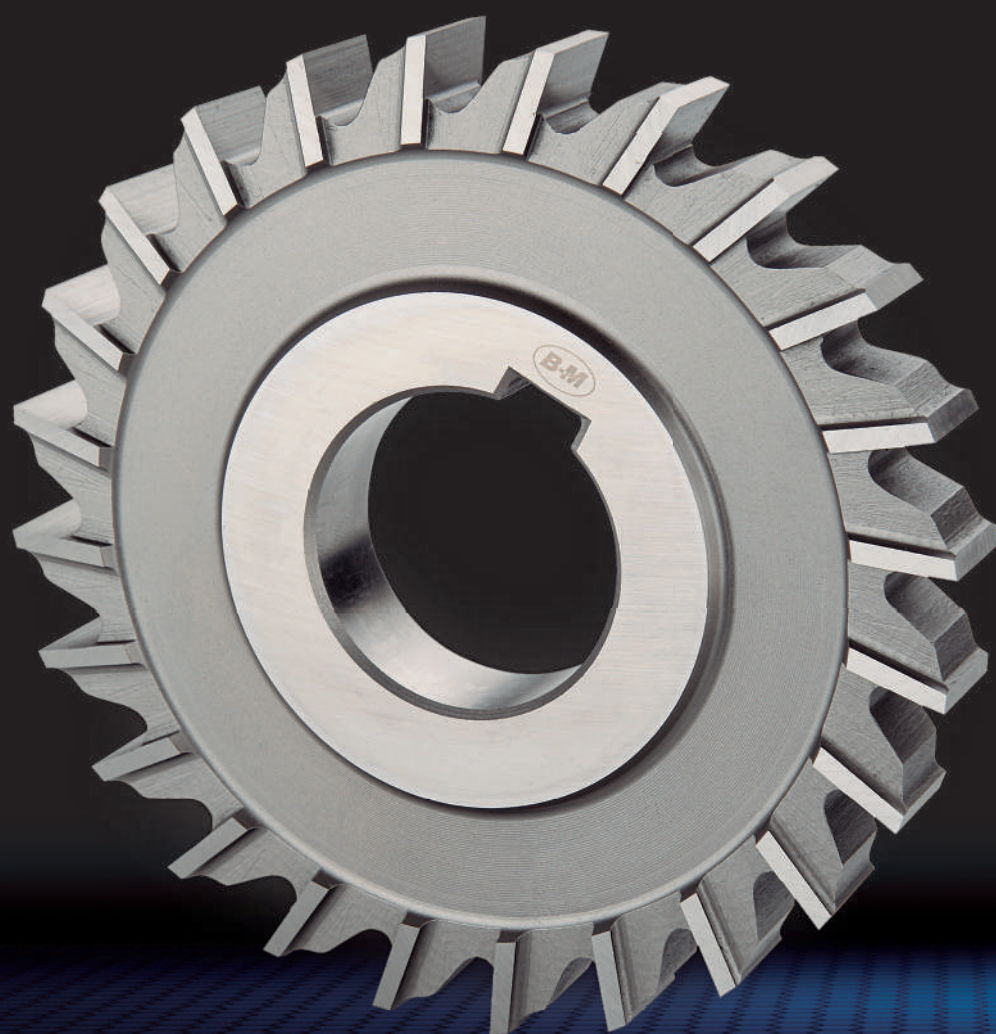

FRESA PARA RANURAR HSSCo DE 3 CORTES CON DIENTE CRUZADO

Ref. FF56

HSSCo

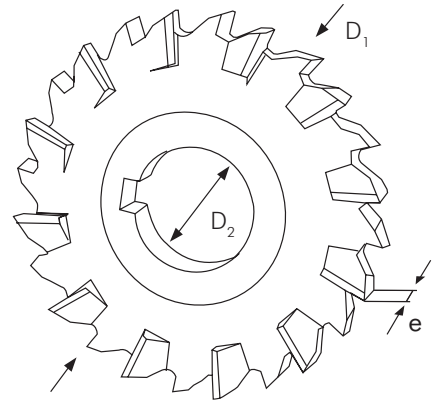
DIN
885A

FF56				
D1 mm	e mm	D2 mm	Z	€
50	4,0	16	12	83,22
50	5,0	16	12	83,22
50	6,0	16	12	96,44
50	8,0	16	12	93,92
50	10,0	16	12	103,43
63	1,6	22	16	199,01
63	2,0	22	16	176,20
63	2,5	22	16	179,87
63	3,0	22	16	184,80
63	4,0	22	12	96,03
63	5,0	22	12	96,03
63	6,0	22	12	98,74
63	8,0	22	12	107,60
63	10,0	22	12	115,78
63	12,0	22	12	123,63
63	14,0	22	12	133,16
63	16,0	22	12	140,16
63	18,0	22	12	167,45
80	1,6	27	20	198,90
80	2,0	27	20	193,21
80	2,5	27	20	196,42
80	3,0	27	20	192,53
80	4,0	27	20	206,29
80	5,0	27	14	130,46
80	6,0	27	14	133,54
80	8,0	27	14	140,92
80	10,0	27	14	150,82
80	12,0	27	14	161,45
80	14,0	27	14	172,63
80	16,0	27	14	176,62
80	18,0	27	14	189,46
80	20,0	27	14	208,32

FF56				
D1 mm	e mm	D2 mm	Z	€
100	1,6	32	24	237,94
100	2,0	32	24	236,65
100	2,5	32	24	236,43
100	3,0	32	24	229,55
100	4,0	32	24	247,47
100	5,0	32	24	262,35
100	6,0	32	16	183,38
100	8,0	32	16	187,26
100	10,0	32	16	194,12
100	12,0	32	16	209,09
100	14,0	32	16	230,19
100	16,0	32	16	241,44
100	18,0	32	16	266,13
100	20,0	32	16	266,13
100	22,0	32	16	298,33
100	25,0	32	16	324,52
125	1,6	32	26	300,92
125	2,0	32	26	289,43
125	2,5	32	26	296,64
125	3,0	32	26	303,85
125	4,0	32	26	325,52
125	5,0	32	26	348,44
125	6,0	32	26	357,05
125	8,0	32	18	289,23
125	10,0	32	18	296,78
125	12,0	32	18	308,03
125	14,0	32	18	334,51
125	16,0	32	18	355,19
125	18,0	32	18	375,71
125	20,0	32	18	399,74
125	22,0	32	18	455,16
125	25,0	32	18	459,56
125	28,0	32	18	502,30

FF56				
D1 mm	e mm	D2 mm	Z	€
160	2,0	40	30	484,34
160	2,5	40	30	466,27
160	3,0	40	30	475,24
160	4,0	40	30	502,16
160	5,0	40	30	531,77
160	6,0	40	30	570,97
160	8,0	40	30	651,70
160	10,0	40	22	479,41
160	12,0	40	22	479,41
160	14,0	40	22	477,07
160	16,0	40	22	522,10
160	18,0	40	22	550,14
160	20,0	40	22	564,71
160	22,0	40	22	620,71
160	25,0	40	22	672,58
160	28,0	40	22	739,33
160	32,0	40	22	790,49
200	12,0	40	24	731,29
200	14,0	40	24	738,45
200	16,0	40	24	760,78
200	18,0	40	24	798,22
200	20,0	40	24	853,70
200	22,0	40	24	856,51
200	25,0	40	24	993,53
200	28,0	40	24	1.024,94
200	32,0	40	24	1.278,25

FRESA PARA RANURAR HSSCo DE 3 CORTES CON DIENTE RECTO



Ref. FF59

HSSCo

**DIN
885B**

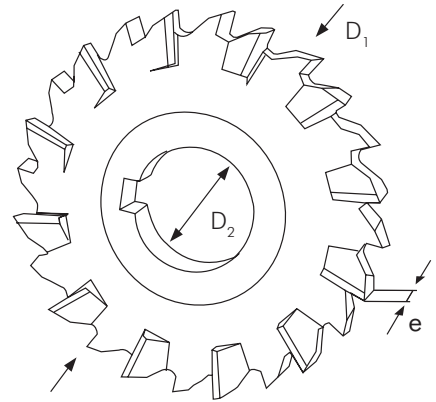

Fresas

Rosa

FF59				
D1 mm	e mm	D2 mm	Z	€
50	4	16	16	82,96
50	5	16	16	82,96
50	6	16	16	96,15
50	8	16	16	93,64
50	10	16	16	103,11
63	4	22	18	96,65
63	5	22	18	96,65
63	6	22	18	97,93
63	8	22	18	106,47
63	10	22	18	114,57
63	12	22	18	122,71
63	14	22	18	132,16
63	16	22	18	139,79
63	18	22	18	166,95
80	5	27	20	130,01
80	6	27	20	133,43
80	8	27	20	140,82
80	10	27	20	150,32
80	12	27	20	160,94
80	14	27	20	172,12
80	16	27	20	176,59
80	18	27	20	189,42
80	20	27	20	208,28

FF59				
D1 mm	e mm	D2 mm	Z	€
100	6	32	22	181,52
100	8	32	22	186,68
100	10	32	22	193,50
100	12	32	22	208,39
100	14	32	22	229,45
100	16	32	22	243,09
100	18	32	22	266,08
100	20	32	22	266,08
100	22	32	22	297,43
100	25	32	22	325,36
125	8	32	24	289,07
125	10	32	24	296,60
125	12	32	24	307,85
125	14	32	24	334,32
125	16	32	24	351,48
125	18	32	24	375,60
125	20	32	24	399,62
125	22	32	24	455,04
125	25	32	24	459,45
125	28	32	24	502,15

FF59				
D1 mm	e mm	D2 mm	Z	€
160	10	40	28	479,27
160	12	40	28	479,27
160	14	40	28	476,93
160	16	40	28	521,94
160	18	40	28	549,98
160	20	40	28	564,55
160	22	40	28	620,53
160	25	40	28	672,39
160	28	40	28	739,12
160	32	40	28	790,26
200	12	40	30	731,08
200	14	40	30	738,24
200	16	40	30	760,57
200	18	40	30	798,00
200	20	40	30	853,46
200	22	40	30	856,28
200	25	40	30	993,26
200	28	40	30	1.024,65
200	32	40	30	1.277,89

FRESA DE MÓDULO PARA TALLADO DE ENGRANAJES

HSS

Ref. 99RFM

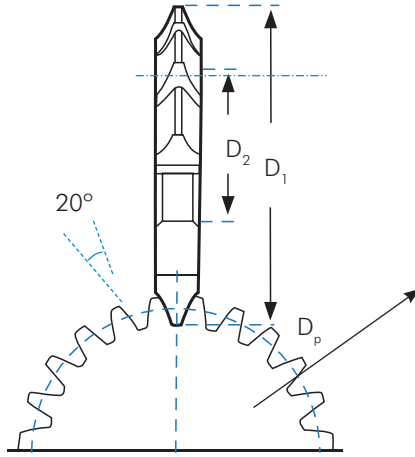

MÓDULO FRESA	D ₁ mm	D ₂ mm	99RFM €
0,50	40	16	94,13
0,70	40	16	94,13
0,75	40	16	94,13
0,80	40	16	94,13
1,00	50	16	94,13
1,25	50	16	94,13
1,50	56	22	94,13
1,75	56	22	94,13
2,00	63	22	94,13
2,25	63	22	110,32
2,50	63	22	110,32
2,75	71	27	110,32
3,00	71	27	110,32
3,25	71	27	145,58
3,50	80	27	145,58
3,75	80	27	145,58
4,00	80	27	145,58
4,50	90	32	199,54
5,00	90	32	199,54
6,00	100	32	252,66
7,00	100	32	252,66

NÚMERO DE FRESA / DIENTES A TALLAR

Nº1	Nº2	Nº3	Nº4	Nº5	Nº6	Nº7	Nº8	Set
12-13	14-16	17-20	21-25	26-34	35-54	55-134	135-∞	12-∞

$$\text{Mód.} = \frac{\text{ØEst}}{(Z+2)}$$

NOTA: El precio depende del módulo, independientemente del nº de dientes a tallar.

FRESAS CILÍNDRICAS, FRONTALES CON CHAVETERO TRANSVERSAL HSSCo

Ref. FF87

HSSCo

DIN
1880

ACABADO

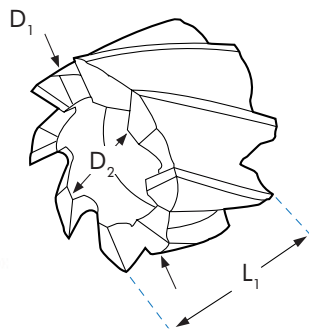

Ref. FF88

HSSCo

DIN
1880

NR

DESBASTE

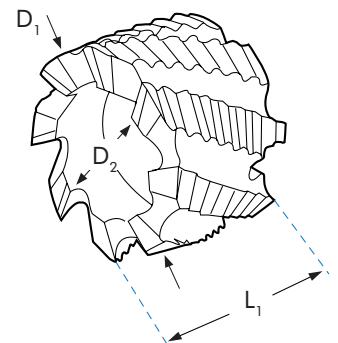

FF87				
D ₁ mm	D ₂ mm	L ₁ mm	Z	€
40	16	32	8	109,44
50	22	36	8	150,58
63	27	40	8	205,76
80	27	45	10	291,23
100	32	50	12	468,85
125	40	56	14	752,93
160	50	63	16	1.345,65

FF88				
D ₁ mm	D ₂ mm	L ₁ mm	Z	€
40	16	32	6	158,51
50	22	36	6	196,83
63	27	40	8	260,79
80	27	45	8	383,32
100	32	50	10	632,43
125	40	56	12	1.072,92
160	50	63	14	1.861,69

FRESAS CILÍNDRICAS, FRONTALES CON CHAVETERO TRANSVERSAL HSSCo



Ref. FF89

HSSCo

DIN
884



CILÍNDRICA PARA PLANEAR

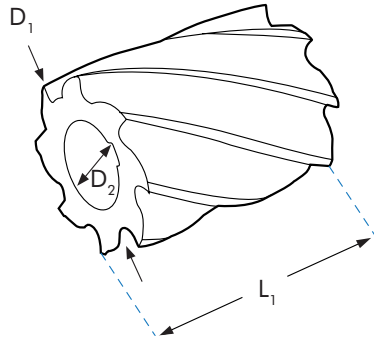
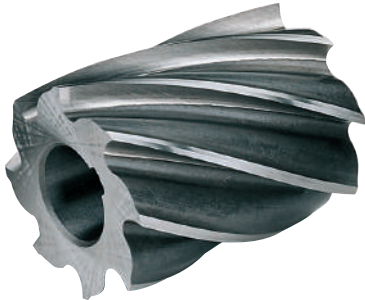

FF89				
D1 mm	D2 mm	L1 mm	Z	€
50	22	40	8	128,69
50	22	63	8	137,12
50	22	80	8	204,40
63	27	50	8	179,94
63	27	70	8	218,91
80	32	63	8	303,27
80	32	100	8	445,83
100	40	70	10	471,84

FRESAS CILÍNDRICAS, FRONTALES PARA PLANEAR CON MANGO



Ref. FMF87

HSSCo
8%



ACABADO

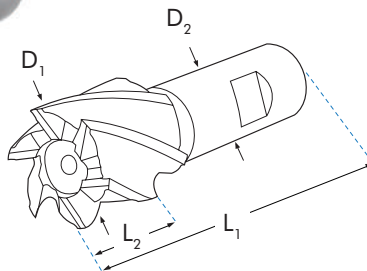

FMF87					
D1 mm	L2 mm	L1 mm	D2 mm	Z	€
30	30	90	20	6	159,54
35	30	90	20	6	183,10
40	32	95	25	8	228,20



Ref. FMF88

HSSCo
8%



DESBASTE

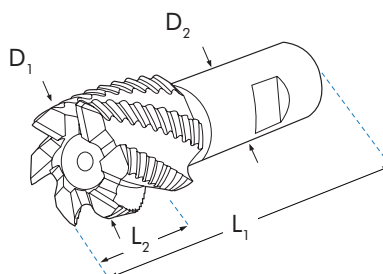

FMF88					
D1 mm	L2 mm	L1 mm	D2 mm	Z	€
30	30	90	20	6	184,43
35	30	90	20	6	236,28
40	32	95	25	8	289,45

FRESAS ANGULARES ISÓSCELES HSSCo

Ref. FF77	HSSCo	DIN 847	45°	Ref. FF78	HSSCo	DIN 847	60°	Ref. FF79	HSSCo	DIN 847	90°
-----------	-------	---------	-----	-----------	-------	---------	-----	-----------	-------	---------	-----

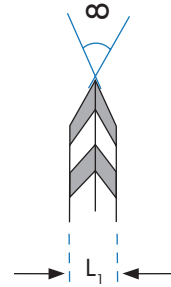
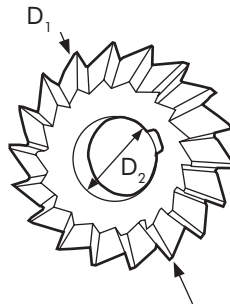

FF77						FF78						FF79					
D ₁ mm	D ₂ mm	L ₁ mm	∞	Z	€	D ₁ mm	D ₂ mm	L ₁ mm	∞	Z	€	D ₁ mm	D ₂ mm	L ₁ mm	∞	Z	€
50	16	8	45°	20	146,10	50	16	10	60°	18	148,96	50	16	14	90°	16	148,96
63	22	10	45°	22	173,78	63	22	14	60°	20	177,19	63	22	20	90°	18	177,19
80	27	12	45°	24	242,62	80	27	18	60°	22	247,38	80	27	22	90°	20	247,38
100	32	18	45°	26	303,32	100	32	25	60°	24	309,28	100	32	32	90°	22	309,28

FRESAS ANGULARES FRONTALES HSSCo

Ref. FF91	HSSCo	DIN 842	50°	Ref. FF90	HSSCo	DIN 842	60°
-----------	-------	---------	-----	-----------	-------	---------	-----

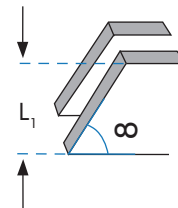
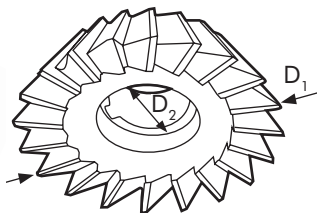

FF91						FF90					
D ₁ mm	D ₂ mm	L ₁ mm	∞	Z	€	D ₁ mm	D ₂ mm	L ₁ mm	∞	Z	€
40	10	13	50°	14	115,52	40	10	13	60°	14	113,27
50	13	16	50°	16	142,45	50	13	16	60°	16	139,69
63	16	20	50°	18	180,08	63	16	20	60°	18	176,58
80	22	25	50°	20	259,44	80	22	25	60°	20	254,42
100	27	32	50°	22	376,29	100	27	32	60°	22	368,97
125	32	40	50°	24	621,39	125	32	40	60°	24	609,34
160	40	50	50°	30	1.086,97	160	40	50	60°	30	1.065,88

FRESAS LLAVES



HERRAMIENTAS PARA CERRAJEROS LA MAS AMPLIA GAMA DE HERRAMIENTAS DE CORTE PARA CERRAJERÍA

Ref. BC5

DIN
338HSSCo
5%

DORADO

120
Kg/mm²

Broca fabricada en HSSCo según norma DIN 338 para metales de 120 Kg/mm² dureza.

Broca de ALTA DUREZA para USOS GENERALES en cerrajería. Encuéntrenla en la página 42.

Ref. BC7

DIN
338

PMD



BRILLANTE



FUNDICIÓN



Broca DIN 338 con punta de metal duro para METALES DUROS. Broca de ALTA DUREZA para taladrado de METALES DUROS en cerrajería.

Encuéntrenla en la página 43.

Ref. BC98

DIN
338

PMD



BRILLANTE



70 HRC



Broca DIN 338 con punta de metal duro para METALES MUY DUROS ó TEMPLADOS.

Broca de ALTA DUREZA para taladrado de METALES MUY DUROS ó TEMPLADOS en cerrajería.

Encuéntrenla en la página 43.

Ref. BC85

MD

TOL D1
h7TOL D2
h6

TiAlN

HARDOX
600ALTA
PRODUCCIÓN70
HRC

Broca de metal duro integral para METALES TEMPLADOS, hasta dureza 70 HRC.

Broca de MÁXIMA DUREZA para taladrado de METALES TEMPLADOS en cerrajería.

Encuéntrenla en la página 70.

**HERRAMIENTAS PARA CERRAJEROS
LA MAS AMPLIA GAMA DE HERRAMIENTAS PARA CERRAJERÍA**



Ref. BCC06

MD



Broca de sección cuadrada fabricada en metal duro integral para TALADRADO DE BOMBILLOS Y PITONES ANTI-DRILLING. LA BROCA Nº1 PARA TALADRADO DE CILINDROS DE ALTA DUREZA en cerrajería. Encuéntrenla en la página 70.

TIPO
C

MD



Fresas CERRAJERO, también conocidas como VAMPIRO, fabricadas en metal duro integral. Geometría semiesférica en longitudes totales de 60 mm a 150 mm. La fresa ideal para FRESADO DE CILINDROS, seleccione entre la amplia gama de dimensiones la mas adecuada para su aplicación. Encuéntrenla en la página 344.

TIPO
A/E

TIPO
C

MD

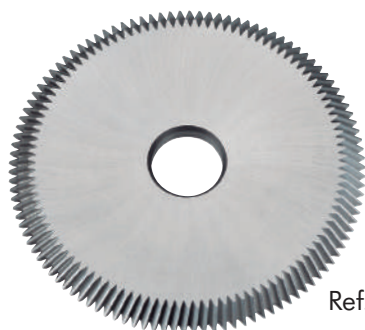

Fresas ROTATIVAS de metal duro forma A/E (Cilíndrica frontal) y forma C (semi esférica) La fresa ideal para FRESADO DE CILINDROS, seleccione entre la amplia gama de dimensiones la mas adecuada para su aplicación. Encuéntrenla en las páginas 331-332.

FRESAS PARA MÁQUINAS DUPLICADORAS DE LLAVES TIPO JMA
FRESAS DE SERRETA O BICONICAS

Ref. FLLFP4

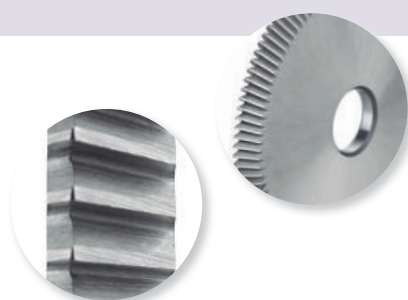

Ref. BM	Ref. JMA	TIPOS DE MÁQUINAS	MATERIAL	mm		mm	β°	Z	mm	FLL	€
				mm	mm						
FLLFP1 (FLL02)	FP1	OREGON	HSSV	25	10	10	100°	60	0,1		82,28
FLLFP2W	FP2W	VIRGINIA	MD	40	10	6	70°	70	0,1		323,59
FLLFP3 (FLL04)	FP3	KIS, SPRINT	HSSV	50	12	6	90°	80	0,15		100,13
FLLFP4 (FLL06)	FP4	KIS	HSSV	53	12,7	6,35	45/15°	72	0,6		103,28
FLLFP5	FP5	JMA	HSSV	57	12,7	5	90°	80	0,15		128,71
FLLFP6 (FLL09)	FP6	KIS, SPRINT	HSSV	60	12,7	5	84°	140	0,1		100,13
FLLFP11ECCO (FLL11)	FP11/ECCO-009	ECCO, ECCO-PLUS	HSSV	63	16	5	84°	80	1		95,79
FLLFP11W	FP11W	ECCO, ECCO-PLUS	MD	63	16	5	84°	80	1		292,94
FLLFP12	FP12	TUCSON	HSSV	63	16	5	80°	80	1,25		103,28
FLLFP12W	FP12W	TUCSON	MD	63	16	5	80°	80	1,25		316,31
FLLFP13	FP13	DALLAS	HSSV	63	16	5	84°	100	1		128,59
FLLCU14	CU14	ECCO, ECCO-PLUS	HSSV	63	16	5	80°	80	1,25		126,02
FLLFP16 (FLL13)	FP16	PROCEDURE	HSSV	70	16	5,25	76°	100	1		128,59
FLLFP16W	FP16W	PROCEDURE	MD	70	16	5,25	76°	100	1		316,31
SLLP01	FP24 DAKOTA = P01	DAKOTA, ERREBI SARATOGA, NEVADA, DENVER, TITAN, VIENNA	HSSV	80	16	5	84°	110	1		78,98
SLLP01/120	FP24 DAKOTA=P01/120		HSSV	80	16	5	84°	120	1		80,48
FLLFP24 (FLL16)	FP24 ERREBI		HSSV	80	16	5	84°	110	1,25		78,98
FLLFP24W	FP24W ERREBI		MD	80	16	5	84°	110	1,25		292,94
FLL99	FP24		HSSV	80	16	5	84°	110	0		91,25



Ref. FLL99: Fresa de serreta 80x5x16 Z110 sin chafán lateral.

FRESAS PARA MÁQUINAS DUPLICADORAS DE LLAVES TIPO JMA
SIERRAS CIRCULARES DE CORTE LATERAL

Ref. FLLFP19



Fresas

Rosa

Ref. BM	Ref. JMA	TIPOS DE MÁQUINAS	MATERIAL	mm			Z	€	FLL
FLLFP7	FP7	ECCO BIT, DETROIT	HSSV	63	16	1,25	80	100,13	
FLLFP7W	FP7W	ECCO BIT, DETROIT	MD	63	16	1,25	80	255,51	
FLLFP8 (FLL19)	FP8	ECCO BIT, DETROIT	HSSV	63	16	1,4	80	71,42	
FLLFP17	FP17	TITAN BIT, SARATOGA, YAKARTA	HSSV	80	16	1,25	100	73,17	
FLLFP17W	FP17W	TITAN BIT, SARATOGA, YAKARTA	MD	80	16	1,25	100	268,44	
FLLFP18	FP18	ATLANTA, TOPEKA	HSSV	80	22	1,25	100	100,13	
FLLFP18W	FP18W	ATLANTA, TOPEKA	MD	80	22	1,25	100	268,44	
FLLFP19 (FLL21)	FP19	SARATOGA, YAKARTA, TITAN BIT, DAKOTA	HSSV	80	16	1,4	100	75,86	
FLLFP19W	FP19W	SARATOGA, YAKARTA, TITAN BIT, DAKOTA	MD	80	16	1,4	100	251,42	
FLLFP20 (FLL22)	FP20	ATLANTA, TOPEKA	HSSV	80	22	1,4	100	75,86	
FLLFP21 (FLL24)	FP21	ATLANTA, TOPEKA, DUPLEX, KANSAS	HSSV	80	22	1,5	100	77,96	
FLLFP21W	FP21W	ATLANTA, TOPEKA, DUPLEX, KANSAS	MD	80	22	1,5	100	273,69	

SIERRAS PARA LLAVES DE GORJAS

Ref. FLLFP22W

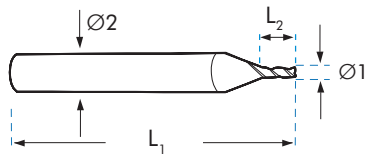

Ref. BM	Ref. JMA	TIPOS DE MÁQUINAS	MATERIAL	mm			Z	€	FLL
FLLFP9	FP9	ECCO BIT	HSSV	63	16	1	80	67,79	
FLLFP10	FP10	ECCO FORD, ECCO ABBLOY, PASADENA, NEBRASCA	HSSV	63	16	2,4	80	67,79	
FLLFP22	FP22	TITAN BIT, DAKOTA, SARATOGA	HSSV	80	16	1	100	72,31	
FLLFP22W	FP22W	TITAN BIT, DAKOTA, SARATOGA	MD	80	16	1	100	247,45	
FLLFP23	FP23	DUPLEX, ATLANTA, TOPEKA	HSSV	80	22	1	100	74,92	
FLLFP23W	FP23W	DUPLEX, ATLANTA, TOPEKA	MD	80	22	1	100	247,45	
FF68801416100CO	-	TITAN, DAKOTA, SARATOGA, YAKARTA	HSSCo	80	16	1,4	100	72,83	
FLLFP26 (FLL23)	FP26	G, SENNA, DAKOTA, SARATOGA, YAKARTA	HSSV	80	16	1,5	100	75,96	
FLLFP26W	FP26W	G, SENNA, DAKOTA, SARATOGA,	MD	80	16	1,5	100	250,93	

FRESAS PARA MÁQUINAS DUPLICADORAS DE LLAVES TIPO JMA
FRESAS PARA LLAVES DE REGATA

Ref. FLLF3



Fresas

Rosa

Ref. BM	Ref. JMA	TIPOS DE MÁQUINAS	MATERIAL	Ø ₁ mm	L ₁ mm	Ø ₂ mm	L ₂ mm	Z	€
FLLF3Z3	(FLL32) ≈ F3	ALBANY ARIZONA COLUMBIA DAKAR DAKAR EXPRESS DAY T-COL DAYTONA X CODE	HSSCo	1,5	45	6	3	3	35,70
FLLF3	(FLL44) F3		HSSCo	1,5	45	6	3	2	33,41
FLLF3W	(FLL45) F3W		MD	1,5	45	6	3	2	108,62
FLLF33	(FLL53) F33		HSSCo	2	45	6	4	3	32,26
FLL11Z3	(FLL33) ≈ F11		HSSCo	2,5	45	6	5	3	32,26
FLLF11	(FLL48) F11		HSSCo	2,5	45	6	5	2	28,86
FLLF11W	(FLL49) F11W		MD	2,5	45	6	5	2	82,23
FLLF17	(FLL34) F17		HSSCo	3	45	6	6	3	32,26
FLLF8Z3	(FLL35) ≈ F8		HSSCo	4	45	6	6	3	37,55
FLLF8	(FLL46) F8		HSSCo	4	45	6	7	2	33,41
FLLF8W	(FLL47) F8W		MD	4	45	6	6	2	101,94
FLLF77	(FLL36) -		HSSCo	5	45	6	7	3	37,55
FLLF78	(FLL37) -		HSSCo	6	45	6	8	3	37,55
FLLF78W	(FLL54) -		MD	6	45	6	8	3	82,23
FLLF78WZ4	(FLL55) -		MD	6	45	6	8	4	82,23

FLL

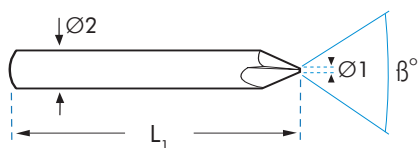
FRESAS DE PUNTEAR UNIVERSALES PARA MAQUINAS TIPO JMA Y SILCA

Ref. FLLF1



Ref. BM	Ref. JMA	TIPOS DE MÁQUINAS	MATERIAL	β°	Ø ₁ mm	L ₁ mm	Ø ₂ mm	Z	€
FLLF82	-	ALBANY ARIZONA CAPRI COLUMBIA DAKAR DAKAR EXPRESS DAY T-COL DAYTONA X CODE	HSSCo	82°	0,9	45	6	2	21,99
FLLF1	(FLL43) F1		HSSCo	90°	0,8	45	6	2	21,99
FLLF1W	(FLL42) F1W		MD	90°	0,8	45	6	2	68,12
FLLF5	(FLL52) F5		HSSCo	90°	0,9	45	6	2	21,99
FLLF5W	(FLL42) F5W		MD	90°	0,9	45	6	2	68,12
FLLF95	-		HSSCo	95°	0,9	45	6	2	21,99
FLLF13	(FLL50) F13		HSSCo	100°	0,8	45	6	2	21,99
FLLF13W	(FLL51) F13W		MD	100°	0,8	45	6	2	63,74
FLLF105	-		HSSCo	105°	0,9	45	6	2	21,99

FLL

PALPADORES PARA MÁQUINAS DUPLICADORAS DE LLAVES TIPO JMA

PALPADORES

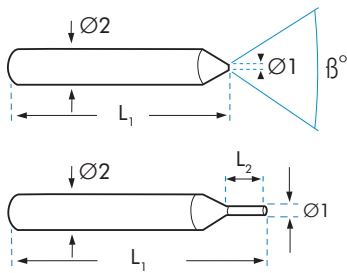

Ref. FLLP1



Ref. FLLP3



FLL

Ref. BM	Ref. JMA	TIPOS DE MÁQUINAS	MATERIAL	β°	\varnothing_1 mm	L ₁ mm	\varnothing_2 mm	L ₂ mm	€
FLLP1	(PLL38) P1	ALBANY ARIZONA CAPRI COLUMBIA DAKAR DAKAR EXPRESS DAY T-COL DAYTONA X CODE	HSSV	90°	0,8	45	6	-	17,90
FLLP3	(PLL32) P3		HSSV	-	1,5	45	6	4	31,67
FLLP5	P5		HSSV	90°	0,9	45	6	-	17,90
FLLP8	(PLL35) P8		HSSV	-	4	45	6	7	31,67
FLLP11	(PLL33) P11		HSSV	-	2,5	45	6	4	31,67
FLLP13	(PLL50) P13		HSSV	100°	0,8	45	6	-	17,90
FLLP17	(PLL34) P17		HSSV	-	3	45	6	6	31,67
FLLP52	(PLL52) -		HSSV	90°	0,9	45	6	-	17,90
FLLP77	(PLL36) -		HSSV	-	5	45	6	7	31,67
FLLP78	(PLL37) -		HSSV	-	6	45	6	8	31,67

FRESAS KEY LINE

Ref. BM	Ref. JMA	TIPOS DE MÁQUINAS	MATERIAL	β°	\varnothing_1 mm	L ₁ mm	\varnothing_2 mm	L ₂ mm	€
V001	-	KEY LINE	MD	90°	0,4	32	4	-	125,24
V003	-		MD	-	2,5	32	4	5	125,24
V004	-		MD	82°	0,5	32	4	-	125,24
V007	-		MD	100°	0,4	32	4	-	125,24
V012	-		MD	-	1,5	32	4	4	154,00

FRESAS PARA MÁQUINAS DUPLICADORAS DE LLAVES TIPO SILCA

FRESAS DE SERRETA O BICÓNICAS

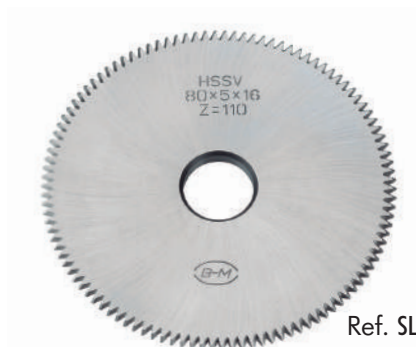

Ref. SLLP01

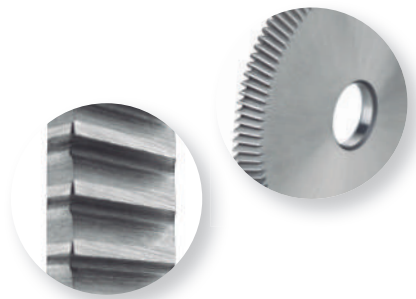

SLL

Ref. BM	Ref. SILCA	TIPOS DE MÁQUINAS	MATERIAL					Z		€
				mm	mm	mm	β°		mm	
SLL01F	O1F	FUTURA PRO	MD	60,4	9,52	3,05	40	110	0	138,33
SLLU01	U01	UNOCODE/ULTRACODE	HSSV	60,4	9,52	5,25	80	72	0,5	111,11
SLLU01W	U01W	UNOCODE/ULTRACODE	MD	60,4	9,52	5,25	80	72	0,5	355,00
SLLP21	P21	SILCA DELTA	HSSV	60,4	9,52	5,25	84	72	0,5	100,22
SLLP01	P01	BRAVO / POKER / REKORD / BRAVO SUPER / SUPER MASTER	HSSV	80	16	5	84	110	1	78,98
SLLP01/120	P01/120		HSSV	80	16	5	84	120	1	80,48
SLLP01W	P01W		MD	80	16	5	84	110	1	292,94

SIERRAS CIRCULARES DE CORTE LATERAL



Ref. SLLSG2



SLL

Ref. BM	Ref. SILCA	TIPOS DE MÁQUINAS	MATERIAL				Z	€
				mm	mm	mm		
SLLY2KW	Y2KW	DELTA	MD	63	16	1,35	80	268,44
SLLSG19	SG19	DELTA	HSSV	64,6	9,52	1,5	40	75,86
SLLSG19W	SG19W	DELTA	MD	64,6	9,52	1,5	40	255,51
SLLSG18	SG18	DELTA	HSSV	64,6	9,52	2,4	40	75,86
SLLSG18W	SG18W	DELTA	MD	64,6	9,52	2,4	40	255,51
SLLSG6	SG6	LANCER	HSSV	80	22	1,3	100	77,96
SLLSG6W	SG6W	LANCER	MD	80	22	1,3	100	268,44
SLLSG2	SG2	TARGA/TECH3/TECNICA	HSSV	80	22	1,5	100	77,96
SLLSG2W	SG2W	TARGA/TECH3/TECNICA	MD	80	22	1,5	100	268,44
SLLFSC4-CAW	FSCL4-CAW	DELTA	MD	80	22	1,8	100	279,06

FRESAS PARA MÁQUINAS DUPLICADORAS DE LLAVES TIPO SILCA
SIERRAS PARA LLAVES DE GORJAS

Ref. SLLSG7W

Ref. BM	Ref. SILCA	TIPOS DE MÁQUINAS	MATERIAL	mm			Z	SLL	€
SLLSG14W	SG14W	DELTA	MD	60,4	9,52	1,14	80	214,67	
SLLGB1	GB1	ULTRACODE / UNOCODE	HSSV	60,4	9,52	1,7	66	78,75	
SLL05	05	UNOCODE/ULTRACODE	HSSV	60,4	9,52	1,8	68	78,75	
SLL05W	05W	UNOCODE/ULTRACODE	MD	60,4	9,52	1,8	68	225,29	
SLLCU-15C	CU-15C	OPERA /TARGA	MD	63	16	1,5	80	293,45	
SLLSG17	SG17	DELTA	HSSV	64,6	9,52	1,8	70	78,75	
SLLSG17W	SG17W	DELTA	MD	64,6	9,52	1,8	70	247,45	
SLLSG13	SG13	UNOCODE / DELTA	HSSV	64,6	9,52	2	70	78,75	
SLLSG13W	SG13W	UNOCODE / DELTA	MD	64,6	9,52	2	70	293,45	
SLL06	06	UNOCODE/ULTRACODE	HSSV	64,6	9,52	2,4	70	78,75	
SLL06W	06W	UNOCODE/ULTRACODE	MD	64,6	9,52	2,4	70	239,27	
SLLSG3	SG3	OPERA /TARGA/TECH3	HSSV	80	22	1	100	74,92	
SLLSG3W	SG3W	OPERA /TARGA/TECH3	MD	80	22	1	100	247,45	
SLLSG4	SG4	OPERA /TARGA/TECH3	HSSV	80	22	1,25	100	74,92	
SLLSG4W	SG4W	OPERA /TARGA/TECH3	MD	80	22	1,25	100	247,45	
SLLSG5	SG5	LANCER	HSSV	80	22	1,3	100	74,92	
SLLSG5W	SG5W	LANCER	MD	80	22	1,3	100	247,45	
SLLSG7	SG7	OPERA / TARGA	HSSV	80	22	1,4	100	74,92	
SLLSG7M35	SG7M35	OPERA / TARGA	HSSCo	80	22	1,4	100	95,92	
SLLSG7W	SG7W	LANCER	MD	80	22	1,4	100	247,45	
SLLSG1	SG1	OPERA /TARGA/TECH3	HSSV	80	22	1,5	100	74,92	
SLLSG1W	SG1W	OPERA /TARGA/TECH3	MD	80	22	1,5	100	247,45	
SLLSG8	SG8	TECH3 / TECHNICA	HSSV	80	22	1,75	100	74,92	
SLLSG10	SG10	LANCER	HSSV	80	22	2	100	74,92	
SLLSG10W	SG10W	LANCER/ OPERA /TARGA	MD	80	22	2	100	257,95	
SLLSG11	SG11	SILCA GT40	HSSV	80	22	2,3	100	74,92	
SLLSG12	SG12	TARGA/TECH3/TECHNICA/OPERA	HSSV	80	22	2,5	100	74,92	
SLLSG58400	SG58400	DELTA	MD	80	22	4	100	236,95	
SLLPL1	PL1	PRIMA LASER	HSSV	100	22	1	100	129,27	
SLLPL1W	PL1W	PRIMA LASER	MD	100	22	1	100	331,66	
SLLPL1,25	PL1,25	PRIMA LASER	HSSV	100	22	1,25	100	129,27	
SLLPL1,25W	PL1,25W	PRIMA LASER	MD	100	22	1,25	100	316,28	
SLLPL1,5	PL1,5	PRIMA LASER	HSSV	100	22	1,5	100	129,27	
SLLPL1,5W	PL1,5W	PRIMA LASER	MD	100	22	1,5	100	316,28	
SLLPL1,7W	PL1,7W	PRIMA LASER	MD	100	22	1,7	100	325,97	
SLLPL2	PL2.0	PRIMA LASER	HSSV	100	22	2	100	129,27	
SLLPL2W	PL2.0W	PRIMA LASER	MD	100	22	2	100	325,97	

FRESAS PARA MÁQUINAS DUPLICADORAS DE LLAVES TIPO SILCA

FRESAS DE PUNTEAR

MATRIX

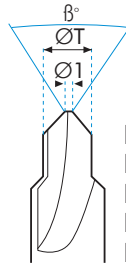
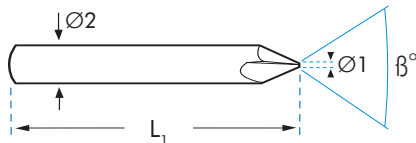
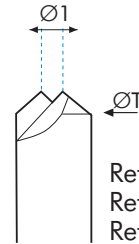

Ref. SLLF1W

 Ref. SLLF19-CAZ1
 Ref. SLLF19
 Ref. SLLF43
 Ref. SLLF21
 Ref. SLLF25

 Ref. SLLF12B
 Ref. SLLF15
 Ref. SLLF37



Ref. BM	Ref. SILCA	UNIV.	TIPOS DE MÁQUINAS	MATERIAL	β°	Ø1 mm	L1 mm	Ø2 mm	Z	SLL
										€
SLLF1Z1	F1	FLLF1	MATRIX	HSSV	90°	0,7	48	6	1	50,11
SLLF1	F1	FLLF1	MATRIX	HSSV	90°	0,7	48	6	2	50,11
SLLF1W	F1W	FLLF1W	MATRIX	MD	90°	0,7	48	6	1	89,58
SLLF4	F4	FLLF1	MATRIX	HSSV	90°	0,4	48	6	1	50,11
SLLF5	F5	FLLF5	MATRIX	HSSV	90°	0,9	48	6	1	50,11
SLLF6	F6	FLLF105	MATRIX	HSSV	106°	1	48	6	1	50,11
SLLF7	F7	FLLF82	MATRIX	HSSV	72°	0,8	48	6	2	50,13
SLLF12A	F12A	FLLF13	MATRIX	HSSV	100°	0,4	48	6	1	50,11
SLLF12B	F12B	FLLF1	MATRIX	HSSV	90°	8 x 1,8*	48	6	2	50,11
SLLF13	F13	FLLF1	MATRIX	HSSV	90°	0,77	48	6	1	50,11
SLLF14	F14	FLLF5	MATRIX	HSSV	90°	0,9	48	6	1	50,11
SLLF15	F15	FLLF1	MATRIX	HSSV	90°	8 x 0,8*	48	6	1	57,42
SLLF19	F19	FLLF1	MATRIX	HSSCo	90°	2,2 x 0,6*	48	6	1	50,13
SLLF19-CAZ1	F19-CA	FLLF1W	MATRIX	MD	90°	2,2 x 0,6*	48	6	1	89,58
SLLF20	F20	FLLF1	MATRIX	HSSV	90°	0,45	48	6	2	50,11
SLLF21	F21	FLLF82	MATRIX	HSSCo	85°	3,2 x 0,8*	48	6	1	57,42
SLLF23	F23	FLLF1	MATRIX	HSSV	90°	1,5	48	6	2	57,42
SLLF24	F24	FLLF13	MATRIX	HSSV	100°	1,3	48	6	1	50,11
SLLF25	F25	FLLF1	MATRIX	HSSV	90°	3,5 x 0,65*	48	6	1	50,11
SLLF26	F26	FLLF82	MATRIX	HSSV	82°	0,8	48	6	1	50,11
SLLF27-CA	F27-CA	-	MATRIX	MD	60°	2,4 x 1,9*	48	6	1	119,67
SLLF28	F28	-	MATRIX	HSSV	76°	0,76	48	6	1	50,11
SLLF29	F29	-	MATRIX	HSSV	76°	1,9 x 0,76*	48	6	1	50,11
SLLF34	F34	-	MATRIX	HSSV	50°	1,5	48	6	1	50,11
SLLF34-CAZ1	F34-CA	-	MATRIX	MD	50°	1,5	48	6	1	89,58
SLLF37	F37	FLLF1	MATRIX	HSSV	90°	6 x 2,1*	48	6	2	57,42
SLLF39	F39	FLLF1	MATRIX	HSSV	90°	0,6	48	6	2	60,86
SLLF42	F42	FLLF13	MATRIX	HSSV	100°	0,7	48	6	1	50,11
SLLF43	F43	FLLF1	MATRIX	HSSCo	90°	1	48	6	1	50,11
SLLF45	F45	-	MATRIX	HSSV	130°	0,56	48	6	1	50,13
SLLF46	F46	FLLF13	MATRIX	HSSV	100°	0,65	48	6	1	50,13
SLLF49	F49	FLLF95	MATRIX	HSSV	95°	0,8	48	6	1	57,42
SLLF50	F50	FLLF13	MATRIX	HSSV	100°	0,5	48	6	1	57,42
SLLF52-CA	F52-CA	-	MATRIX	MD	54°	0,86	48	6	2	50,11
SLLF59	F59	FLLF1	MATRIX	HSSV	90°	0,8	48	6	2	50,11
SLL01D	01D	-	FUTURA PRO	MD	90°	0,4	30	6	2	56,27
SLL02D	02D	-	FUTURA PRO	MD	100°	0,4	30	6	2	56,27

* Ø_T x Ø₁

FRESAS PARA MÁQUINAS DUPLICADORAS DE LLAVES TIPO SILCA

FRESAS PARA LLAVES DE REGATA

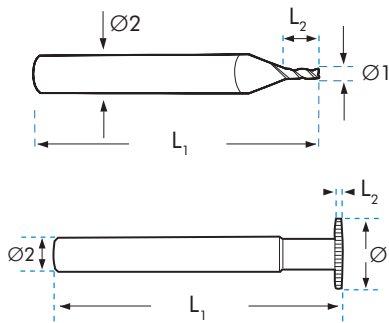
MATRIX



Ref. SLLF3



*Ref.SLLF62W

Ref. BM	Ref. SILCA	TIPOS DE MÁQUINAS	MATERIAL	Ø1 mm	L1 mm	Ø2 mm	L2 mm	Z	€	SLL
SLLF3	F3	MATRIX	HSSV	1,5	48	6	2	3	50,11	
SLLF8	F8	MATRIX	HSSV	4	48	6	13	3	50,11	
SLLF11	F11	MATRIX	HSSV	2,5	48	6	7	3	50,11	
SLLF22	F22	MATRIX	HSSV	2,5	42	6	6	3	50,11	
SLLF30	F30	MATRIX	HSSV	3	48	6	6	3	50,11	
SLLF30Z2	F30	MATRIX	HSSV	3	48	6	6	2	58,89	
SLLF44	F44	MATRIX	HSSV	2	40	6	6	3	50,11	
SLLF62W*	F62W	MATRIX	MD	11,8	48	6	1	20	159,97	
SLL01L	O1L	FUTURA PRO	MD	2,5	30	6	3	3	56,27	
SLL02L	O2L	FUTURA PRO	MD	2	30	6	3	3	56,27	

FRESAS PARA LLAVES DE REGATA

QUATTROCODE /TRIAX-E

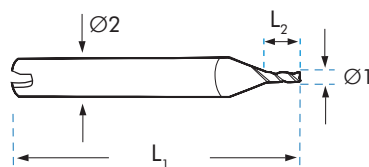

Ref. SLLW133



Ref. BM	Ref. SILCA	TIPOS DE MÁQUINAS	MATERIAL	Ø1 mm	L1 mm	Ø2 mm	L2 mm	Z	€	SLL
SLLW101	W101	QUATTROCODE /TRIAX-E	MD	2,5	40	6	6	3	114,30	
SLLW114	W114	QUATTROCODE /TRIAX-E	MD	2	40	6	6	3	114,32	
SLLW117	W117	QUATTROCODE /TRIAX-E	MD	5	48	6	R1	4	92,78	
SLLW129	W129	QUATTROCODE /TRIAX-E	MD	3	40	6	6	3	114,30	
SLLW131	W131	QUATTROCODE /TRIAX-E	MD	6	40	6	5	3	84,38	
SLLW133	W133	QUATTROCODE /TRIAX-E	MD	1,5	40	6	3	3	124,83	
SLLW134	W134	QUATTROCODE /TRIAX-E	MD	4	40	6	7	3	114,32	
SLLW219	W219	QUATTROCODE /TRIAX-E	MD	1,2	40	6	2	3	114,30	
SLLW235	W235	QUATTROCODE /TRIAX-E	MD	1,1	40	6	2	3	114,27	
SLLW268	W268	QUATTROCODE /TRIAX-E	MD	1,5	40	6	6	2	114,39	

FRESAS PARA MÁQUINAS DUPLICADORAS DE LLAVES TIPO SILCA

FRESAS DE PUNTEAR

QUATTROCODE / TRIAX-E

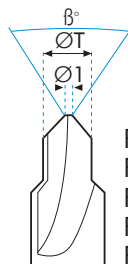
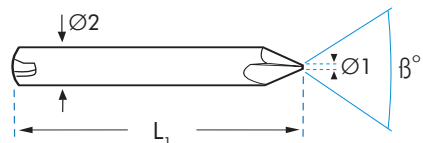
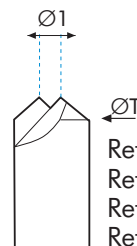

Ref. SLLW103

 Ref. SLLW115
 Ref. SLLW128
 Ref. SLLW135
 Ref. SLLW145
 Ref. SLLW210

 Ref. SLLW111
 Ref. SLLW126
 Ref. SLLW127
 Ref. SLLW139



Ref. BM	Ref. SILCA	TIPOS DE MÁQUINAS	MATERIAL	β°	\varnothing_1 mm	L1 mm	\varnothing_2 mm	Z	SLL	€
SLLW102	W102	QUATTROCODE / TRIAX-E	MD	106°	1	40	6	2		80,23
SLLW103	W103/W299	QUATTROCODE / TRIAX-E	MD	90°	0,8	40	6	2		80,23
SLLW104	W104	QUATTROCODE / TRIAX-E	MD	90°	1,2	40	6	2		80,23
SLLW105	W105	QUATTROCODE / TRIAX-E	MD	90°	0,7	40	6	2		80,23
SLLW106	W106	QUATTROCODE / TRIAX-E	MD	90°	0,6	40	6	2		80,23
SLLW107	W107	QUATTROCODE / TRIAX-E	MD	90°	0,9	40	6	2		80,23
SLLW108	W108	QUATTROCODE / TRIAX-E	MD	82°	0,9	40	6	2		80,23
SLLW109	W109	QUATTROCODE / TRIAX-E	MD	110°	0,4	40	6	2		80,23
SLLW110	W110	QUATTROCODE / TRIAX-E	MD	100°	0,6	40	6	2		80,23
SLLW111	W111	QUATTROCODE / TRIAX-E	MD	96°	8x2,75*	40	6	2		90,12
SLLW112	W112	QUATTROCODE / TRIAX-E	MD	60°/0°	1,5	40	6	2		80,75
SLLW113	W113	QUATTROCODE / TRIAX-E	MD	100°	0,76	40	6	2		80,23
SLLW115	W115	QUATTROCODE / TRIAX-E	MD	54°	4x0,86*	40	6	1		107,55
SLLW116	W116	QUATTROCODE / TRIAX-E	MD	90°	1	40	6	2		80,23
SLLW118	W118	QUATTROCODE / TRIAX-E	MD	120°	0,6	40	6	2		80,23
SLLW119	W119	QUATTROCODE / TRIAX-E	MD	85°	0,3	40	6	2		80,23
SLLW121	W121	QUATTROCODE / TRIAX-E	MD	86°	0,05	48	6	3		111,63
SLLW122	W122	QUATTROCODE / TRIAX-E	MD	90°	0,55	40	6	2		96,27
SLLW123	W123	QUATTROCODE / TRIAX-E	MD	76°	0,9	40	6	2		80,23
SLLW124	W124	QUATTROCODE / TRIAX-E	MD	90°	8x0,8*	48	6	3		153,78
SLLW126	W126	QUATTROCODE / TRIAX-E	MD	80°	3,3	48	6	2		96,27
SLLW127	W127	QUATTROCODE / TRIAX-E	MD	80°	2,1	48	6	2		96,27
SLLW128	W128	QUATTROCODE / TRIAX-E	MD	90°	4x0,55*	48	6	1		107,55
SLLW130	W130	QUATTROCODE / TRIAX-E	MD	90°	1,4	40	6	2		108,00
SLLW132	W132	QUATTROCODE / TRIAX-E	MD	60°	2	40	6	1		107,55
SLLW135	W135	QUATTROCODE / TRIAX-E	MD	90°	4x0,55*	40	6	2		107,48
SLLW136	W136	QUATTROCODE / TRIAX-E	MD	76°	2,23	40	6	1		107,55
SLLW138	W138	QUATTROCODE / TRIAX-E	MD	90°	4x0,7*	48	6	2		80,23
SLLW139	W139	QUATTROCODE / TRIAX-E	MD	60°/50°	0,9	40	6	2		119,67
SLLW142	W142	QUATTROCODE / TRIAX-E	MD	100°	1,2	40	6	2		80,23
SLLW145	W145	QUATTROCODE / TRIAX-E	MD	90°	3,2x0,8*	48	6	2		107,48
SLLW210	W210	QUATTROCODE / TRIAX-E	MD	90°	5x1,05*	40	6	3		160,98
SLLW213	W213	QUATTROCODE / TRIAX-E	MD	90°	0,95*	40	6	2		121,13
SLLW221	W221	QUATTROCODE / TRIAX-E	MD	90°	0,5	40	6	2		108,00
SLLW225	W225	QUATTROCODE / TRIAX-E	MD	90°	1	40	6	2		108,00
SLLW238	W238	QUATTROCODE / TRIAX-E	MD	90°	0,8	40	6	2		80,23
SLLW261	W261	QUATTROCODE / TRIAX-E	MD	1,1	3x1,5*	48	6	2		121,13
SLLW255	W255	QUATTROCODE / TRIAX-E	MD	90°	4x0,8*	48	6	2		108,00
SLLW293	W293	QUATTROCODE / TRIAX-E	MD	90°	0,85	40	6	2		108,00
SLLW299	W299	QUATTROCODE / TRIAX-E	MD	90°	3x0,80	40	6	2		80,80

* $\varnothing_T \times \varnothing_1$

FRESAS PARA MÁQUINAS DUPLICADORAS DE LLAVES TIPO SILCA

FRESAS DE PUNTEAR

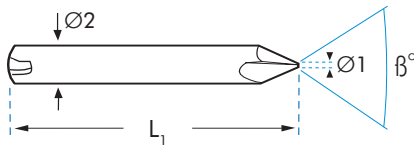
QUATTROCODE /TRIAX-E



Ref. SLLW103Z1

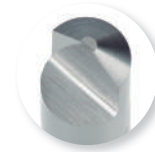

Ref. BM	Ref. SILCA	TIPOS DE MÁQUINAS	MATERIAL	β°	\varnothing_1 mm	L1 mm	\varnothing_2 mm	Z	€	SLL
SLLW102Z1	W102 Z1	QUATTROCODE /TRIAX-E	MD	106°	1	40	6	2	80,75	
SLLW103Z1	W103 Z1	QUATTROCODE /TRIAX-E	MD	90°	0,8	40	6	2	80,75	
SLLW104Z1	W104 Z1	QUATTROCODE /TRIAX-E	MD	90°	1,2	40	6	2	80,75	
SLLW105Z1	W105 Z1	QUATTROCODE /TRIAX-E	MD	90°	0,7	40	6	2	80,75	
SLLW106Z1	W106 Z1	QUATTROCODE /TRIAX-E	MD	90°	0,6	40	6	2	80,75	
SLLW107Z1	W107 Z1	QUATTROCODE /TRIAX-E	MD	90°	0,9	40	6	2	80,75	
SLLW108Z1	W108 Z1	QUATTROCODE /TRIAX-E	MD	82°	0,9	40	6	2	80,75	
SLLW109Z1	W109 Z1	QUATTROCODE /TRIAX-E	MD	110°	0,4	40	6	2	80,75	
SLLW113Z1	W113 Z1	QUATTROCODE /TRIAX-E	MD	100°	0,76	40	6	2	80,75	
SLLW116Z1	W116 Z1	QUATTROCODE /TRIAX-E	MD	90°	1	40	6	2	80,75	
SLLW118Z1	W118 Z1	QUATTROCODE /TRIAX-E	MD	120°	0,6	40	6	2	80,75	
SLLW119Z1	W119 Z1	QUATTROCODE /TRIAX-E	MD	85°	0,3	40	6	2	80,75	
SLLW122Z1	W122 Z1	QUATTROCODE /TRIAX-E	MD	90°	0,55	40	6	2	80,75	
SLLW123Z1	W123 Z1	QUATTROCODE /TRIAX-E	MD	76°	0,9	40	6	2	80,75	
SLLW146Z1	W146 Z1	QUATTROCODE /TRIAX-E	MD	90°	0,25	40	6	1	80,75	

FRESAS DE PUNTEAR

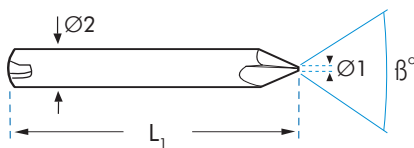

Ref. SLLH103

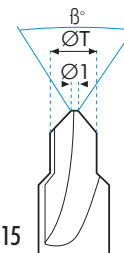

Ref. SLLH115

Ref. SLLH111
Ref. SLLH126
Ref. SLLH127

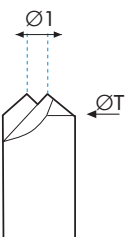

Ref. BM	Ref. SILCA	UNIV.	TIPOS DE MÁQUINAS	MATERIAL	β°	\varnothing_1 mm	L1 mm	\varnothing_2 mm	Z	€	SLL
SLLH103	H103	FLLF1	QUATTROCODE /TRIAX-E	HSSV	90°	0,8	40	6	2	59,19	
SLLH104	H104	FLLF1	QUATTROCODE /TRIAX-E	HSSV	90°	1,2	40	6	2	52,88	
SLLH105	H105	FLLF1	QUATTROCODE /TRIAX-E	HSSV	90°	0,7	40	6	2	52,88	
SLLH106	H106	FLLF1	QUATTROCODE /TRIAX-E	HSSV	90°	0,6	40	6	2	50,11	
SLLH107	H107	FLLF1	QUATTROCODE /TRIAX-E	HSSV	90°	0,9	40	6	2	50,11	
SLLH108	H108	FLLF82	QUATTROCODE /TRIAX-E	HSSV	82°	0,9	40	6	2	50,11	
SLLH110	H110	FLLF13	QUATTROCODE /TRIAX-E	HSSV	100°	0,6	40	6	2	50,11	
SLLH111	H111	FLLF95	QUATTROCODE /TRIAX-E	HSSV	96°	6,4x2,75*	40	6	2	50,11	
SLLH112	H112	-	QUATTROCODE /TRIAX-E	HSSV	60°	1,5	40	6	2	50,11	
SLLH113	H113	FLLF13	QUATTROCODE /TRIAX-E	HSSV	100°	0,76	40	6	2	50,11	
SLLH115	H115	-	QUATTROCODE /TRIAX-E	HSSV	54°	4x0,86*	40	6	1	50,11	
SLLH116	H116	FLLF1	QUATTROCODE /TRIAX-E	HSSV	90°	1	40	6	2	66,14	
SLLH118	H118	-	QUATTROCODE /TRIAX-E	HSSV	120°	0,6	40	6	1	50,11	
SLLH119	H119	FLLF82	QUATTROCODE /TRIAX-E	HSSV	85°	0,3	40	6	2	50,11	
SLLH122	H122	FLLF1	QUATTROCODE /TRIAX-E	HSSV	90°	0,55	40	6	2	50,11	
SLLH126	H126	FLLF85	QUATTROCODE /TRIAX-E	HSSV	80°	3,3*	48	6	2	74,79	
SLLH127	H127	FLLF85	QUATTROCODE /TRIAX-E	HSSV	80°	2,1*	48	6	2	74,79	
SLLH128	H128	FLLF1	QUATTROCODE /TRIAX-E	HSSV	90°	0,75	48	6	2	50,11	

* $\varnothing_T \times \varnothing_1$

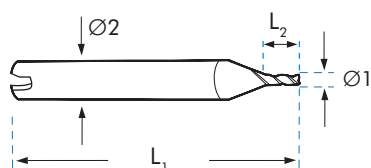
FRESAS PARA MÁQUINAS DUPLICADORAS DE LLAVES TIPO SILCA
FRESAS PARA LLAVES DE REGATA

Ref. SLLH101



Fresas

Rosa

Ref. BM	Ref. SILCA	TIPOS DE MÁQUINAS	MATERIAL	Ø ₁ mm	L ₁ mm	Ø ₂ mm	L ₂ mm	Z	SLL	€
SLLH101	H101	QUATTROCODE / TRIAX-E	HSSV	2,5	40	6	6	3		58,86
SLLH114	H114	QUATTROCODE / TRIAX-E	HSSV	2	40	6	6	3		50,11
SLLH117	H117	QUATTROCODE / TRIAX-E	HSSV	5	48	6	R1	4		60,80
SLLH129	H129	QUATTROCODE / TRIAX-E	HSSV	3	40	6	6	3		50,11
SLLH131	H131	QUATTROCODE / TRIAX-E	HSSV	6	40	6	5	3		66,14

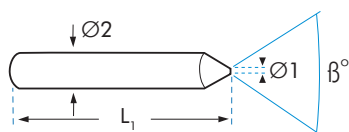
PALPADORES

Ref. SLLT1

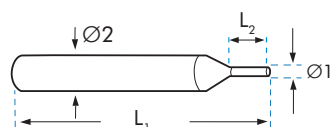

Ref. SLLT3



Ref. BM	Ref. SILCA	TIPOS DE MÁQUINAS	Ref. FRESA	MATERIAL	β°	Ø ₁ mm	L ₁ mm	Ø ₂ mm	L ₂ mm	Ø _T mm	SLL	€
SLLT1	T1	MATRIX	F1	HSSV	90°	0,7	48	6	-	-		34,99
SLLT2	T2	MATRIX	F2	HSSV	88°	1,6	48	6	-	-		39,41
SLLT3	T3	MATRIX	F3	HSSV	-	1,5	48	6	3	-		39,41
SLLT4	T4	MATRIX	F4	HSSV	90°	0,4	48	6	-	-		39,41
SLLT5	T5	MATRIX	F5	HSSV	90°	0,9	48	6	-	-		39,41
SLLT6	T6	MATRIX	F6	HSSV	106°	1	48	6	15	-		39,41
SLLT7	T7	MATRIX	F7	HSSV	72°	0,8	48	6	2	-		39,41
SLLT8	T8	MATRIX	F8	HSSV	-	4	48	6	12	-		39,41
SLLT11	T11	MATRIX	F11	HSSV	-	2,5	48	6	6	-		39,41
SLLT12A	T12A	MATRIX	F12A	HSSV	100°	0,4	48	6	-	-		39,41
SLLT12B	T12B	MATRIX	F12B	HSSV	90°	2,8	48	6	-	-		39,41
SLLT13	T13	MATRIX	F13	HSSV	90°	0,77	48	6	-	-		39,41
SLLT14	T14	MATRIX	F14	HSSV	90°	0,9	48	6	-	-		39,41
SLLT15	T15	MATRIX	F15	HSSV	90°	0,8	48	6	-	-		39,41
SLLT19	T19	MATRIX	F19	HSSV	90°	2,2 x 0,6*	48	6	-	-		39,41
SLLT20	T20	MATRIX	F20	HSSV	90°	0,45	48	6	-	-		39,41
SLLT21	T21	MATRIX	F21	HSSV	85°	3,2 x 0,8*	48	6	-	-		39,41
SLLT22	T22	MATRIX	F22	HSSV	-	2,5	42	6	6	-		39,41
SLLT23	T23	MATRIX	F23	HSSV	90°	1,5	48	6	5	-		39,41

FRESAS PARA MÁQUINAS DUPLICADORAS DE LLAVES TIPO SILCA

PALPADORES

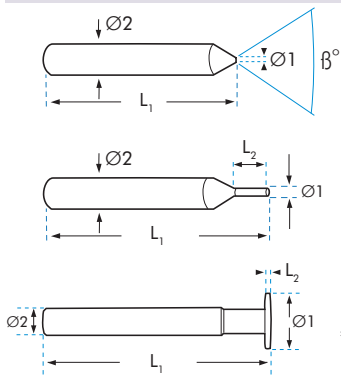

*Ref. SLLT62W



Ref. SLLT1



Ref. SLLT3



Fresas

Rosa

Ref. BM	Ref. SILCA	TIPOS DE MÁQUINAS	Ref. FRESA	MATERIAL	β°	\varnothing_1 mm	L1 mm	\varnothing_2 mm	L2 mm	\varnothing_T mm	€
SLLT24	T24	MATRIX	F24	HSSV	100°	1,3	48	6	-	-	39,41
SLLT25	T25	MATRIX	F25	HSSV	90°	3,5 x 0,65*	48	6	-	-	39,41
SLLT26	T26	MATRIX	F26	HSSV	82°	0,8	48	6	-	-	39,41
SLLT27	T27	MATRIX	F27	HSSV	60°	1,28	48	6	-	-	44,48
SLLT28	T28	MATRIX	F28	HSSV	76°	0,76	48	6	-	-	39,41
SLLT29	T29	MATRIX	F29	HSSV	76°	1,9	48	6	-	-	39,41
SLLT30	T30	MATRIX	F30	HSSV	-	3	48	6	10	-	39,41
SLLT30-45	T30-45	MATRIX		HSSV	-	3	45	6	10	-	39,41
SLLT33	T33	MATRIX	F33	HSSV	48°	1,4	48	6	-	-	58,76
SLLT34	T34	MATRIX	F34	HSSV	50°	1,5	48	6	-	-	39,41
SLLT37	T37	MATRIX	F37	HSSV	90°	2,1	48	6	-	-	39,41
SLLT39	T39	MATRIX	F39	HSSV	90°	0,6	48	6	-	-	39,41
SLLT40	T40	MATRIX	F40	HSSV	108°	0,4	48	6	-	-	39,41
SLLT42	T42	MATRIX	F42	HSSV	100°	0,7	48	6	-	-	39,41
SLLT43	T43	MATRIX	F43	HSSV	90°	1	48	6	-	-	39,41
SLLT44	T44	MATRIX	F44	HSSV	-	2	48	6	8	-	39,41
SLLT44-45	T44-45	MATRIX		HSSV	-	2	45	6	8	-	39,41
SLLT46	T46	MATRIX	F46	HSSV	100°	0,65	48	6	-	-	39,41
SLLT49	T49	MATRIX	F49	HSSV	95°	0,8	48	6	-	-	39,41
SLLT50	T50	MATRIX	F50	HSSV	100°	0,5	48	6	-	-	39,41
SLLT52	T52	MATRIX	F52	HSSV	54°	0,86	48	6	6	2	39,41
SLLT54	T54	MATRIX	F54	HSSV	-	4	40	6	6,5	-	50,11
SLLT55	T55	MATRIX	F55	HSSV	100°	1	48	6	4	-	39,41
SLLT59	T59	MATRIX	F59	HSSV	90°	0,8	48	6	-	-	39,41
SLLT62W*	T62W	MATRIX	F62W	MD	-	11,8	48	6	1	-	78,68
SLLT63	T63	MATRIX	F63	HSSV	78°	0,5	48	6	4	3	39,41
SLLT65	T65	MATRIX	F65	HSSV	90°	1,05	48	6	5	3	39,41
SLLT101	T101	MATRIX		HSSV	-	2,5	40	6	6	-	39,41
SLLT129	T129	MATRIX		HSSV	-	3	40	6	10	-	39,41
SLLU101	U101	QUATTROCODE		MD	-	1,2	48	6	3	-	50,11
SLLU101/H	U101/H	QUATTROCODE /TRIAX-E		MD	-	1,2	48	6	3	-	34,05
SLLU102/65	U102/65	QUATTROCODE /TRIAX-E		MD	30°	0,2	48	6	9	2,6	53,52
SLLU102TT	U102TT	QUATTROCODE /TRIAX-E		MD	30°	0,2	26	4	6	2	53,52
SLLU103	U103	QUATTROCODE /TRIAX-E		MD	-	1	48	6	3	-	50,11
SLLU103/H	U103/H	QUATTROCODE /TRIAX-E		MD	-	1	48	6	3	-	34,05
SLLU103-TT	U103-TT	QUATTROCODE /TRIAX-E		MD	-	1	21	4	3	-	50,11
SLLU103-TT/H	U103-TT/H	QUATTROCODE /TRIAX-E		MD	-	1	21	4	3	-	34,05
SLLU111	U111	SILCA VIPER		MD	-	1	40	6	2,2	-	50,11
SLLU111/H	U111/H	SILCA VIPER		MD	-	1	40	6	2,2	-	34,05
SLLB3304	B3304	KEYLINE BIANCHI 994 LASER		MD	-	1	33	6	6	-	50,13
SLLB3310	B3310	KEYLINE BIANCHI 994 LASER		MD	-	1	30	6	2,6	-	50,13
SLLB3310M2	B3310	KEYLINE BIANCHI 994 LASER		HSSV	-	1	30	6	2,6	-	37,13



SLL

FRESAS PARA MÁQUINAS DUPLICADORAS DE LLAVES TIPO FLORA, NOVACLAU, WALKIN

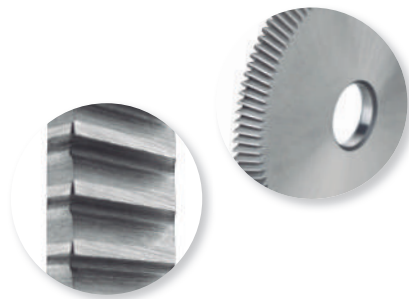
OTRAS FRESAS DE USO GENERAL





SERRETA Ó BICÓNICAS

Ref. BM	TIPOS DE MÁQUINAS	MATERIAL	mm			Z	FLL
			 mm	 mm	 mm		€
FLL01	FLORA	HSSV	23	10	5	36	88,41
FLL03	YALE	HSSV	40	8	5	80	95,93
FLL05	NOVACLAU	HSSV	52	16	5	110	113,26
FLL07	KIS	HSSV	53	12,7	6	80	126,02
FLL08	KIS	HSSV	55	12	6	80	126,02
FLL10	NOVACLAU	HSSV	61	12,7	6,5	140	128,31
FLL11	NOVACLAU	HSSV	62	16	5	80	125,81
FLL12	NOVACLAU	HSSV	63	16	5	140	125,81
FLL14	WALKIN	HSSV	70	15	6,5	150	133,20
FLL15	LINCE	HSSV	70	13	7	88	129,59



CORTE LATERAL

Ref. BM	TIPOS DE MÁQUINAS	MATERIAL	mm			Z	FLL
			 mm	 mm	 mm		€
FLL17	JMA-NOVACLAU-WALKIN	HSSV	35	12	3,15	50	66,11
FLL18	JMA-NOVACLAU-WALKIN	HSSV	63	15	1,40	80	80,84
FLL20	JMA-NOVACLAU-WALKIN	HSSV	70	16	1,40	100	99,88